

Gauge Valves and Instrumentation Manifolds

GV, GVH, GR Series

2-valve, 3-valve and 5-valve Manifold Series



Contents

Gauge Valves

GV Series, GVH Series and GR Series



C-04

Instrumentation Manifolds

2-valve Manifolds



C-09

3-valve Manifolds



C-12

5-valve Manifolds



C-14

C Integral Manifolds



C-18

Accessories

Manifold Bracket Supports

C-21

Kidney Flange / Eccentric Flange

C-21

Bleed Valves

C-22

Calibration Fittings

C-22

Gauge Valves

GV Series, GVH Series and GR Series

Features

- ⦿ Working pressure up to:
 - Stainless steel: GV, GR up to 6000 psig (414 bar)
 - GVH up to 10000 psig (690 bar)
- ⦿ GV Series and GVH Series working temperature:
 - PTFE packing: -65°F to 450°F (-54°C to 232°C)
 - Graphite packing: -65°F to 1200°F (-54°C to 649°C)
- ⦿ GR Series working temperature:
 - Acetal seat: -20°F to 250°F (-28°C to 121°C)
 - PEEK seat: -20°F to 400°F (-28°C to 204°C)
- ⦿ Non-rotating lower stem, ball tip and plug tip designs
- ⦿ Variety of materials for seat and packing
- ⦿ Safety back seating seals in fully open position
- ⦿ Rolled spindle operating threads
- ⦿ Lubricant for stem thread isolated from the media
- ⦿ Externally adjustable gland
- ⦿ Bonnet locking pin fitted as standard
- ⦿ Low torque operating T bar handle
- ⦿ Option for different colored handles
- ⦿ Steady and durable fastening of the handle by double lock-pins
- ⦿ Each GV/GR Series gauge valve leak tested with Nitrogen or compressed air at the maximum working pressure, each GVH Series gauge valve leak tested with water at 1.1 times the maximum working pressure



Standard Materials of Construction

Item	Component	Valve Body Material
		Material Grade/ASTM Specification
		316 SS
1	Handle	6061/B211
2	Set Screw	Stainless steel
3	Packing Bolt	304 SS/A479
4	Upper Stem	316 SS/A479
5	Lock Nut	Stainless steel
6	Bonnet	316 SS/A479
7	Gland	316 SS/A479
8	Packing	PTFE or graphite
9	Lock Pin	Stainless steel
10	Lower Stem	Hardened 316 SS/A479
11	Body	316 SS/A479 316 SS/A182
12	Seat	Acetal or PEEK
	Lubricant	Molybdenum disulfide-based

Ball Tip Design Valves (GV, GVH)

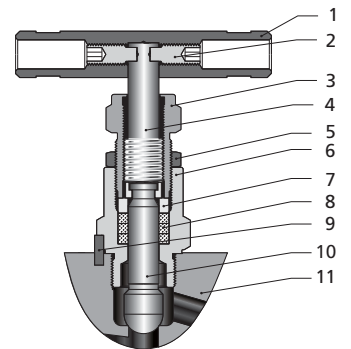

Plug Tip Design Valves (GR)

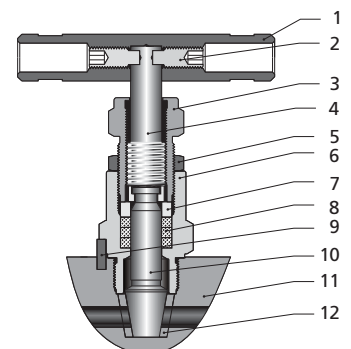

Process interface valves for sour gas service are available. Materials are selected in accordance with NACE MR0175/ISO 15156. Contact FITOK Group or our authorized distributors if you have any request.

Pressure vs. Temperature

GV Series Ball Tip Design Gauge Valves

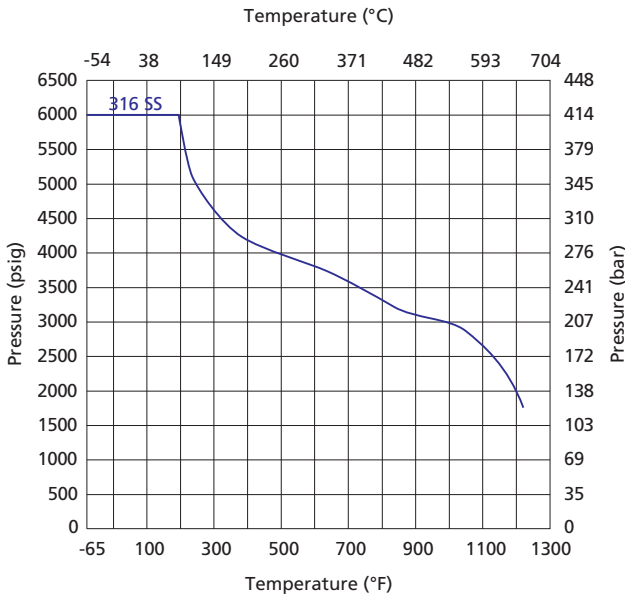

GVH Series Ball Tip Design Gauge Valves

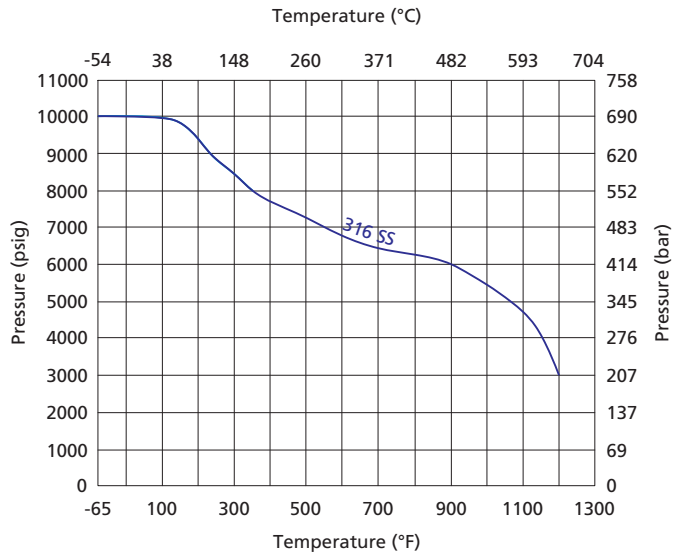

Based on graphite packing.

GR Series Plug Tip Design Gauge Valves

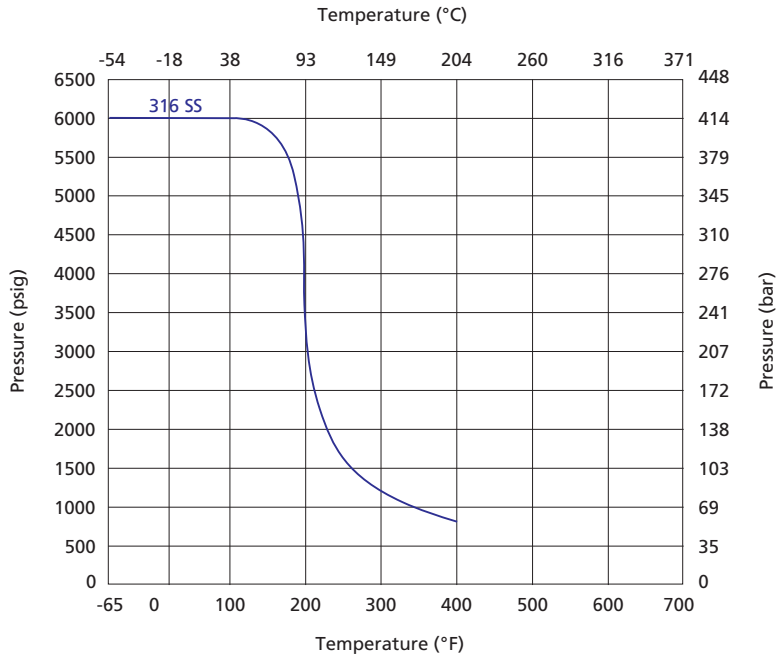

1. For manifolds of Acetal seat, the maximum medium temperature is 250°F (121°C), not recommended for temperature higher than 200°F (93°C) for water and steam application.
2. Based on PEEK seat and PTFE packing.

Types and Dimensions

Standard Type

Basic Ordering Number	Design	Inlet/Process	Outlet/Instrument	Test/Vent/Plug
GV □□-NS8-FNS8	Ball Tip	1/2 Male NPT	1/2 Female NPT	1/2 Female NPT
GVH □□-NS8-FNS8				
GR □□-NS8-FNS8	Plug Tip			
GV □□-NS12-FNS8	Ball Tip	3/4 Male NPT	1/2 Female NPT	1/2 Female NPT
GVH □□-NS12-FNS8				
GR □□-NS12-FNS8	Plug Tip			

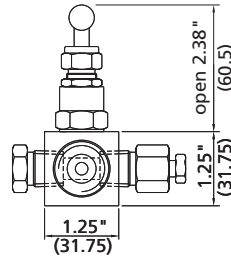
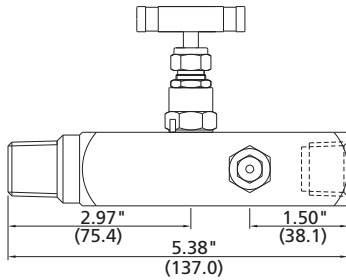
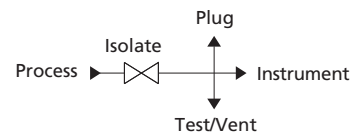

The dimensions shown are for GV series gauge valves. If you need the dimensions of GVH series, please contact FITOK Group.

Lagging Extension Body Type

Basic Ordering Number	Inlet/Process	Outlet/Instrument	Test/Vent/Plug
GV □□-NS8-FNS8-E	1/2 Male NPT	1/2 Female NPT	1/2 Female NPT
GVH □□-NS8-FNS8-E			
GR □□-NS8-FNS8-E			

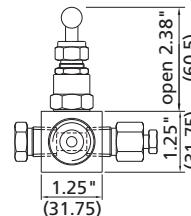
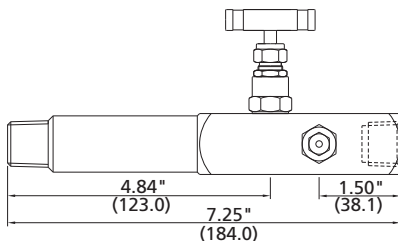
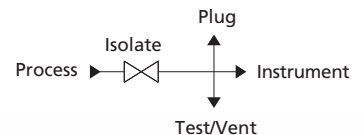

Lagging extension body is inserted through pipe insulation.

The dimensions shown are for GV series gauge valves. If you need the dimensions of GVH series, please contact FITOK Group.

Miniature Type

Basic Ordering Number	Inlet/Process	Outlet/Instrument	Vent
GV □□-NS8-FNS8-C	1/2 Male NPT	1/2 Female NPT	Vent stem
GVH □□-NS8-FNS8-C			
GR □□-NS8-FNS8-C			

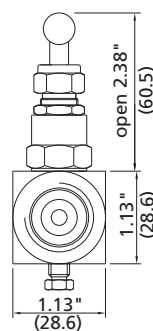
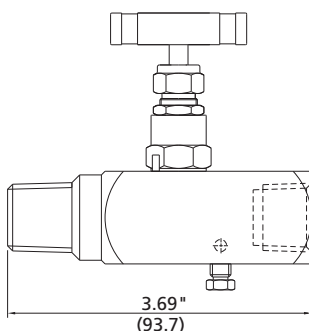
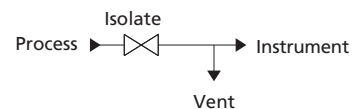

The dimensions shown are for GV series gauge valves. If you need the dimensions of GVH series, please contact FITOK Group.

Ordering Number Description

GRSS – NS8 – FNS8 – CPW – GR – SF2

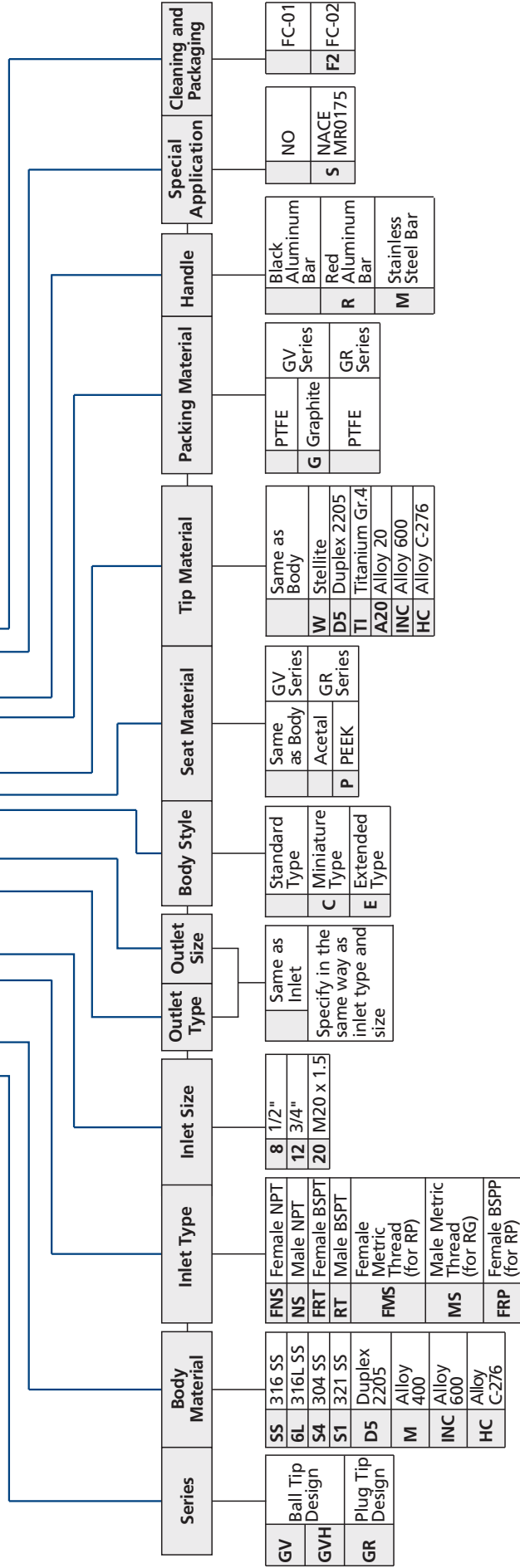

Note: "Ordering Number Description" is a reference to understand the combination rules of FITOK product part number. Not all combinations are available.

Cleaning and Packaging:

FC-01: Standard cleaning and packaging for general industrial procedures.

FC-02: Special cleaning and packaging for wetted system components to ensure compliance with product cleanliness requirement as stated in ASTM G93 Level C.

Instrumentation Manifolds

Features

- ⦿ Working pressure up to:
 - Stainless steel: 2D, 2R, 3D, 3R, 5D, 5R up to 6000 psig (414 bar)
 - 2DH, 2RH, 3DH, 3RH, 5DH, 5RH up to 10000 psig (690 bar)
 - Alloy C-276: 2D, 2R, 3D, 3R, 5D, 5R up to 6000 psig (414 bar)
- ⦿ Working temperature:
 - PTFE packing: -65°F to 450°F (-54°C to 232°C)
 - Graphite packing: -65°F to 1200°F (-54°C to 649°C)
- ⦿ Orifice: 0.157" (4.0 mm)
- ⦿ Two-piece stem design: Upper stem threads cold rolled and hardened lower stem for high strength and smooth operation
- ⦿ Upper stem thread lubricant isolated from system media
- ⦿ Linear instead of rotary motion of the rising, non-rotating stem minimizes packing abrasion and reduces the friction between the seat and the tip
- ⦿ Safety back seating seals in fully open position
- ⦿ Steady and durable fastening of the handle by double lock-pins
- ⦿ Each 2D/2R/3D/3R/5D/5R Series manifold leak tested with Nitrogen or compressed air at the maximum working pressure, each 2DH/2RH/3DH/3RH/5DH/5RH Series manifold leak tested with water at 1.1 times the maximum working pressure



Pressure vs. Temperature

2D, 2R, 3D, 3R, 5D, 5R Series

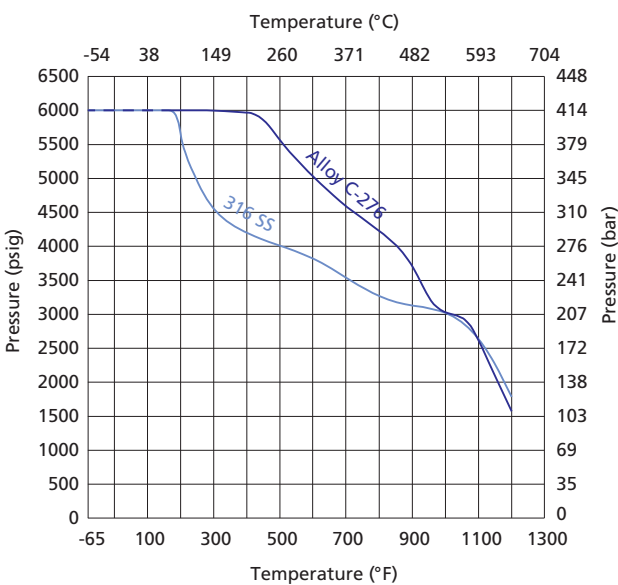

2DH, 2RH, 3DH, 3RH, 5DH, 5RH Series

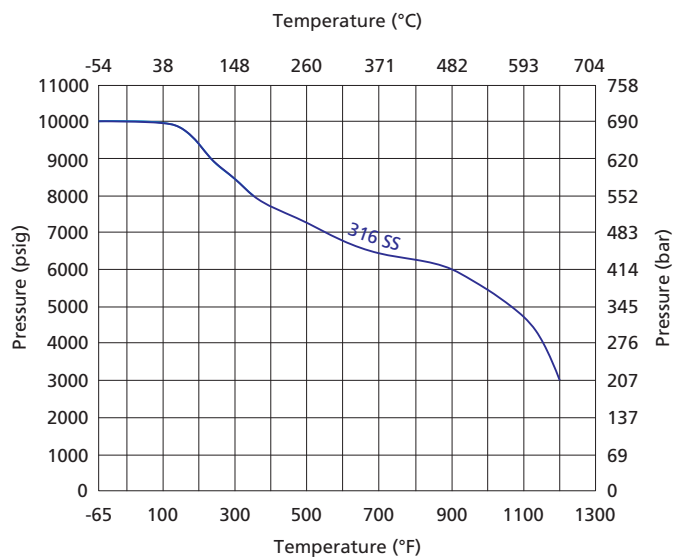

1. Based on graphite packing.
 2. Contact FITOK Group or our authorized distributors for curve graph of other materials.

Standard Materials of Construction

Item	Component	Valve Body Material	
		316 SS	Alloy C-276
Material Grade/ASTM Specification			
1	Handle	6061/B211	
2	Set Screw	Stainless steel	
3	Packing Bolt	304 SS/A479	
4	Upper Stem	316 SS/A479	
5	Lock Nut	Stainless steel	
6	Bonnet	316 SS/A479	Alloy C-276/B574
7	Gland	316 SS/A479	
8	Packing	PTFE or Graphite	
9	Lock Pin	Stainless steel	
10	Lower Stem	Hardened 316 SS/A479	Alloy C-276/B574
11	Body	316 SS/A479 316 SS/A182	Alloy C-276/B564
Lubricant		Molybdenum disulfide-based	

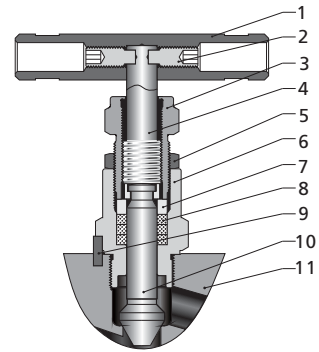

Handle colors indicate function:
 BLACK=Isolate/block
 RED=Test/vent
 GREEN=Equalize

Process interface valves for sour gas service are available. Materials are selected in accordance with NACE MR0175/ISO 15156. Contact FITOK Group or our authorized distributors if you have any request.

Design Standards

- Instrumentation manifolds are designed and manufactured in accordance with ASME B31.3 and MSS-SP-105. Flanges in compliance with MSS SP-99 or IEC 61518 are available.
- 2-valve manifold is used with pressure gauges or pressure transmitters.
- 3-valve and 5-valve manifolds are used with differential pressure transmitters.

Types and Dimensions

2-valve Manifolds

Consist of one block valve and one bleed valve

Basic Ordering Number	Inlet/Process	Outlet/Instrument	Test/Vent
2D□□-FNS8-A	1/2 Female NPT	Flange	1/4 Female NPT
2DH□□-FNS8-A			

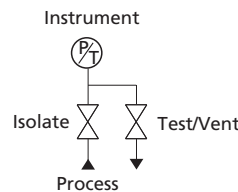
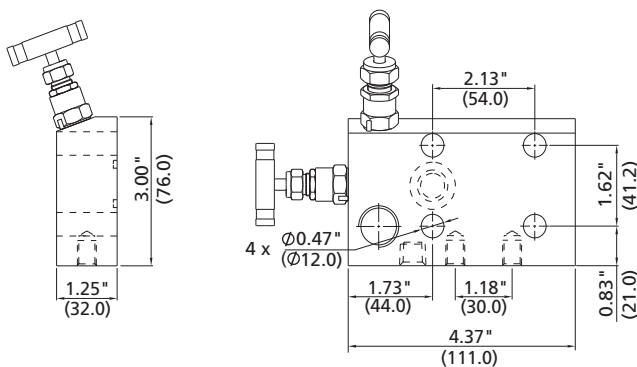

Notes: 1. Every manifold is supplied with one PTFE sealing ring for manifold-to-instrument and four 7/16" UNF x 1.75" high tensile bolts

2. Dimensions shown are for 2D Series manifolds. For dimensions of 2DH Series manifolds, please contact FITOK Group or our authorized distributors

C-10 Gauge Valves and Instrumentation Manifolds

Basic Ordering Number	Inlet/Process	Outlet/Instrument	Test/Vent
2D□□-FNS8-L	1/2 Female NPT	Flange	1/4 Female NPT

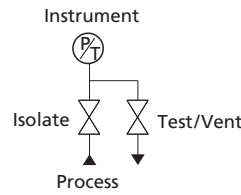
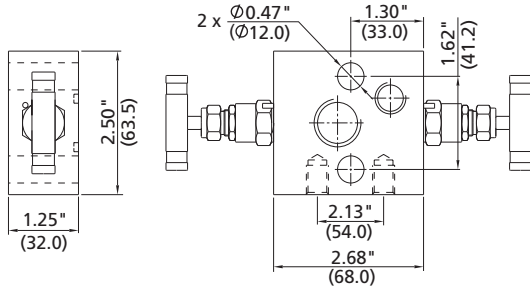

Every manifold is supplied with one PTFE sealing ring for manifold-to-instrument and two 7/16" UNF x 1.75" high tensile bolts.

Basic Ordering Number	Inlet/Process	Outlet/Instrument	Test/Vent
2D□□-FNS8-V	1/2 Female NPT	Flange	1/4 Female NPT

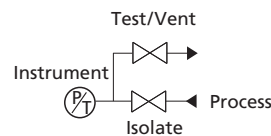
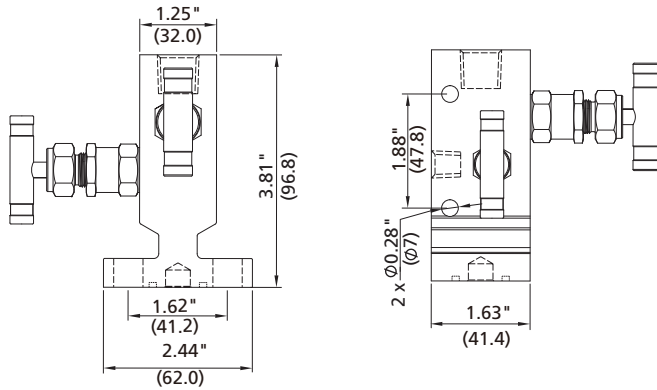

Every manifold is supplied with one PTFE sealing ring for manifold-to-instrument and two 7/16" UNF x 24 mm high tensile bolts.

Basic Ordering Number	Inlet/Process	Outlet/Instrument	Test/Vent
2R□□-FNS4-A	1/4 Female NPT	1/4 Female NPT	1/4 Female NPT
2RH□□-FNS4-A			

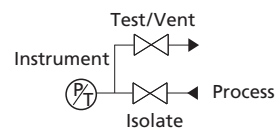
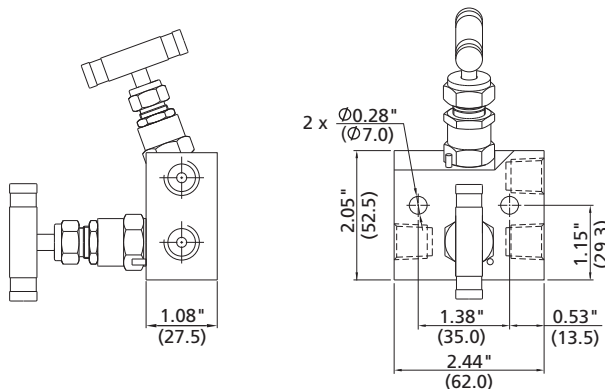

Dimensions shown are for 2R Series manifolds. For dimensions of 2RH Series manifolds, please contact FITOK Group or our authorized distributors.

FITOK

Basic Ordering Number	Inlet/Process	Outlet/Instrument	Test/Vent
2R □□ -FNS8-L	1/2 Female NPT	1/2 Female NPT	1/4 Female NPT

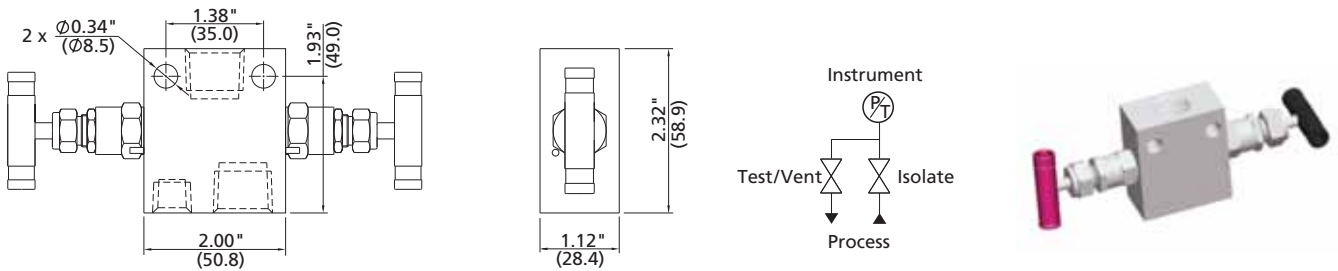

Basic Ordering Number	Inlet/Process	Outlet/Instrument	Test/Vent
2R □□ -FNS8-NS8-H	1/2 Female NPT	1/2 Male NPT	1/4 Female NPT
2RH □□ -FNS8-NS8-H			
2R □□ -NS8-H	1/2 Male NPT	1/2 Male NPT	1/4 Female NPT
2RH □□ -NS8-H			

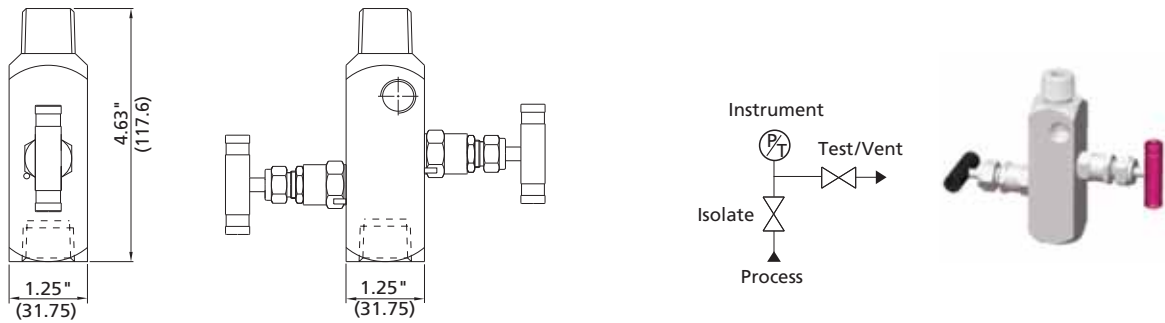

Dimensions shown are for 2R Series manifolds. For dimensions of 2RH Series manifolds, please contact FITOK Group or our authorized distributors.

Basic Ordering Number	Inlet/Process	Outlet/Instrument	Test/Vent
2R □□ -FNS8-V	1/2 Female NPT	1/2 Female NPT	1/4 Female NPT

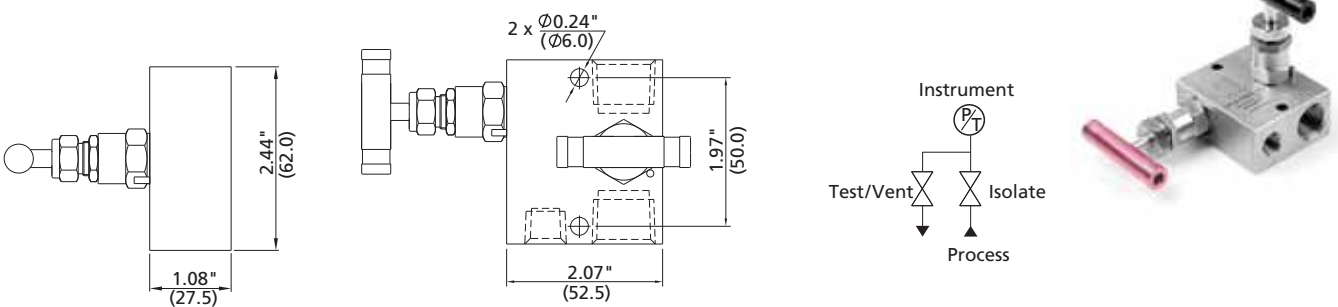

Manifolds

C-12 Gauge Valves and Instrumentation Manifolds

3-valve Manifolds

Consist of two block valves and one equalizer valve

Basic Ordering Number	Inlet/Process	Outlet/Instrument
3D □□ -FNS8-A	1/2 Female NPT	Flange
3DH □□ -FNS8-A		
3D □□ -FL8-A	1/2" FITOK	Flange

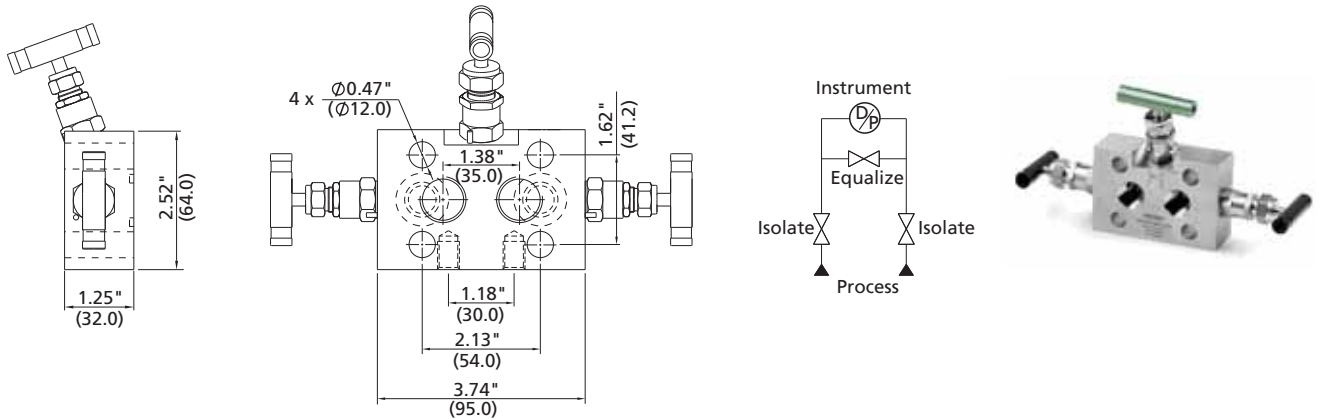

- Notes: 1. Every manifold is supplied with two PTFE sealing rings manifold-to-instrument and four 7/16" UNF x 1.75" high tensile bolts.
 2. FL8 connections are obtained by adding an extra CM tube fitting to the FNS8 connections.
 3. Dimensions shown are for 3D Series manifolds. For dimensions of 3DH Series manifolds, please contact FITOK Group or our authorized distributors.

Basic Ordering Number	Inlet/Process	Outlet/Instrument	Test/Vent
3D □□ -FNS8-L	1/2 Female NPT	Flange	Optional
3D □□ -FL8-L	1/2" FITOK	Flange	Optional

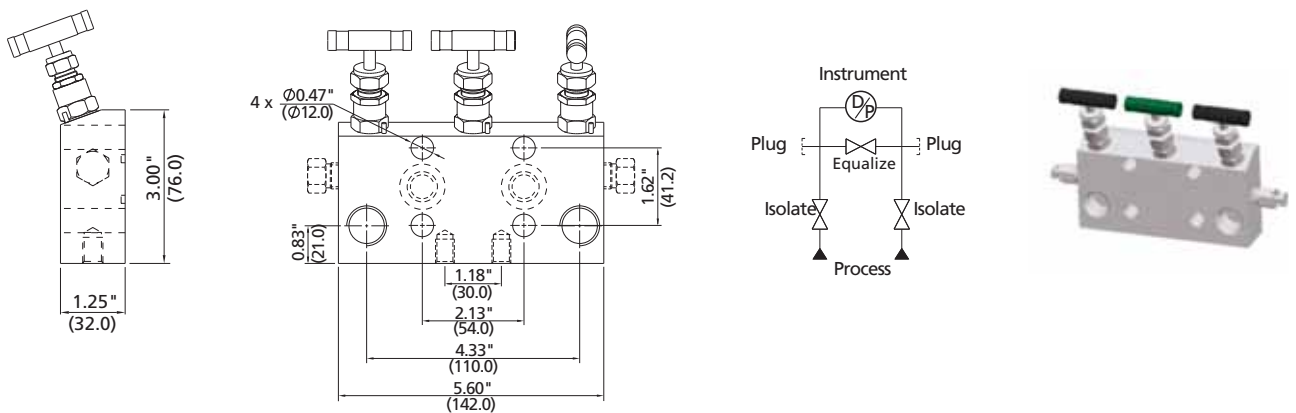

- Notes: 1. Every manifold is supplied with two PTFE sealing rings for manifold-to-instrument and four 7/16" UNF x 1.75" high tensile bolts.
 2. FL8 connections are obtained by adding an extra CM tube fitting to the FNS8 connections.

Basic Ordering Number	Inlet/Process	Outlet/Instrument	Test
3D□□-FNS8-V	1/2 Female NPT	Flange	Optional

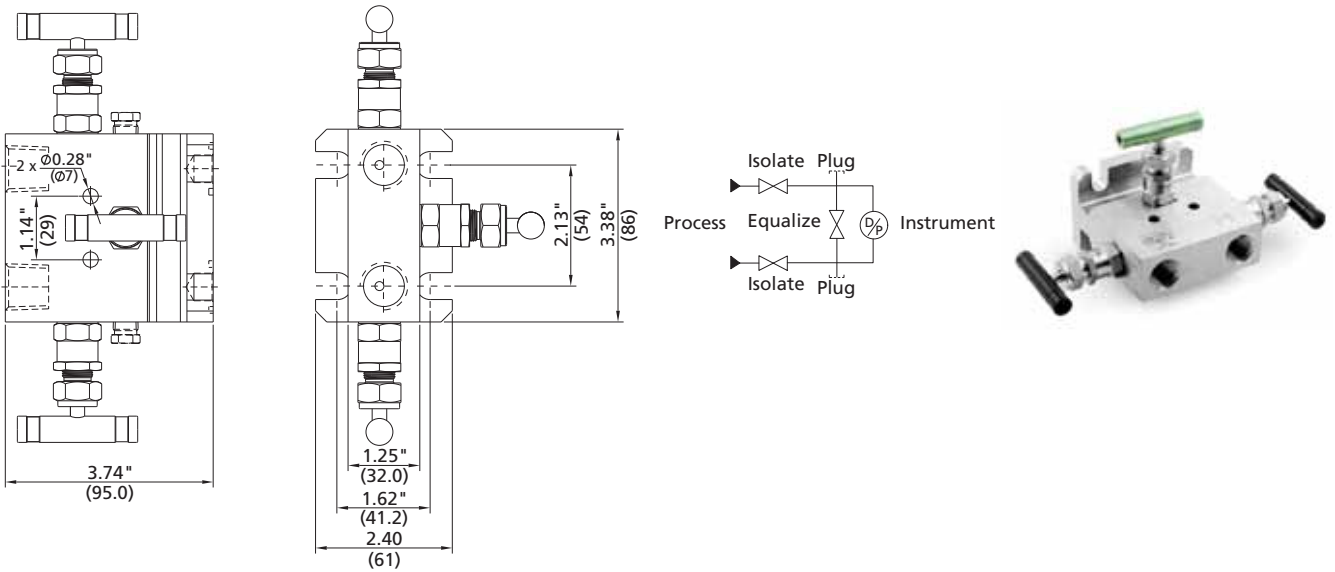

Every manifold is supplied with two PTFE sealing ring for manifold-to-instrument and four 7/16" UNF x 24 mm high tensile bolts.

Basic Ordering Number	Inlet/Process	Outlet/Instrument	Test
3D□□-F-V	Flange	Flange	Optional

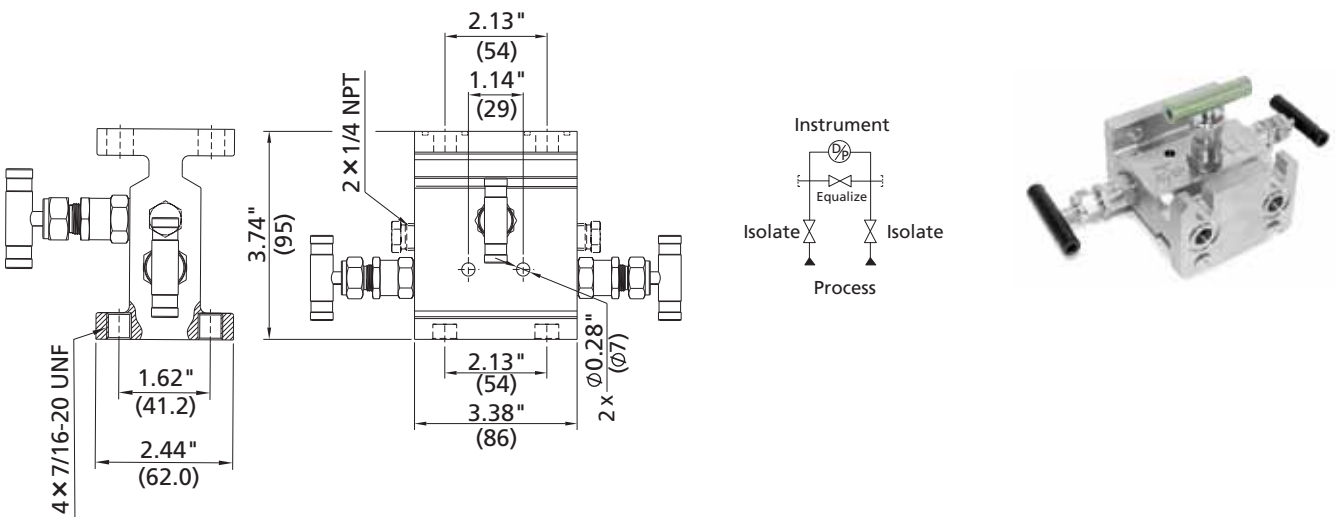

Every manifold is supplied with two PTFE sealing ring for manifold-to-instrument and four 7/16" UNF x 24 mm high tensile bolts.

Manifolds

C-14 Gauge Valves and Instrumentation Manifolds

Basic Ordering Number	Inlet/Process	Outlet/Instrument	Test
3R □□ -FNS8-V	1/2 Female NPT	1/2 Female NPT	Optional
3RH □□ -FNS8-V			
3R □□ -FL8-V	1/2" FITOK	1/2" FITOK	Optional

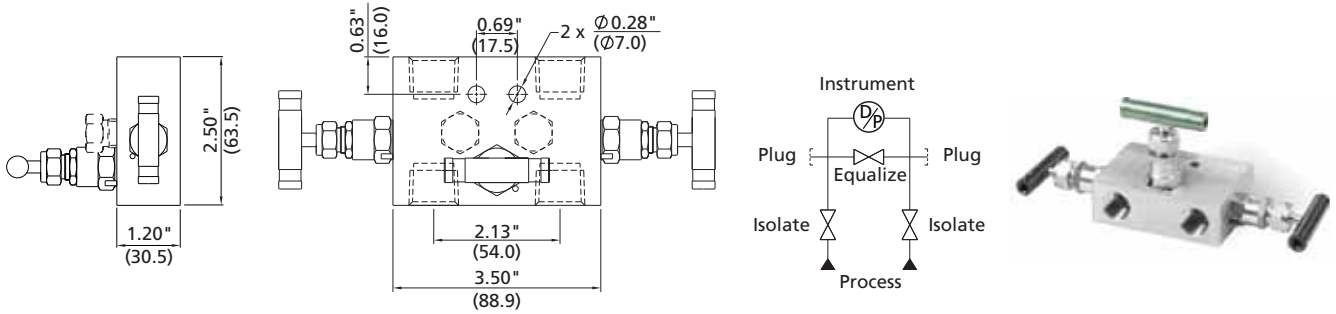

Notes: 1. FL8 connections are obtained by adding an extra CM tube fitting to the FNS8 connections.

2. Dimensions shown are for 3R Series manifolds. For dimensions of 3RH Series manifolds, please contact FITOK Group or our authorized distributors.

5-valve Manifolds

1. 5-valve Manifold of Double-bleed Function:

consist of two block valves, two bleed valves and one equalizer valve

Basic Ordering Number	Inlet/Process	Outlet/Instrument	Test
5D □□ -FNS8-A	1/2 Female NPT	Flange	1/4 Female NPT
5DH □□ -FNS8-A			
5D □□ -FL8-A	1/2" FITOK	Flange	1/4 Female NPT

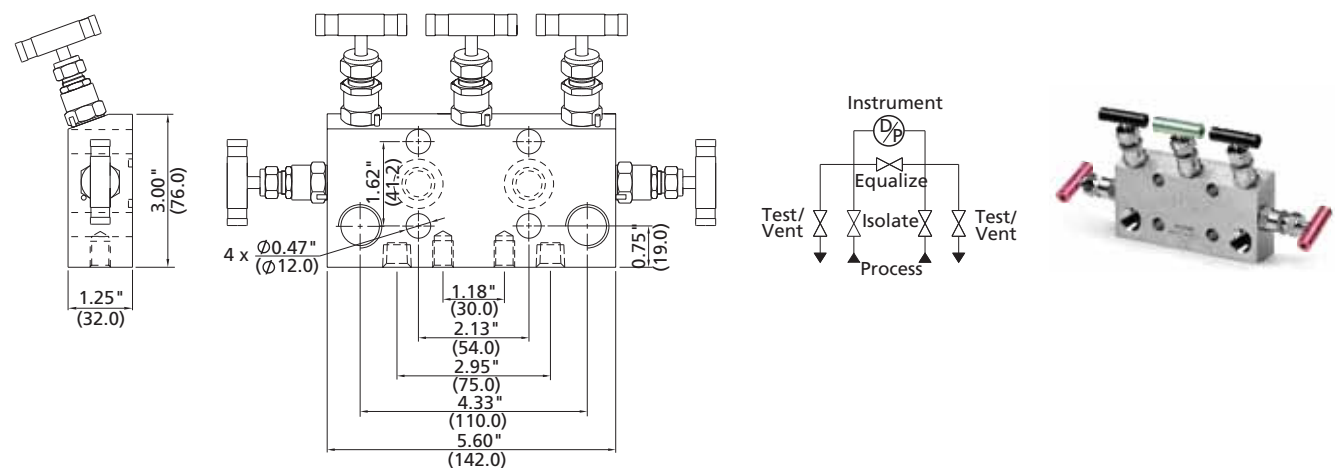

Notes: 1. Every manifold is supplied with two PTFE sealing rings for manifold-to-instrument and four 7/16" UNF x 1.75" high tensile bolts.

2. FL8 connections are obtained by adding an extra CM tube fitting to the FNS8 connections.

3. Dimensions shown are for 5D Series manifolds. For dimensions of 5DH Series manifolds, please contact FITOK Group or our authorized distributors.

Basic Ordering Number	Inlet/Process	Outlet/Instrument	Test/Vent
5D□□-FNS8-V	1/2 Female NPT	Flange	1/4 Female NPT

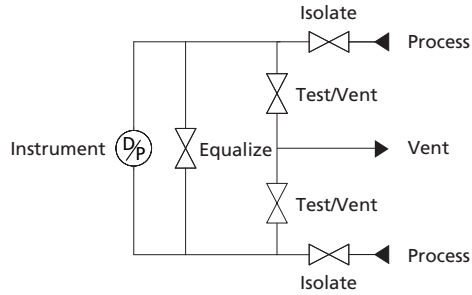
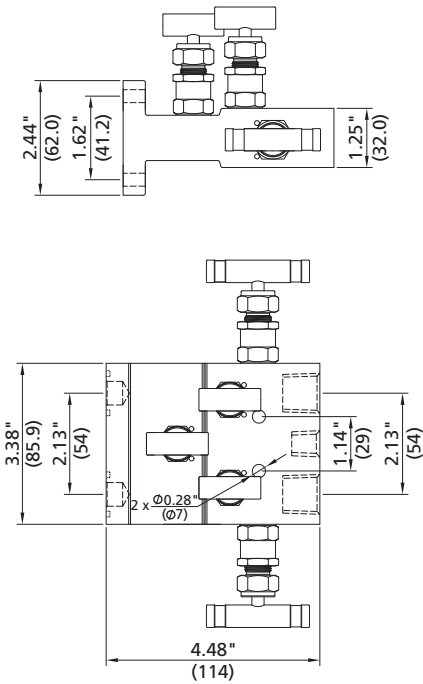

Every manifold is supplied with two PTFE sealing ring for manifold-to-instrument and four 7/16" UNF x 24 mm high tensile bolts.

Basic Ordering Number	Inlet/Process	Outlet/Instrument	Test/Vent
5R□□-FNS8-L	1/2 Female NPT	1/2 Female NPT	1/4 Female NPT
5RH□□-FNS8-L			
5R□□-FL8-FNS8-L	1/2" FITOK	1/2 Female NPT	1/4 Female NPT

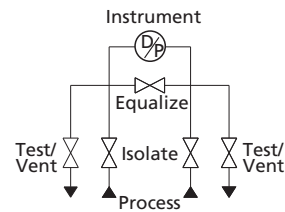
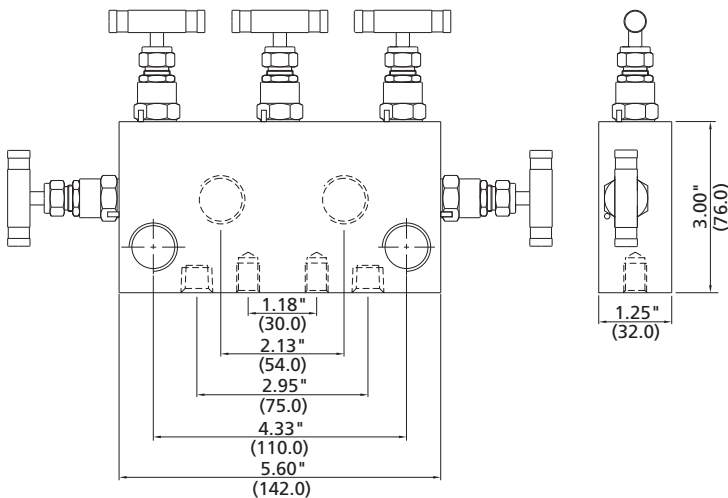

- Notes: 1. FL8 connections are obtained by adding an extra CM tube fitting to the FNS8 connections.
- 2. Dimensions shown are for 5R Series manifolds. For dimensions of 5RH Series manifolds, please contact FITOK Group or our authorized distributor.

C-16 Gauge Valves and Instrumentation Manifolds

Basic Ordering Number	Inlet/Process	Outlet/Instrument	Test/Vent
5R□□-FNS8-V	1/2 Female NPT	1/2 Female NPT	1/4 Female NPT

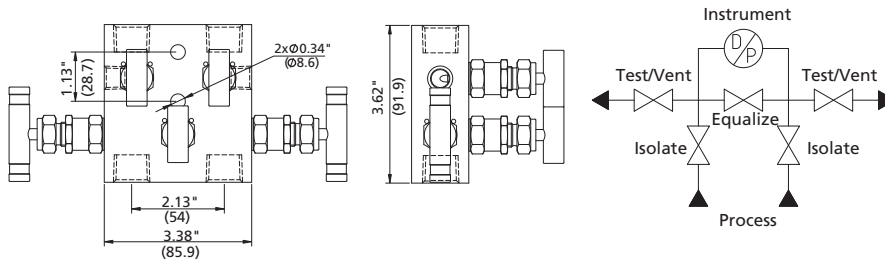

2. 5-valve Custody Transfer/Fiscal Metering Manifold (double-equalizer): consist of two block valves, one bleed valve and two equalizer valves

Basic Ordering Number	Inlet/Process	Outlet/Instrument	Vent	Test
5D□□-FNS8-AB	1/2 Female NPT	Flange	1/4 Female NPT	Optional
5D□□-FL8-AB	1/2" FITOK	Flange	1/4 Female NPT	Optional

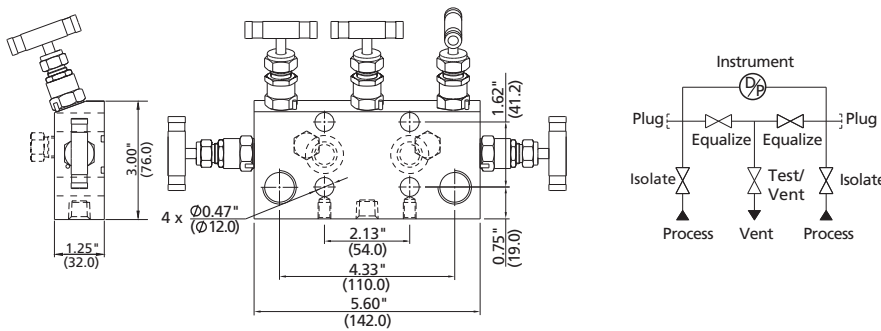

Notes: 1. Every manifold is supplied with two PTFE sealing rings for manifold-to-instrument and four 7/16" UNF x 1.75" high tensile bolts.
2. FL8 connections are obtained by adding an extra CM tube fitting to the FNS8 connections.

Basic Ordering Number	Inlet/Process	Outlet/Instrument	Vent	Test
5D□□-FNS8-VB	1/2 Female NPT	Flange	1/4 Female NPT	Optional

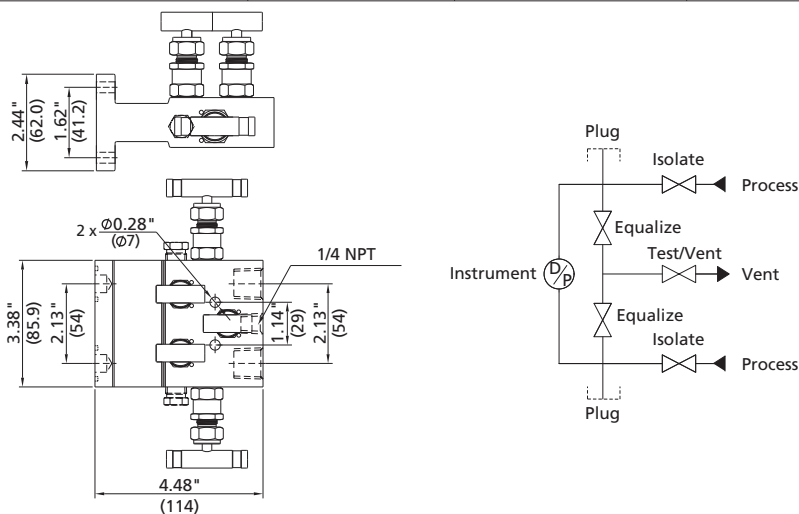

Every manifold is supplied with two PTFE sealing ring for manifold-to-instrument and four 7/16" UNF x 24 mm high tensile bolts.

Basic Ordering Number	Inlet/Process	Outlet/Instrument	Vent	Test
5D□□-F-VB	Flange	Flange	1/4 Female NPT	Optional

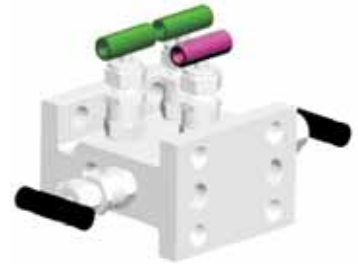
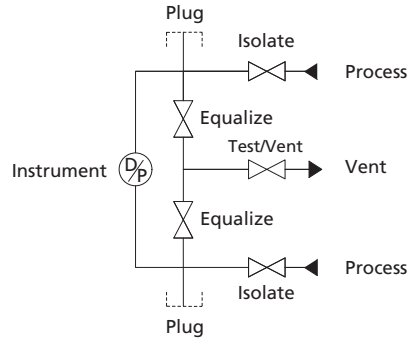
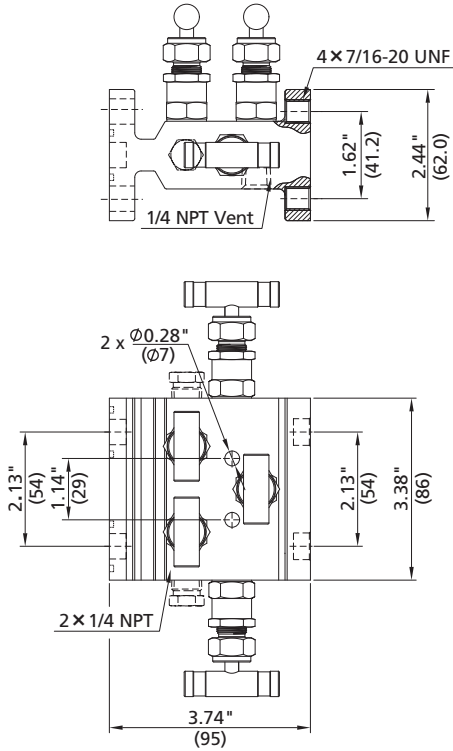

Every manifold is supplied with two PTFE sealing ring for manifold-to-instrument and four 7/16" UNF x 24 mm high tensile bolts.

Basic Ordering Number	Inlet/Process	Outlet/Instrument	Test/Vent
5R□□-FNS8-VB	1/2 Female NPT	1/2 Female NPT	1/4 Female NPT

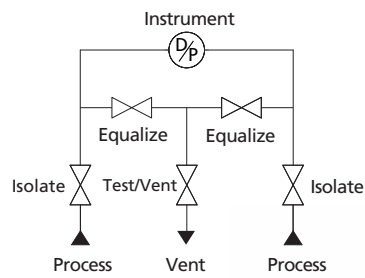
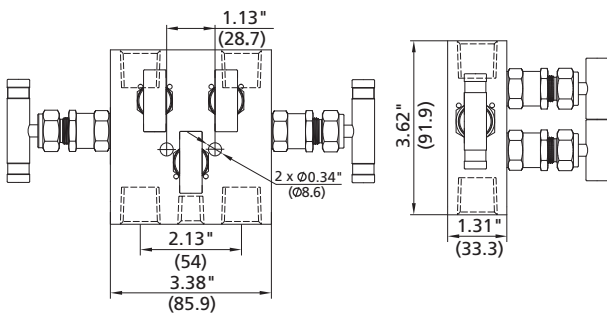

Manifolds

C-18 Gauge Valves and Instrumentation Manifolds

Basic Ordering Number	Inlet/Process	Outlet/Instrument	Vent	Test
5R□□-FNS8-AB	1/2 Female NPT	1/2 Female NPT	1/4 Female NPT	Optional
5R□□-FL8-FNS8-AB	1/2" FITOK	1/2 Female NPT	1/4 Female NPT	Optional

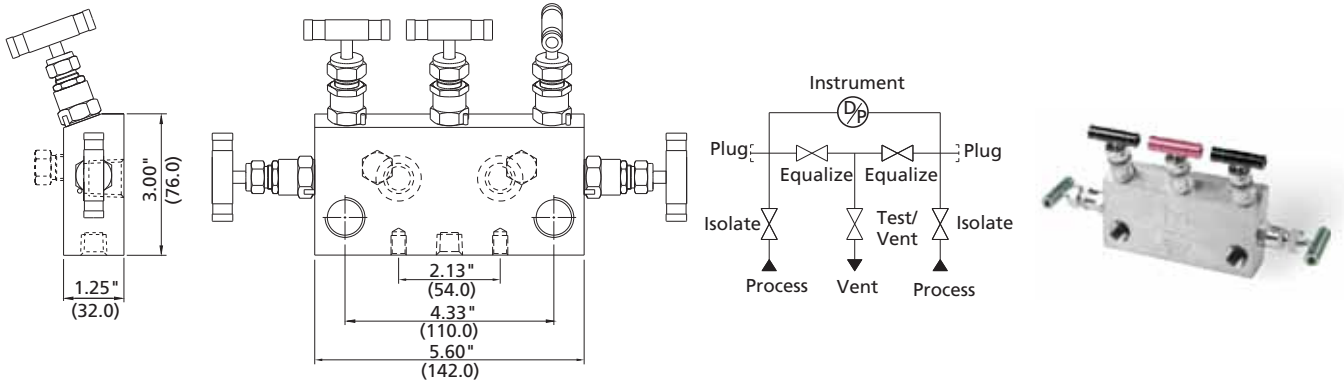

FL8 connections are obtained by adding an extra CM tube fitting to the FNS8 connections.

C Integral Manifolds

C Integral Manifold is specifically designed for the pressure transmitters of Rosemount® coplanar™, including Model 3051C, 3051S, 2024 and 3095. It can be assembled directly to transmitters, eliminating the need for flanges. Each of the following manifolds contains four 7/16" UNF x 2" high tensile bolts.

Basic Ordering Number	Inlet/Process	Outlet/Instrument	Test/Vent
2D□□-FNS8-C	1/2 Female NPT	Flange	1/4 Female NPT
2DH□□-FNS8-C			

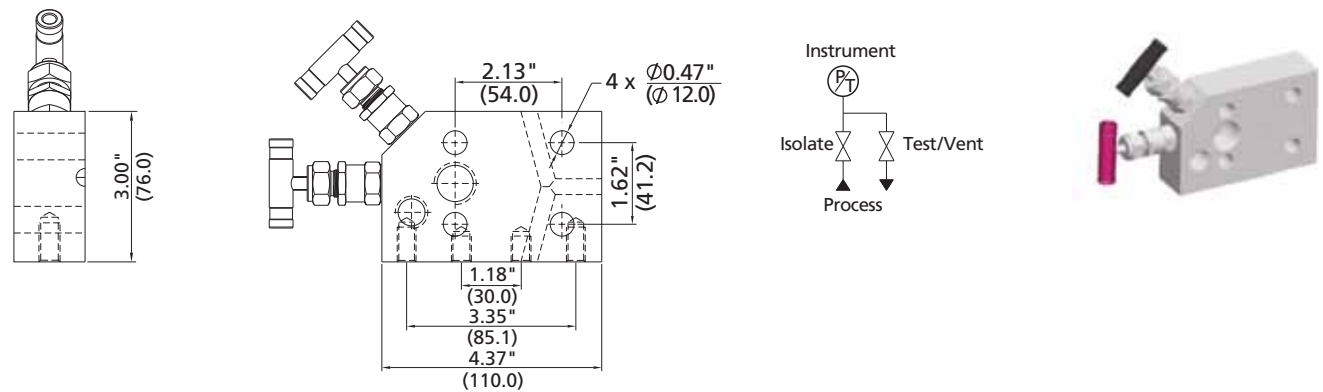

Basic Ordering Number	Inlet/Process	Outlet/Instrument	Test/Vent
3D □□ -FNS8-C	1/2 Female NPT	Flange	Optional
3DH □□ -FNS8-C			
3D □□ -FL8-C	1/2" FITOK	Flange	Optional

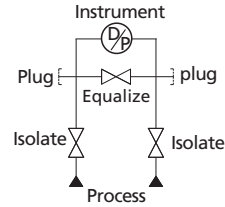
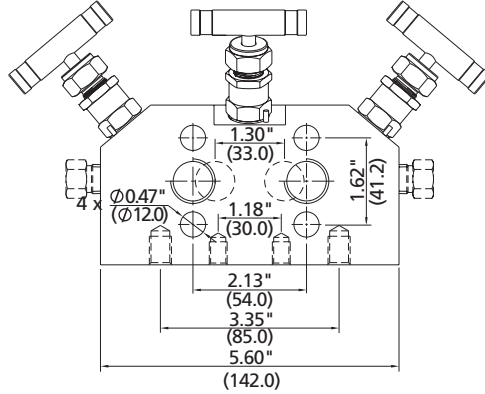
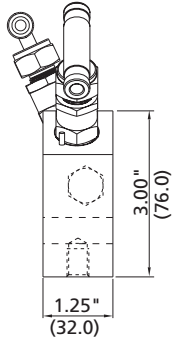

Basic Ordering Number	Inlet/Process	Outlet/Instrument	Test/Vent
5D □□ -FNS8-C	1/2 Female NPT	Flange	1/4 Female NPT
5DH □□ -FNS8-C			
5D □□ -FL8-C	1/2" FITOK	Flange	1/4 Female NPT

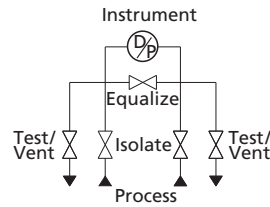
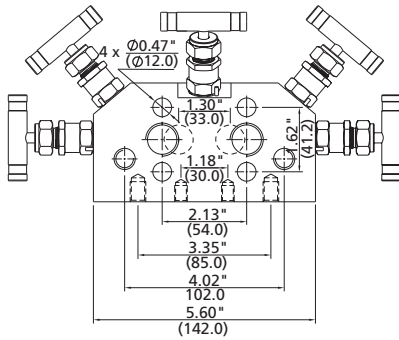
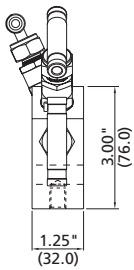

Dimensions shown are for 2D/3D/5D Series manifolds. For dimensions of 2DH/3DH/5DH Series manifolds, please contact FITOK Group or our authorized distributors.
 FL8 connections are obtained by adding an extra CM tube fitting to the FNS8 connections.

Ordering Number Description

3DSS - FNS8 - LG - ET - 1M - SF2

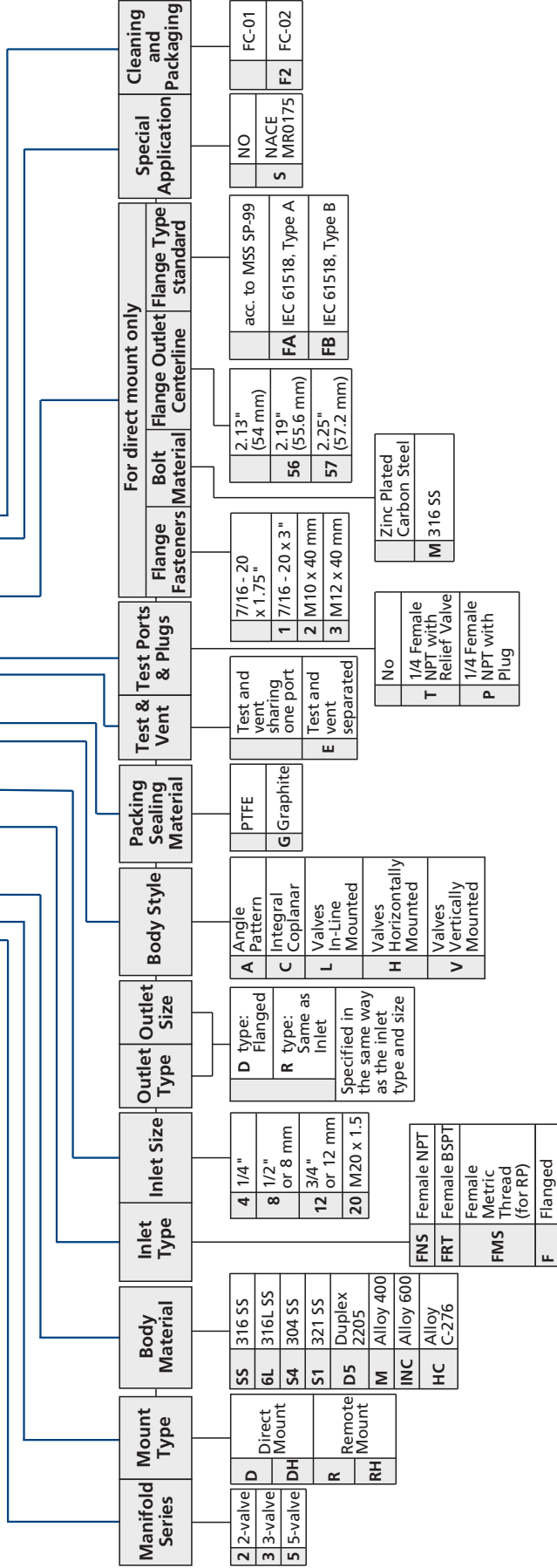

Notes:

- To order 5-valve manifolds with double-equalize function, add B to the Body Style of the manifold ordering number. Example: 5DSS-FNS8-AB
- Plug options are as follows:
 - 1) if option of test and vent sharing one port with plug is needed, add "-P" to the ordering number. Example: 5DSS - FNS8 - AB - P;
 - 2) If option of test and vent separating with a plug to the test port is needed, add "-EP" to the ordering number. Example: 5DSS - FNS8 - AB - EP;
 - 3) If option of test and vent separating with plug for each port is needed, add "-E2P" to the ordering number. Example: 5DSS - FNS8 - AB - E2P.
- The standard center line distance of direct mounting flange outlet of 3-valve manifold and 5-valve manifold is 2.13" (54 mm).
 Center line distance of 2.188" (55.6 mm) is suitable for range 6 and 7, 1151 series transmitter.
 Center line distance of 2.250" (57.2 mm) is suitable for range 8, 1151 series transmitter.
- The standard configuration of direct mounting manifold contains PTFE flange seal ring and 7/16-20 UNF X 1.75" high tensile bolts, can be connected with transmitters under main brands, such as EJA, Honeywell, Foxboro 843 dlp, and Rosemount® 151, 2024, 3051H series.
- 7/16-20 UNF x 3" high tensile bolts can be supplied, can be used for coplanar mounting of the Rosemount® 3051C transmitter with process flange and the manifold.
- Cleaning and Packaging:
 FC-01: Standard cleaning and packaging for general industrial procedures.
 FC-02: Special cleaning and packaging for wetted system components to ensure compliance with product cleanliness requirement as stated in ASTM G93 Level C.
- "Ordering Number Description" is a reference to understand the combination rules of FITOK product part number. Not all combinations are available.

Accessories

Manifold Bracket Supports

SS-M2P-2BK

1. The integral assembly includes: bracket, U-bolts, bolts, gaskets, nuts
2. Fits with 2R□□-XX-A, 2R□□-XX-L, 2RH□□-XX-A

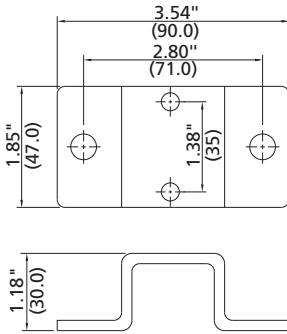

3. SS-M2P-2BK-50 fits with 2R□□-XX-V
4. SS-M2P-2BK-17.5 fits with 3R□□-XX-V
5. SS-M2P-2BK-28.7 fits with 5R□□-XX-VB, 5R□□-XX-V

SS-M2P-6BK

1. The integral assembly includes: bracket, U-bolts, bolts, gaskets, nuts
2. Fits with 2D□□-XX-C, 3D□□-XX-C, 5D□□-XX-C, 2DH□□-XX-C, 3DH□□-XX-C, 5DH□□-XX-C

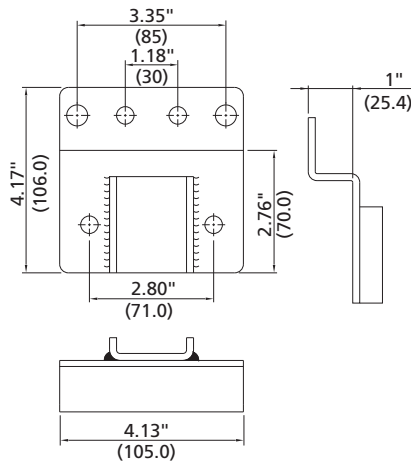

SS-M2P-4BK

1. The bracket support is available for horizontal or vertical installation
2. The integral assembly includes: bracket, U-bolts, bolts, gaskets, nuts
3. Fits with 2D□□-XX-A, 2D□□-XX-L, 3D□□-XX-A, 3D□□-XX-L, 5D□□-XX-A, 5D□□-XX-AB, 5R□□-XX-L, 5R□□-XX-AB, 2DH□□-XX-A, 3DH□□-XX-A, 5DH□□-XX-A, 5RH□□-XX-AB

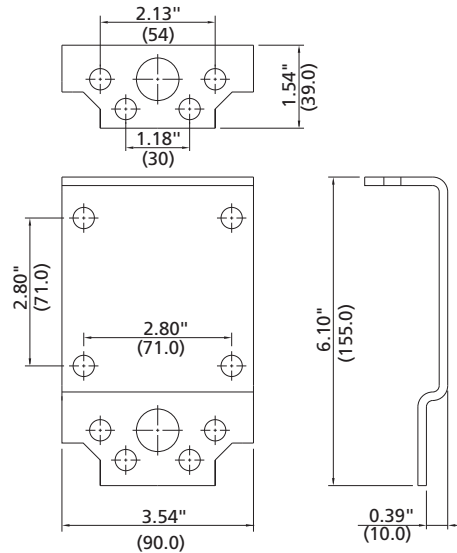

SS-M2P-8BK

1. The bracket support is available for horizontal or vertical installation
2. The integral assembly includes: bracket, U-bolts, bolts, gaskets, nuts
3. Fits with 2D□□-XX-A, 3D□□-XX-A, 3D□□-XX-L, 2D□□-XX-C, 3D□□-XX-C, 5D□□-XX-C

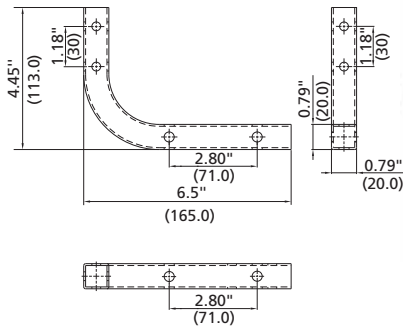

For more installation information regarding other manifolds, please contact FITOK Group or our authorized distributors.

Kidney Flanges and Eccentric Flanges

Features

- Working temperature:
 - PTFE: -65°F to 450°F (-54°C to 232°C)
 - Graphite: -65°F to 1200°F (-54°C to 649°C)
- Integral forged body
- Standard material: A182 F316

Types and Dimensions

Kidney Flanges

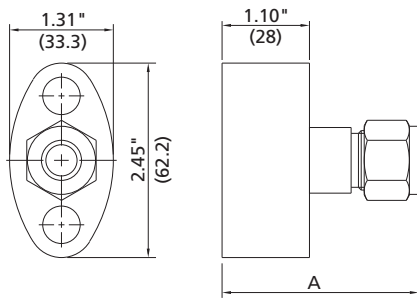

Eccentric Flanges

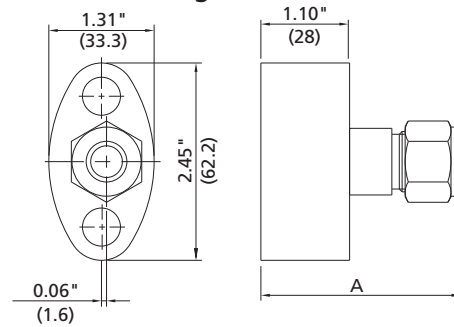

The process connection type of transmitter can be transformed to other connection types.

Ordering Information

Basic Ordering Number	Connection Type and Size	Dimension in. (mm)
		A
SS-KF-FNS4	1/4 Female NPT	1.10 (28)
SS-KF-FNS8	1/2 Female NPT	1.10 (28)
SS-KF-FL8	1/2" FITOK	2.48 (63)
SS-KF-PB8	1/2 PB	2.10 (53.3)

A kidney flange set contains a PTFE flange seal ring and two 7/16 - 20 UNF high tensile bolts.

Ordering Information

Basic Ordering Number	Connection Type and Size	Dimension in. (mm)
		A
SS-EF-FNS4	1/4 Female NPT	1.10 (28)
SS-EF-FNS8	1/2 Female NPT	1.10 (28)
SS-EF-FL8	1/2" FITOK	2.48 (63)
SS-EF-PB8	1/2 PB	2.10 (53.3)

1. Eccentric flange needs to be ordered in whole set.
2. A whole eccentric flange set contains two eccentric flanges, two PTFE flange seal rings and four 7/16 - 20 UNF high tensile bolts.

The Selection of Flange Seal Materials

The standard flange seal material is PTFE, graphite is an option. To order graphite flange seal material, add "- G" as a suffix.

Various Combinations of Eccentric Flange Set

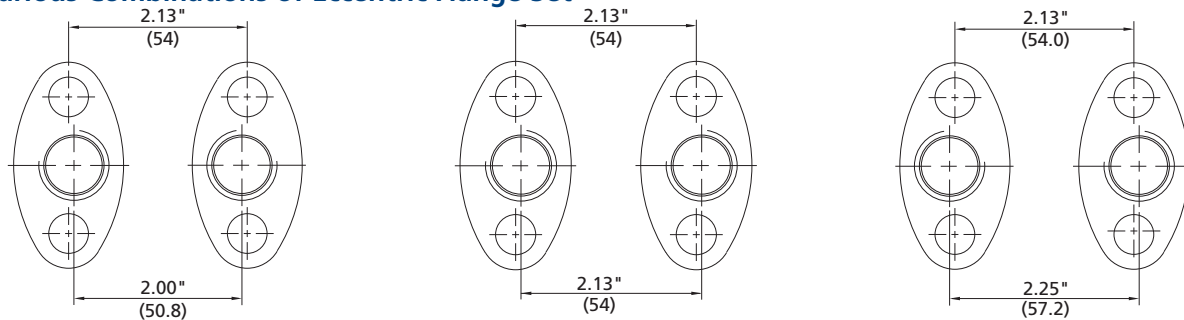

Combinations of eccentric flange set can give different center line distances of 2.0" (50.8 mm), 2.13" (54 mm) and 2.25" (57 mm).

Bleed Valves

- RB Series RBSS-NS4 Bleed Valve is used as standard test/vent valve.
- For more information, refer to FITOK Bleed Valve RB Series.

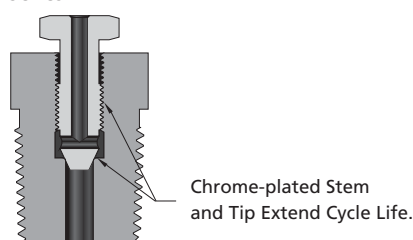

Calibration Fittings

- The calibration fittings can be connected directly with the bleed port of transmitter so that the calibration process can be simplified.
- For more information, refer to FITOK Calibration Fittings.

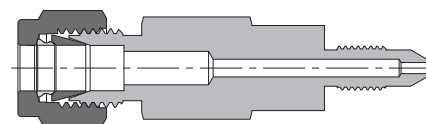

FITOK Group

Headquarter and Factory

FITOK GmbH

Sprendlinger Landstr. 115, 63069 Offenbach am Main, Germany

Tel.: +49 69 8900 4498 Fax: +49 69 8900 4495

Global Sales and Service Center

FITOK, Inc.

13843 North Promenade Blvd., Suite 750, Stafford, Texas 77477, USA

Tel.: +1 281 888 0077 Fax: +1 281 582 4051

Factory and Shared Service Center

FITOK Incorporated

1-4F, Block C, Zone E, Yingtai Industrial Park, Dalang street, Longhua District, Shenzhen, 518109, China

Tel.: +86 755 2803 2500 Fax: +86 755 2803 2619

Factory

FITOK (Suzhou) Metal Products Co., Ltd.

No. 29 Changsheng Road, Yangyuan Industrial Park, Xinzhuang Town, Changshu, Jiangsu 215562, China

Tel.: +86 512 5247 9001 Fax: +86 512 5247 9002

Regional Sales and Service Center

FITOK Middle East Oil Equipment Trading LLC

208-209, Makateb Building, P.O Box 185412, Airport Road, Deira, Dubai, UAE

Tel.: +971 4 2959 853 Fax: +971 4 2959 854

Regional Sales and Service Center

FITOK Canada Inc.

5407 Roper Rd. Edmonton, Alberta, Canada, T6B 3L6

Tel.: +1 780 966 8895

info@fitokgroup.com

www.fitokgroup.com

FK-IC-GV-12-EN-190311