

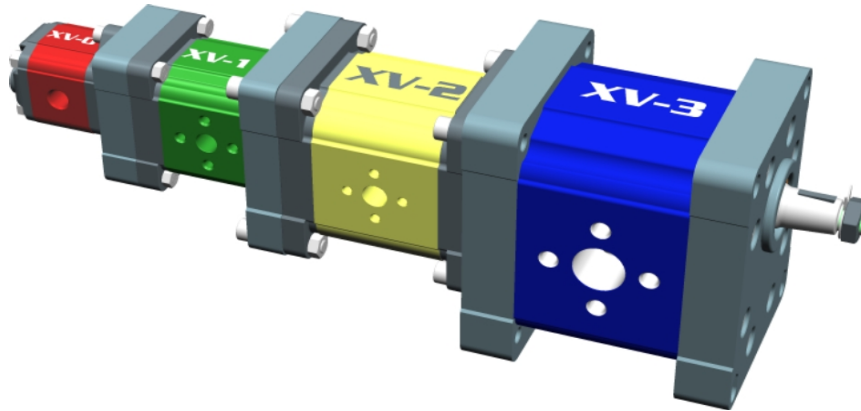

Symbols of Vivoil Oleodinamica Vivoil products



<b>XV-0P</b>	<b>Unidirectional Pump</b>	Left Rotation	Right Rotation
<b>XV-1P</b>			
<b>XV-2P</b>			
<b>XV-3P</b>			

<b>XV-0U</b>	<b>Unidirectional Motor</b>	Left Rotation	Right Rotation
<b>XV-1U</b>			
<b>XV-2U</b>			
<b>XV-3U</b>			

<b>XV-0R</b>	<b>Reversible Pump</b>	External drainage	Internal drainage
<b>XV-1R</b>			
<b>XV-2R</b>			
<b>XV-3R</b>			

<b>XV-0M</b>	<b>Reversible Motor</b>	External drainage	Internal drainage
<b>XV-1M</b>			
<b>XV-2M</b>			
<b>XV-3M</b>			

<b>XV-0T</b>	<b>XV-1T</b>	<b>XV-2T</b>	<b>XV-3T</b>	<b>Primary element of multiple pump</b>	
<b>XV-0I</b>	<b>XV-1I</b>	<b>XV-2I</b>	<b>XV-3I</b>		<b>Intermediate element of multiple pump</b>
<b>XV-0F</b>	<b>XV-1F</b>	<b>XV-2F</b>	<b>XV-3F</b>		<b>Final element of multiple pump</b>

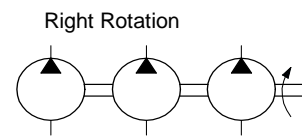
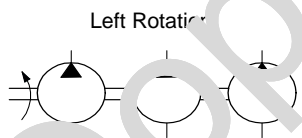

<b>KV-DF</b>	<b>Flow divider</b>

<b>KV-DFV</b>	<b>Flow divided with valves</b>

<b>KV-DF+M</b>	<b>Flow divider with motor</b>

# MULTIPLE PUMPS – SINGLE ELEMENTS

## MULTIPLE PUMPS CATALOGUE - Introduction

The catalogue is mainly composed in two sections, reflecting the possible supply manners:

- Single elements  
*Dimensions, characteristics and codification of the single elements composing the multiple pumps*
- Assembled pumps  
*Dimensions, characteristics and codes of assembled pumps*

The variety of variants allows a high number of possible alternatives. Both the sections try to give an instrument to consult easily to create the ideal solution.

## ASSEMBLED PUMPS

In the following section it's represented how to compose the assembled multiple pumps. For each driving pump, identified by the connection flange, two or more pages are prepared as showed in the image below. In particular you may find:

1. Three-dimensional representation of the assembled pump typology
2. Different coupling solutions
3. Special solutions
4. Dimensional and features summary table.
5. Product Code structure and corresponding **purchasing code** starting from the specific features that can be chosen from the possible solution
6. Displacement for the primary pump.

**POMPA MULTIPLA XV-1**  
BASE ø 30

**STADI SEPARATI**      **ASPIRAZIONE UNICA**

TIPO	Cilindrata	A	A1	B	B1	C	C1	P1	P2	Regime Max	Regime Max
Configto	mm	mm	mm	mm	mm	mm	mm	bar	bar	g/min	g/min
XV1/1.0	0.91	74.5	37.5	74.5	37.5	78	37.5	240	200	700	8000
XV1/1.25	1.17	75.5	37.5	75.5	37.5	79	37.5	250	200	700	8500
XV1/1.5	1.56	77	38.5	77	38.5	80.5	38.5	250	200	700	9000
XV1/1.75	2.06	79	39.5	79	39.5	82	39.5	250	200	700	9500
XV1/2.0	2.66	81	40.5	81	40.5	84.5	40.5	250	200	700	10000
XV1/2.5	3.12	83	41.5	83	41.5	86	41.5	250	200	700	10500
XV1/3.0	3.64	85	42.5	85	42.5	88.5	42.5	250	200	700	11000
XV1/3.5	4.26	87	43.5	87	43.5	90.5	43.5	250	200	700	11500
XV1/4.0	4.94	89	45	89	45	93	45	250	200	700	12000
XV1/4.5	5.68	91	46.5	91	46.5	95.5	46.5	250	200	700	12500
XV1/5.0	6.50	95	48	95	48	98.5	48	250	200	700	13000
XV1/5.5	7.44	100	50	100	50	102.5	50	250	200	700	13500
XV1/6.0	8.68	105	52.5	105	52.5	107	52.5	250	200	700	14000

TIPO	Cilindrata	D	D1	E	E1	F	F1	G	G1	P1	P2	Regime Max	Regime Max
Configto	mm	mm	mm	mm	mm	mm	mm	mm	mm	bar	bar	g/min	g/min
XV1/1.0	0.16	12.3	46.5	13.8	46.5	15.4	26.3	12.3	26.3	22	210	700	8000
XV1/1.25	0.24	12.3	46.5	16.4	46.5	18.4	26.5	12.3	26.5	22	210	700	8000
XV1/1.5	0.45	14.5	47.5	18	47.5	19	27.3	14.5	27.3	22	210	700	8000
XV1/1.75	0.56	15.5	47.5	19	47.5	19	27.3	15.5	27.3	22	210	700	8000
XV1/2.0	0.75	17	48.5	20.5	48.5	20.5	28	17	28	22	210	700	8000
XV1/2.5	0.91	18.5	49.5	21	49.5	21	28	18.5	28	22	210	700	8000
XV1/3.0	1.17	19.5	50.5	22.5	50.5	22.5	28.5	19.5	28.5	22	210	700	8000
XV1/3.5	1.48	21	51.5	24	51.5	24	29	21	29	22	210	700	8000
XV1/4.0	2.28	19	54.5	22.5	54.5	22.5	34.5	19	34.5	22	210	700	8000

**POMPA MULTIPLA XV-1**  
B/ E ø 32 Sagomata - TIPO "BH"

**M STANDARD**  
**S SAGOMATA**  
**T STADI SEPARATI**  
**A ASPIRAZIONE UNICA**

**BASE SINISTRA DESTRA**

**ALBERO CFP02 COP01**  
**SCF02 SCF04**  
**SCF01 SCF03**

**NUMERO DI ELEMENTI**

**CORPO**  
C  
C  
G  
G  
M  
A

**COPERCHIO**  
A  
B  
C  
N

**CILINDRATA**  
16 XV-PP0.6  
17 XV-PP1.2  
18 XV-PP1.7  
20 XV-PP2.1  
21 XV-PP2.5  
23 XV-PP3.2  
25 XV-PP3.5  
27 XV-PP4.5  
29 XV-PP4.8  
31 XV-PP5.5  
34 XV-PP7.2  
38 XV-PP8.5

**CILINDRATA**  
41 XV-PP0.17  
42 XV-PP0.25  
44 XV-PP0.45  
45 XV-PP0.67  
46 XV-PP0.78  
48 XV-PP0.88  
49 XV-PP1.27  
51 XV-PP1.52  
53 XV-PP2.38

Vinci OleodinamicaVinci s.r.l. - Società a Sede Unica - via Lancia Giordano 2-4 40054 Busto (BO) Italy Tel: +39 051 899689 Fax: +39 051 899981  
www.vincicosp.com - info@vincicosp.com

## MULTIPLE PUMPS – SINGLE ELEMENTS

### DIMENSIONAL CHECK

The correct dimensioning of a multiple pump requires an opportune verification on the mechanical resistance considering the specific working conditions. Therefore **IT IS RECOMMENDED** to do a dimensional check during the engineering phase in order to have a coherent choice with the real system capabilities.

The required data for the verification are mainly the **displacements** and **the working pressures** of each element. Starting from these basic data it is possible to find out the torque that is created on each driving shaft, both analytically than graphically.

#### ANALYTICAL PROCEDURE

To calculate analytically the transmitted torque, we assume that

- $v_i$  = element displacement expressed in cc/rev.
- $\Delta p$  = pressure difference between inlet and outlet expressed in bar
- $\eta_m$  = mechanical efficiency that we can assume as 0.9

The transmitted torque is obtained by this simple equation.

$$T_{elem} = \frac{v_i \times \Delta p}{20 \times \pi \times \eta_m}$$

#### GRAPHICAL PROCEDURE

The identification of the torque transmitted by each single element can be obtained graphically starting from the below tables. When the Pressure/Torque table corresponding to the dimensional group is identified, choose the line on the graphic regarding the element displacement. Starting from the outlet pressure, get the corresponding torque.

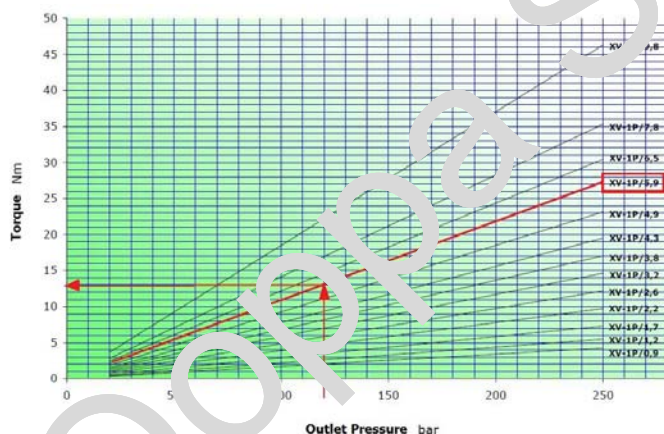

The verification requires to compare the obtained torque value with the one recommended for each typology of connection or connecting shaft.

To each element, starting from the final one, the torque coming from the previous ones must be added, using the following scheme:

<b>FINAL ELEMENT VERIFICATION</b>	$T_{elem\_fin} \leq T_{fin}$
<b>INTERMEDIATE ELEMENT VERIFICATION</b>	$T_{elem\_int} + T_{elem\_int\_preced} + T_{elem\_fin} \leq T_{int}$
<b>DRIVING ELEMENT VERIFICATION</b>	$T_{elem\_prim} + \dots + T_{elem\_int} + \dots + T_{elem\_fin} \leq T_{prim}$

## MULTIPLE PUMPS – SINGLE ELEMENTS

The recommended values are summarized in the following tables:

### TORQUES ALLOWED ON DRIVING PUMP SHAFT:

	SHAFT [IDENTIFIER] - CODE - DESCRIPTION	T Max [Nm]
XV-0P	[A] - CI001 - Parallel $\varnothing$ 7 - M 7x1 - key thk sp.2	2.1
	[B] - CF001 - Milled shank $\varnothing$ 7 - sp. 5	9,2
	[F] - CF005 - Milled shank $\varnothing$ 7 - sp.4,5 L = 9	8.4
XV-1P	[A] - CI001 - Parallel $\varnothing$ 12 - M10x1 - key thk. 3	25,8
	[B] - CI002 - Parallel $\varnothing$ 12.7 - key thk. 3.2 (SAE)	32,8
	[C] - CF001 - Milled shank $\varnothing$ 10 - thk.5 ("BH" Standard German)	13,8
	[D] - CF002 - Milled shank $\varnothing$ 10 - thk.5	13,8
	[E] - CF003 - Milled shank $\varnothing$ 11 - thk.6.63 (SAE)	25,8
	[F] - CO001 - Tapered 1:8 - $\varnothing$ 10 - M7x1 - key thk.2.4	43
	[G] - CO002 - Tapered 1:8 - $\varnothing$ 14 - M10x1 - key thk.3	119,8
	[I] - CO004 - Tapered 1:8 - $\varnothing$ 12.7 - 5/16" 24UNF-2A - key thk.3.2 (SAE)	90.4
	[J] - SCF04 - Splined $\varnothing$ 11.7 - z=6, H=17.5, m=1.6, DIN 5482 12x9	22
	[K] - SCF05 - Splined $\varnothing$ 12.344, z=9, H=19, SAE J498 9T 20/40DB	32,2
	[L] - SCF02 - Splined $\varnothing$ 11.9, z=15, H=17.5, m=0.75	42,8
	[O] - CO002+HK - Tapered 1:8 - $\varnothing$ 14 - M10x1, HK 14-12, key thk.3	119,8
	[P] - CI001+HK - Parallel $\varnothing$ 12 - M10x1 with bearing HK 14-12 - key thk.3	25,8
	[Q] - SCF01 - Splined $\varnothing$ 11.9, z=15, H=9, m=0.75	42,8
	[R] - SCF03 - Splined $\varnothing$ 11.9, z=15, H=9, m=0.75	42,8
	XV-2P	[A] - CI001 - Parallel $\varnothing$ 15 - M6x1 - key thk.4
[B] - CI002 - Parallel $\varnothing$ 15.875 - 1/4"28-UNF key thk.4 (SAE A)		67.5
[C] - CF001 - Miled shank $\varnothing$ 15 - thk.8 ("BH" Standard German)		60.5
[E] - CO001 - Tapered 1:8 - $\varnothing$ 17,4 - M12x1,5 - key thk.4		233.2
[F] - CO002 - Tapered 1:5 - $\varnothing$ 17,4 - M12x1,5 - key thk.3		233.2
[G] - SCF02 - Splined $\varnothing$ 16.5 - z=9, H=18,8, m=1.6 DIN 5482 17x14		86.1
[H] - SCF03 - Splined $\varnothing$ 16.5 - z=9, H=18,8, m=1.6 DIN 5482 17x14		86.1
[I] - SCF04 - Splined $\varnothing$ 16.5 - z=9, H=22.5, SAE J498 9T 16/32DP		67.1
[K] - SCF05 - Splined $\varnothing$ 16.5 - z=9 H=8,1 m=1.6 DIN 5482 17x14		86.2
[L] - SCF01 - Splined $\varnothing$ 16.5 z=9 H=9,2 m=1.6 DIN 5482 17x14		86.2
[M] - CO001 - Tapered 1:8 - $\varnothing$ 17,4 - M12x1,5 - key thk.3,2	233.2	
XV-3P	[A] - CO001 - Tapered 1:8 - $\varnothing$ 22 - M14x1.5 - key thk.4	482
	[B] - CI001 - Parallel $\varnothing$ 20 - M8 - key thk.5	181
	[C] - SCF03 - Splined $\varnothing$ 21.5, z=13, H=25, m=1,6	223
	[H] - CI004 - Parallel $\varnothing$ 22.225- 1/4"28-UNF key thk.6.35 (SAE B)	180
	[I] - SCF04 - Splined $\varnothing$ 21.8059, z=13, H=25, SAE J498 9T 16/32DP	264

## MULTIPLE PUMPS – SINGLE ELEMENTS

TORQUES ALLOWED ON FINAL AND INTERMEDIATE PUMP SHAFT:

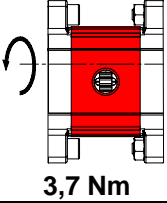
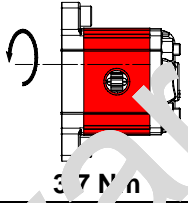
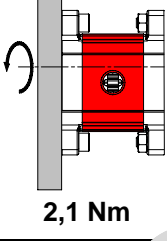
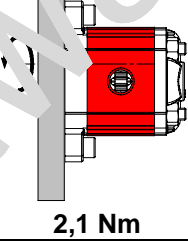
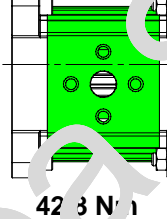
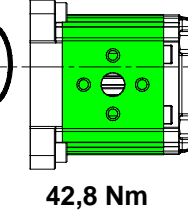
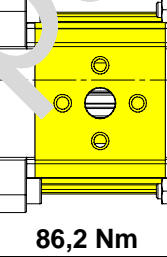
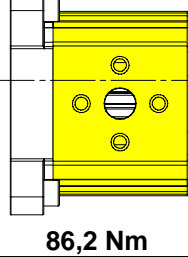
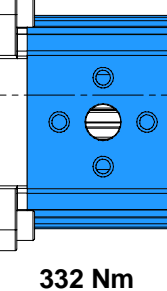
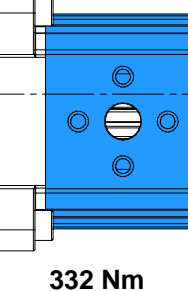
Composition	Intermediate Pump Couple $T_{int}$	Final Pump Couple $T_{fin}$
0P + 0P	 <p>3,7 Nm</p>	 <p>3,7 Nm</p>
1P + 0P 2P + 0P 3P + 0P	 <p>2,1 Nm</p>	 <p>2,1 Nm</p>
1P + 1P 2P + 1P 3P + 1P	 <p>42,8 Nm</p>	 <p>42,8 Nm</p>
2P + 2P 3P + 3P	 <p>86,2 Nm</p>	 <p>86,2 Nm</p>
3P + 3P	 <p>332 Nm</p>	 <p>332 Nm</p>

## MULTIPLE PUMPS – SINGLE ELEMENTS

**Example** of quadruple pump verification with primary taper shaft COP02:

Element typology	Displacement	Working Pressure
Driving	22 cc	150 bar
Intermediate 1	5.9 cc	120 bar
Intermediate 2	5.9 cc	100 bar
Final	1.2 cc	100 bar

Consequently through the calculation or graphical analysis

Motive Torque
58.39 Nm
12.53 Nm
10.44 Nm
2.12 Nm

The verification therefore is, starting from the final element:

### Final element

$$T_{elem\_fin} \leq T_{fin} \quad 2.12 \text{ Nm} < \quad \text{OK}$$

### Intermediate Element 2

$$T_{elem\_int} + T_{elem\_int\_preced} + T_{elem\_fin} \leq T_{int} \quad 2.12 + 10.44 \text{ Nm} = 12.56 \text{ Nm} < \quad \text{OK}$$

### Intermediate Element 1

$$T_{elem\_int} + T_{elem\_int\_preced} + T_{elem\_fin} \leq T_{int} \quad 12.56 + 12.53 \text{ Nm} = 25.09 \text{ Nm} < \quad \text{OK}$$

### Driving Element

$$T_{elem\_prim} + \dots + T_{elem\_int} + \dots + T_{elem\_fin} \leq T_{prim} \quad 25.09 + 58.39 \text{ Nm} = 83.48 \text{ Nm} < 233.2 \text{ Nm} \quad \text{OK}$$

### General Notes:

For assemblies with a coupling, you should choose one as balanced as possible in order to reduce the vibrations and dynamic stresses to which the pump shaft may be subject.

Always make sure that the torque applied is less than or equal to the admissible torque of the shaft.

Do not apply a direct axial or radial load on the pump shaft; if necessary, use suitable supports.

Always use well-filtered oils containing no water or other emulsifying substance.

Never run the pump with oil and air solutions.

For pumps with outlets on the flange, it is recommended not to exceed a flow rate of

4 l/min	XV-0P
20 l/min.	XV-1P
35 l/min	XV-2P

# MULTIPLE PUMP XV-0

Ø 22 FLANGE

**XV-0**

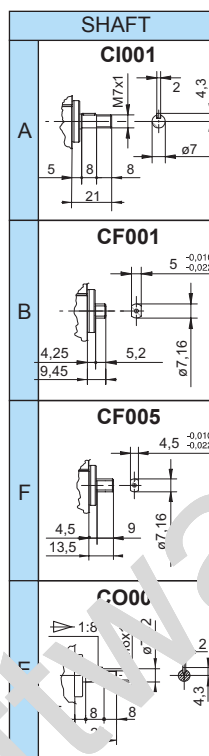
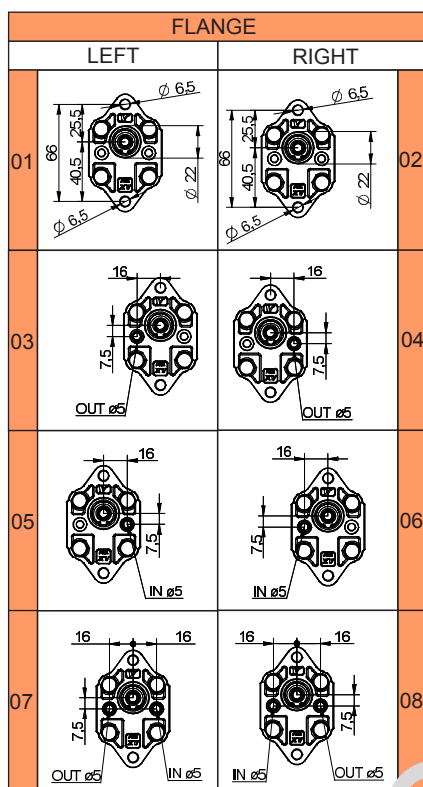
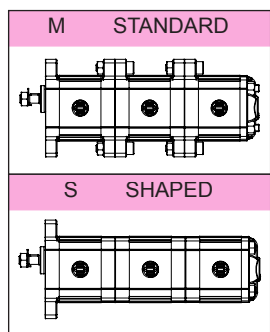

NUMBER OF ELEMENTS

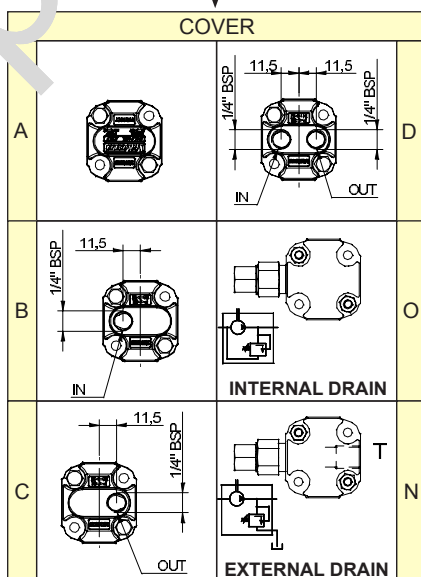
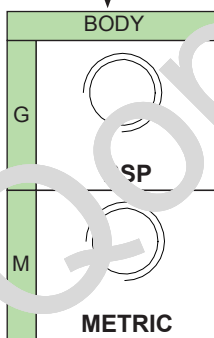

DISPLACEMENT	
01	XV-0P/0.17
02	XV-0P/0.25
04	XV-0P/0.45
05	XV-0P/0.57
06	XV-0P/0.76
07	XV-0P/0.98
09	XV-0P/1.27
11	XV-0P/1.52
13	XV-0P/2.30

# MULTIPLE PUMP XV-0

Ø 22 FLANGE

**XV-0**

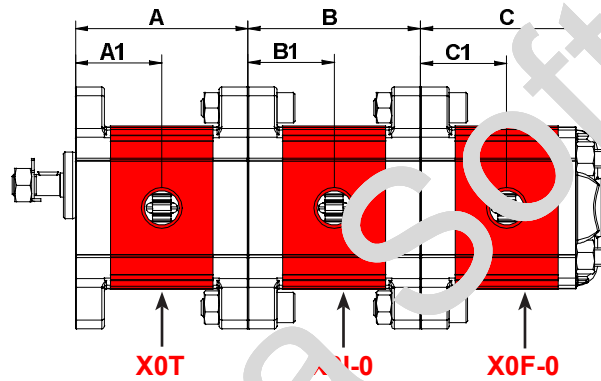
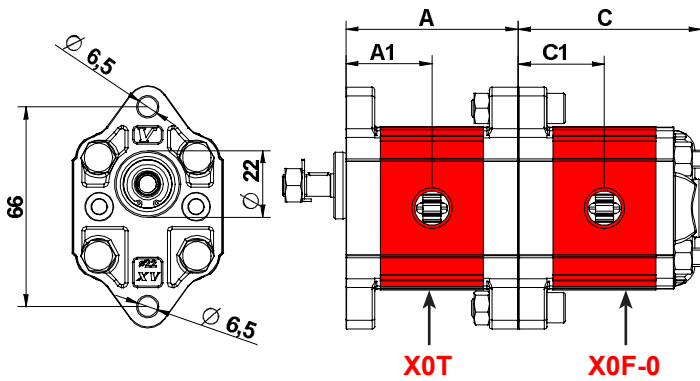
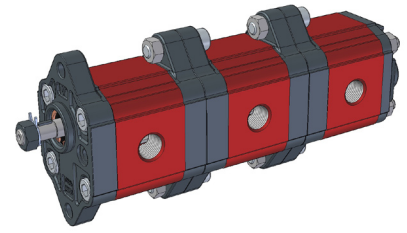

TYPE	Displacem	A	B	B1	C	C1	P1	P3	Min speed	Max speed
	cc/rev	mm	mm	mm	mm	mm	bar	bar	rpm	rpm
XV-0 / 0,17	0,17	52,3	26,2	52,3	26,2	55,8	220	260	700	9000
XV-0 / 0,25	0,25	52,3	26,5	52,9	26,5	56,4	220	260	700	9000
XV-0 / 0,45	0,45	54,5	27,3	54,5	27,3	58	220	280	700	9000
XV-0 / 0,57	0,56	55,5	27,8	55,5	27,8	59	220	280	700	9000
XV-0 / 0,76	0,75	57	28,5	57	28,5	60,5	220	280	700	9000
XV-0 / 0,98	0,92	58,5	29,3	58,5	29,3	62	220	280	700	6000
XV-0 / 1,27	1,26	61	30,5	61	30,5	64,5	220	280	700	6000
XV-0 / 1,52	1,48	63	31,5	63	31,5	66,5	220	280	700	6000
XV-0 / 2,30	2,28	69	34,5	69	34,5	72,5	220	210	700	5000



# MULTIPLE PUMP XV-0

ø 22 "BH" Body-Shaped FLANGE

**XV-0**

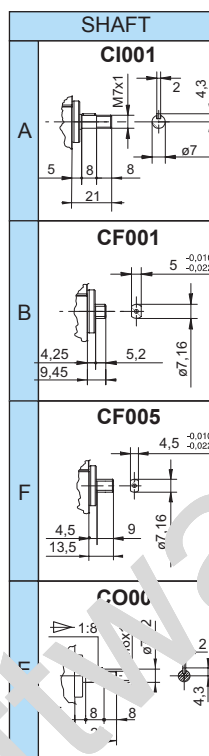
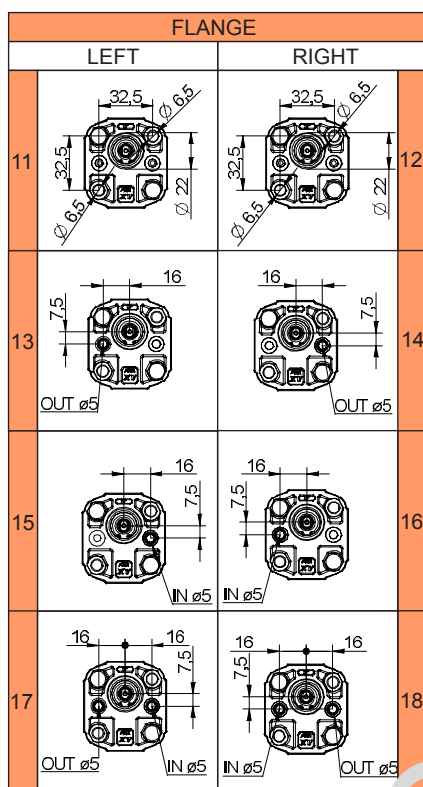
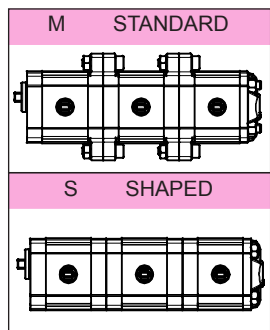

NUMBER OF ELEMENTS

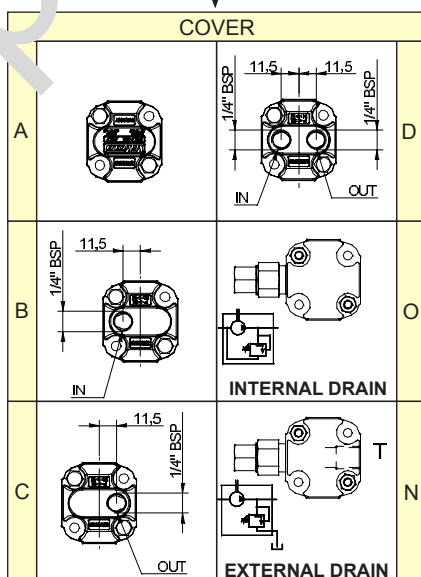
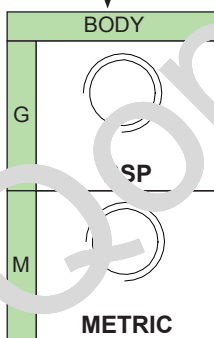

DISPLACEMENT	
01	XV-0P/0.17
02	XV-0P/0.25
04	XV-0P/0.45
05	XV-0P/0.57
06	XV-0P/0.76
07	XV-0P/0.98
09	XV-0P/1.27
11	XV-0P/1.52
13	XV-0P/2.30

# MULTIPLE PUMP XV-0

Ø 22 "BH" Body-Shaped FLANGE

**XV-0**

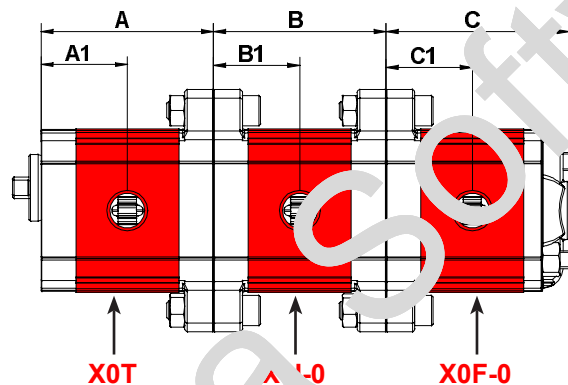
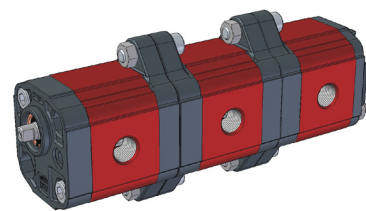
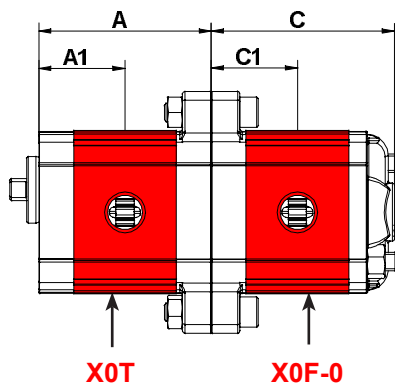
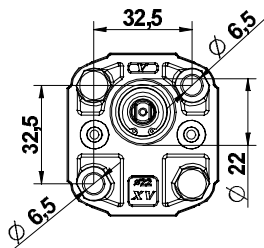

TYPE	Displacem.	A	B	B1	C	C1	P1	P3	Min speed	Max speed
	cc/rev	mm	mm	mm	mm	mm	bar	bar	rpm	rpm
XV-0 / 0,17	0,17	52,3	26,2	52,3	26,2	55,8	220	260	700	9000
XV-0 / 0,25	0,25	52,3	26,5	52,9	26,5	56,4	220	260	700	9000
XV-0 / 0,45	0,45	54,5	27,3	54,5	27,3	58	220	280	700	9000
XV-0 / 0,57	0,56	55,5	27,8	55,5	27,8	59	220	280	700	9000
XV-0 / 0,76	0,75	57	28,5	57	28,5	60,5	220	280	700	9000
XV-0 / 0,98	0,92	58,5	29,3	58,5	29,3	62	220	280	700	6000
XV-0 / 1,27	1,26	61	30,5	61	30,5	64,5	220	280	700	6000
XV-0 / 1,52	1,48	63	31,5	63	31,5	66,5	220	280	700	6000
XV-0 / 2,30	2,28	69	34,5	69	34,5	72,5	220	210	700	5000

# MULTIPLE PUMP XV-0

Ø 22 "HY" Body-Shaped FLANGE

**XV-0**

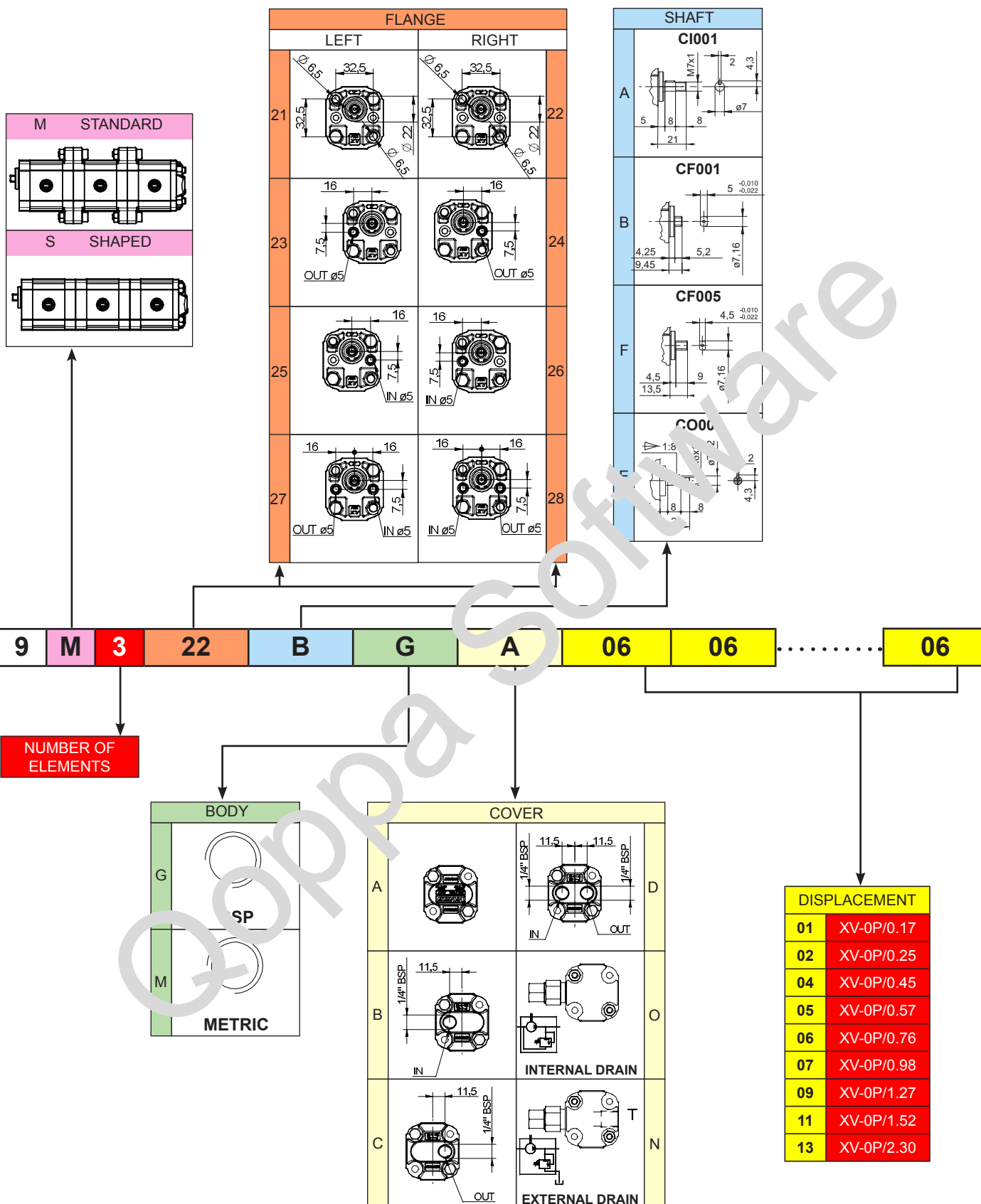

# MULTIPLE PUMP XV-1

Ø 22 "HY" Body-Shaped FLANGE

**XV-0**

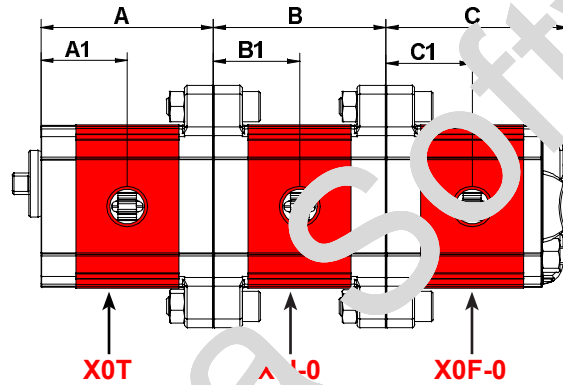
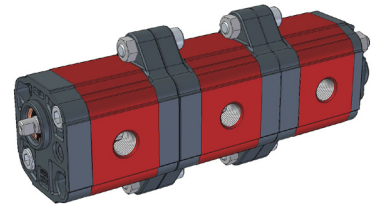
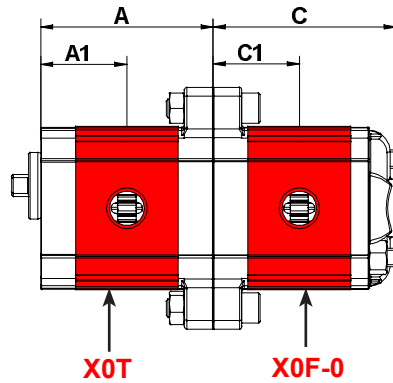
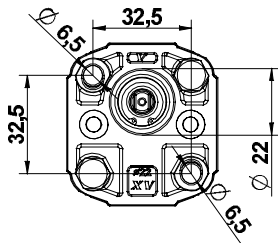

TYPE	Displacem.	A	A1	B	B1	C	C1	P1	P3	Min speed	Max speed
	cc/rev										
XV-0 / 0,17	0,16	52,3	26,2	52,3	26,2	55,8	26,2	220	260	700	9000
XV-0 / 0,25	0,24	52,9	26,5	52,9	26,5	56,4	26,5	220	260	700	9000
XV-0 / 0,45	0,45	54,5	27,3	54,5	27,3	58	27,3	220	280	700	9000
XV-0 / 0,57	0,56	55,5	27,8	55,5	27,8	59	27,8	220	280	700	9000
XV-0 / 0,76	0,75	57	28,5	57	28,5	60,5	28,5	220	280	700	9000
XV-0 / 0,98	0,92	58,5	29,3	58,5	29,3	62	29,3	220	280	700	6000
XV-0 / 1,27	1,26	61	30,5	61	30,5	64,5	30,5	220	280	700	6000
XV-0 / 1,52	1,48	63	31,5	63	31,5	66,5	31,5	220	280	700	6000
XV-0 / 2,30	2,28	69	34,5	69	34,5	72,5	34,5	220	210	700	5000

# MULTIPLE PUMP XV-1

ø 25,4 FLANGE

XV-1

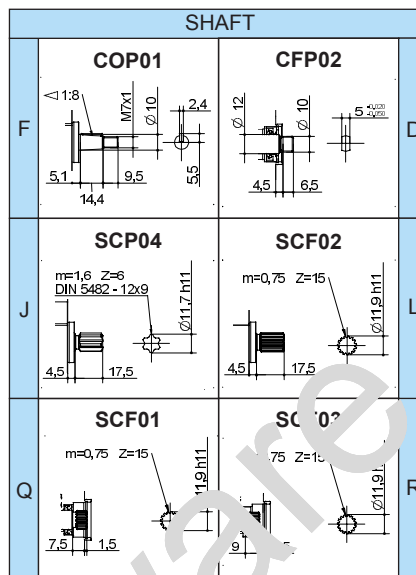
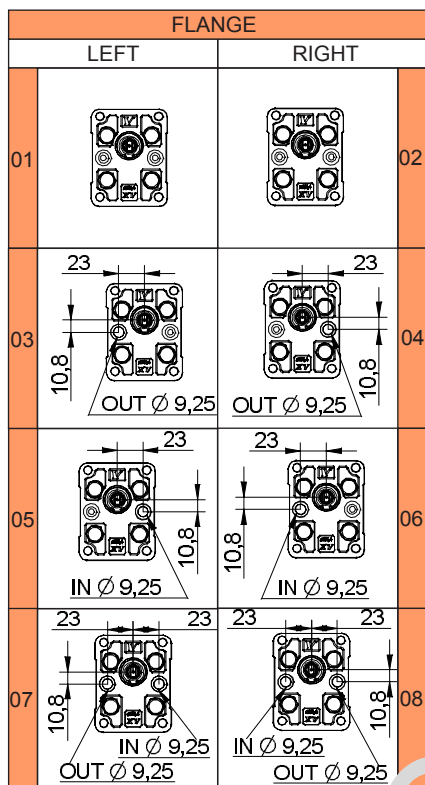
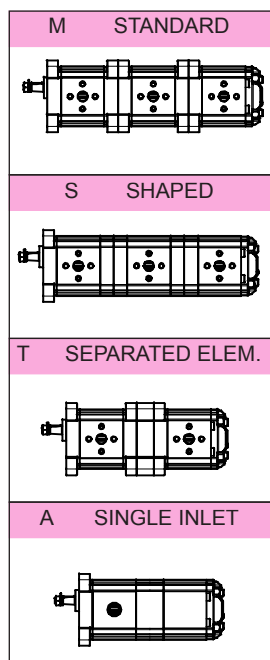

9 M 3 02 F C A 25 25 ..... 25

NUMBER OF ELEMENTS

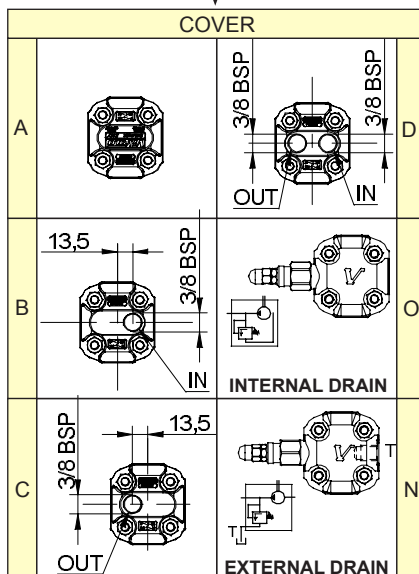
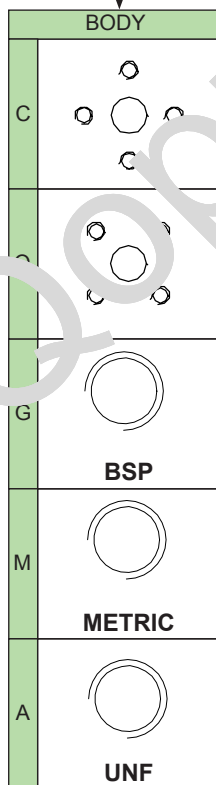

DISPLACEMENT	
16	XV-1P/0.9
17	XV-1P/1.2
18	XV-1P/1.7
20	XV-1P/2.2
21	XV-1P/2.6
23	XV-1P/3.2
25	XV-1P/3.8
27	XV-1P/4.3
29	XV-1P/4.9
31	XV-1P/5.9
32	XV-1P/6.5
34	XV-1P/7.8
36	XV-1P/9.8

DISPLACEMENT	
01	XV-0P/0.17
02	XV-0P/0.25
04	XV-0P/0.45
05	XV-0P/0.57
06	XV-0P/0.76
07	XV-0P/0.98
09	XV-0P/1.27
11	XV-0P/1.52
13	XV-0P/2.30

# MULTIPLE PUMP XV-1

Ø 25,4 FLANGE

XV-1

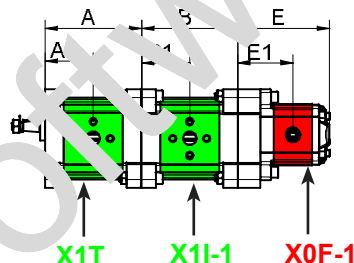
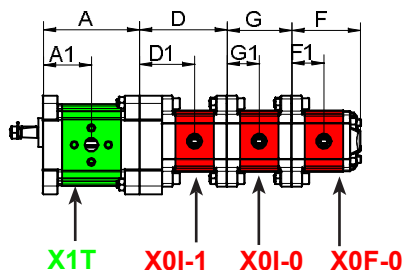
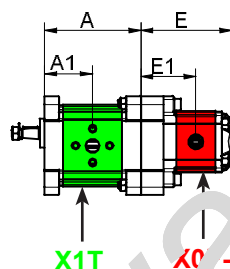
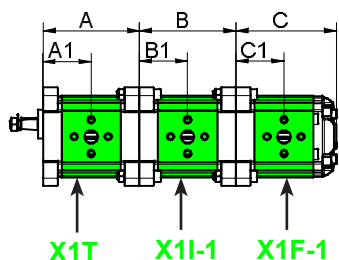
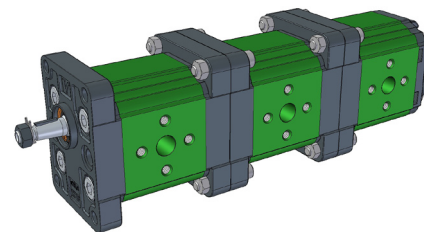
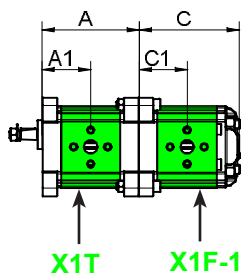
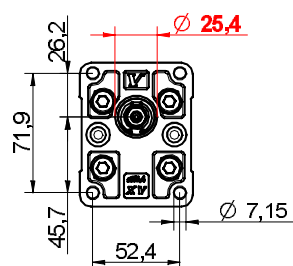

## SEPARATED STAGES

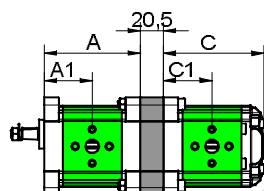

## SINGLE INLET

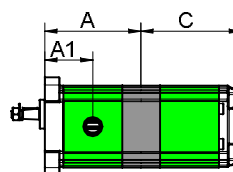

\* = SPECIAL ELEMENT, please contact our customer service for details.

TYPE	Displacement cc/rev	A mm	B1 mm	B mm	B1 mm	C mm	C1 mm	P1 bar	P3 bar	Min speed rpm	Max speed rpm
XV-1 / 0,9	0,91	72,5	47,3	74,5	37,3	78	37,3	240	280	700	6000
XV-1 / 1,2	1,17	75,5	47,8	75,5	37,8	79	37,8	250	290	700	6000
XV-1 / 1,7	1,65	77	38,5	77	38,5	80,5	38,5	250	290	700	6000
XV-1 / 2,2	2,08	79	39,5	79	39,5	82,5	39,5	250	290	700	6000
XV-1 / 2,6	2,60	81	40,5	81	40,5	84,5	40,5	250	300	700	6000
XV-1 / 3,2	3,20	83	41,5	83	41,5	86	41,5	250	300	700	6000
XV-1 / 3,8	3,64	85	42,5	85	42,5	88,5	42,5	250	300	700	6000
XV-1 / 4,3	4,26	87	43,5	87	43,5	90,5	43,5	250	300	700	6000
XV-1 / 4,9	4,94	90	45	90	45	93,5	45	250	300	700	6000
XV-1 / 5,9	5,85	93,5	46,8	93,5	46,8	97	46,8	250	300	700	5000
XV-1 / 6,5	6,50	96	48	96	48	99,5	48	250	300	700	5000
XV-1 / 7,8	7,54	100	50	100	50	103,5	50	220	260	700	5000
XV-1 / 9,8	9,88	109	54,5	109	54,5	112,5	54,5	190	230	700	4000

TYPE	Displacem. cc/rev	D mm	D1 mm	E mm	E1 mm	F mm	F1 mm	G mm	G1 mm	P1 bar	P3 bar	Min speed rpm	Max speed rpm
XV-0 / 0,17	0,16	72,3	46,2	75,8	46,2	55,8	26,2	52,3	26,2	220	260	700	9000
XV-0 / 0,25	0,24	72,9	46,5	76,4	46,5	56,4	26,5	52,9	26,5	220	260	700	9000
XV-0 / 0,45	0,45	74,5	47,3	78	47,3	58	27,3	54,5	27,3	220	280	700	9000
XV-0 / 0,57	0,56	75,5	47,8	79	47,8	59	27,8	55,5	27,8	220	280	700	9000
XV-0 / 0,76	0,75	77	48,5	80,5	48,5	60,5	28,5	57	28,5	220	280	700	9000
XV-0 / 0,98	0,92	78,5	49,3	82	49,3	62	29,3	58,5	29,3	220	280	700	6000
XV-0 / 1,27	1,26	81	50,5	84,5	50,5	64,5	30,5	61	30,5	220	280	700	6000
XV-0 / 1,52	1,48	83	51,5	86,5	51,5	66,5	31,5	63	31,5	220	280	700	6000
XV-0 / 2,30	2,28	89	54,5	92,5	54,5	72,5	34,5	69	34,5	220	210	700	5000

# MULTIPLE PUMP XV-1

Ø 30 FLANGE

XV-1

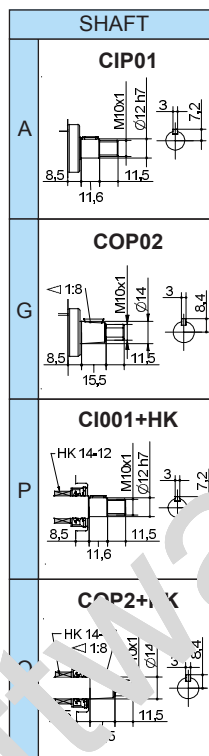
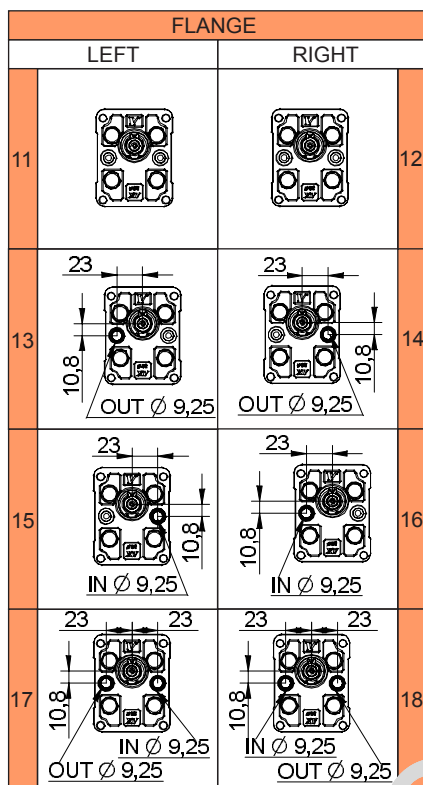
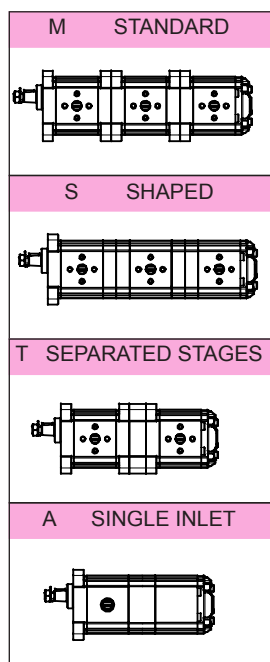

NUMBER OF ELEMENTS

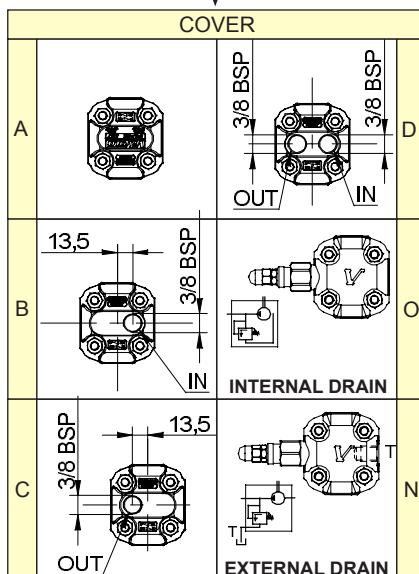
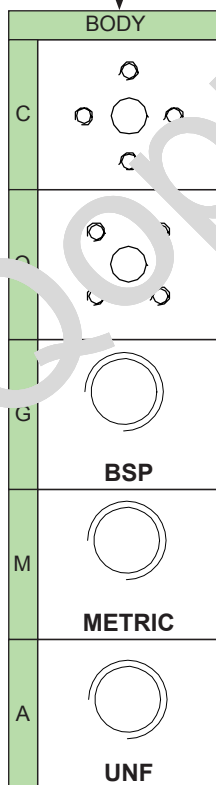

DISPLACEMENT	
16	XV-1P/0.9
17	XV-1P/1.2
18	XV-1P/1.7
20	XV-1P/2.2
21	XV-1P/2.6
23	XV-1P/3.2
25	XV-1P/3.8
27	XV-1P/4.3
29	XV-1P/4.9
31	XV-1P/5.9
32	XV-1P/6.5
34	XV-1P/7.8
36	XV-1P/9.8

DISPLACEMENT	
01	XV-0P/0.17
02	XV-0P/0.25
04	XV-0P/0.45
05	XV-0P/0.57
06	XV-0P/0.76
07	XV-0P/0.98
09	XV-0P/1.27
11	XV-0P/1.52
13	XV-0P/2.30

# MULTIPLE PUMP XV-1

Ø 30 FLANGE

**XV-1**

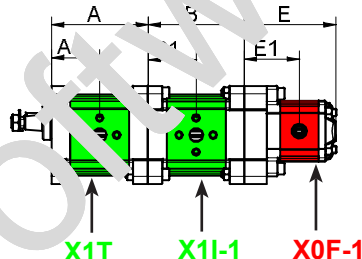
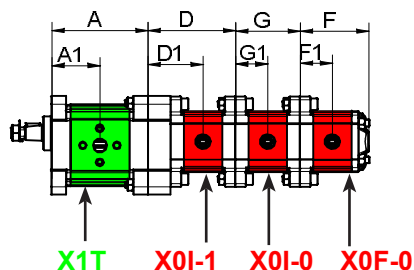
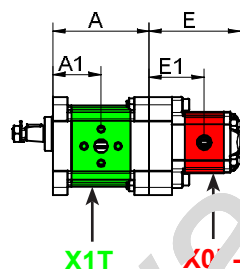
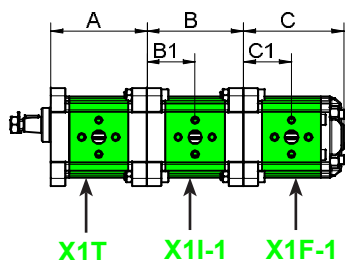
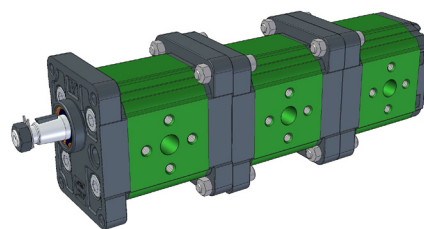
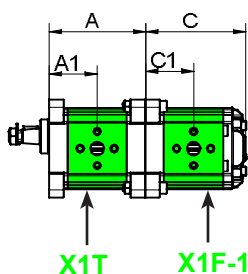
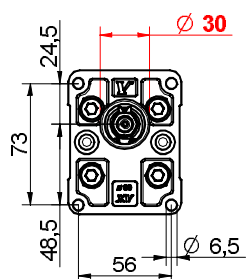

## SEPARATED STAGES

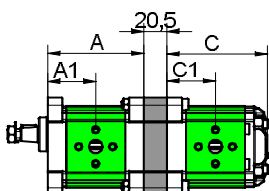

## SINGLE INLET

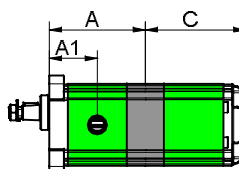

\* = SPECIAL ELEMENT, please contact our customer service for details.

TYPE	Displacement cc/rev	A mm	B1 mm	B mm	B1 mm	C mm	C1 mm	P1 bar	P3 bar	Min speed rpm	Max speed rpm
XV-1 / 0,9	0,91	74,5	47,3	74,5	37,3	78	37,3	240	280	700	6000
XV-1 / 1,2	1,17	75,5	47,8	75,5	37,8	79	37,8	250	290	700	6000
XV-1 / 1,7	1,7	77	48,5	77	38,5	80,5	38,5	250	290	700	6000
XV-1 / 2,2	2,28	79	49,5	79	39,5	82,5	39,5	250	290	700	6000
XV-1 / 2,6	2,60	81	40,5	81	40,5	84,5	40,5	250	300	700	6000
XV-1 / 3,2	3,2	83	41,5	83	41,5	86	41,5	250	300	700	6000
XV-1 / 3,8	3,6	85	42,5	85	42,5	88,5	42,5	250	300	700	6000
XV-1 / 4,3	4,26	87	43,5	87	43,5	90,5	43,5	250	300	700	6000
XV-1 / 4,9	4,94	90	45	90	45	93,5	45	250	300	700	6000
XV-1 / 5,9	5,85	93,5	46,8	93,5	46,8	97	46,8	250	300	700	5000
XV-1 / 6,5	6,50	96	48	96	48	99,5	48	250	300	700	5000
XV-1 / 7,8	7,54	100	50	100	50	103,5	50	220	260	700	5000
XV-1 / 9,8	9,88	109	54,5	109	54,5	112,5	54,5	190	230	700	4000

TYPE	Displacement cc/rev	D mm	D1 mm	E mm	E1 mm	F mm	F1 mm	G mm	G1 mm	P1 bar	P3 bar	Min speed rpm	Max speed rpm
XV-0 / 0,17	0,16	72,3	46,2	75,8	46,2	55,8	26,2	52,3	26,2	220	260	700	9000
XV-0 / 0,25	0,24	72,9	46,5	76,4	46,5	56,4	26,5	52,9	26,5	220	260	700	9000
XV-0 / 0,45	0,45	74,5	47,3	78	47,3	58	27,3	54,5	27,3	220	280	700	9000
XV-0 / 0,57	0,56	75,5	47,8	79	47,8	59	27,8	55,5	27,8	220	280	700	9000
XV-0 / 0,76	0,75	77	48,5	80,5	48,5	60,5	28,5	57	28,5	220	280	700	9000
XV-0 / 0,98	0,92	78,5	49,3	82	49,3	62	29,3	58,5	29,3	220	280	700	6000
XV-0 / 1,27	1,26	81	50,5	84,5	50,5	64,5	30,5	61	30,5	220	280	700	6000
XV-0 / 1,52	1,48	83	51,5	86,5	51,5	66,5	31,5	63	31,5	220	280	700	6000
XV-0 / 2,30	2,28	89	54,5	92,5	54,5	72,5	34,5	69	34,5	220	210	700	5000



# MULTIPLE PUMP XV-1

**XV-1**

ø 32 "BH" Body-Shaped FLANGE

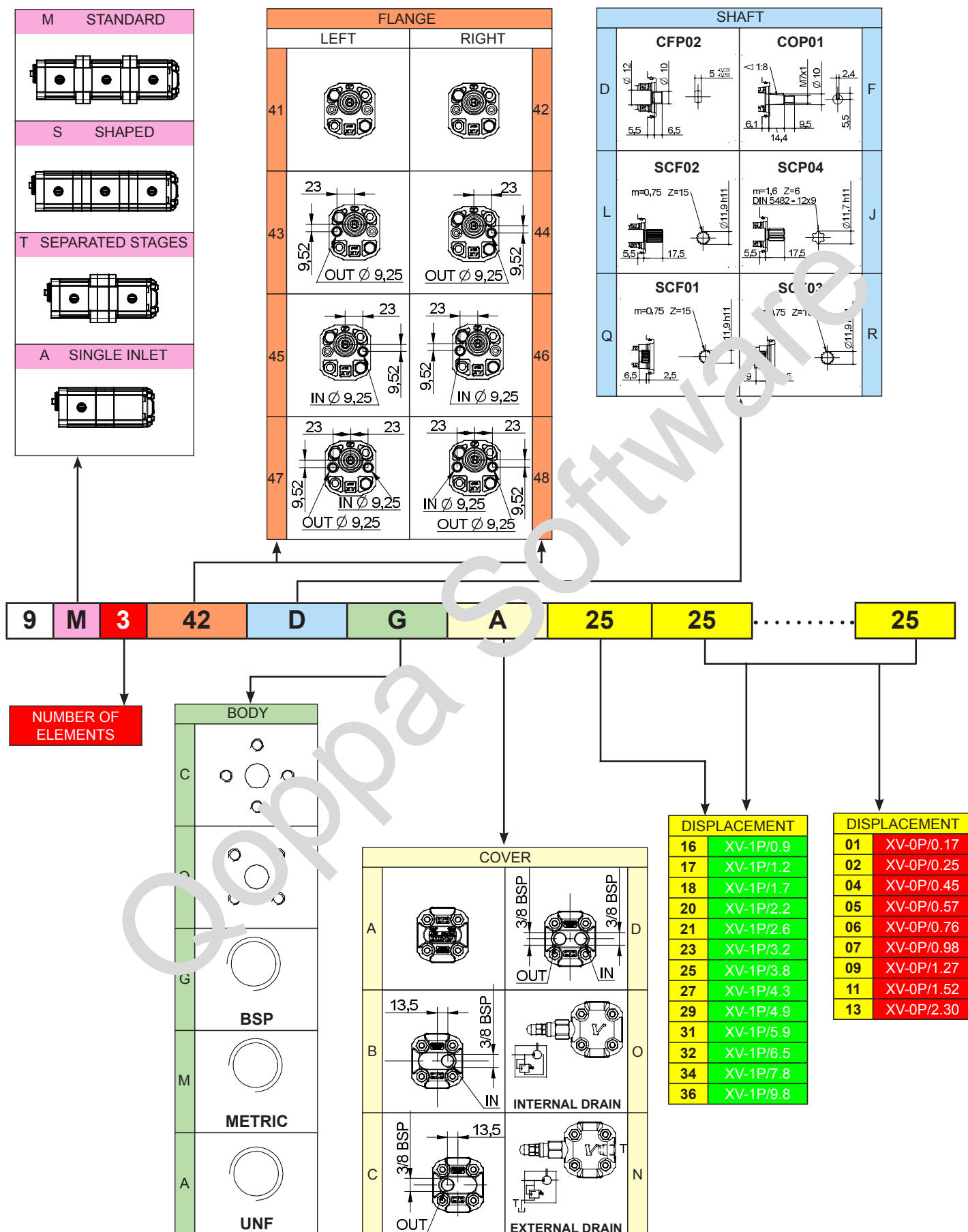

# MULTIPLE PUMP XV-1

XV-1

ø 32 "BH" Body-Shaped FLANGE

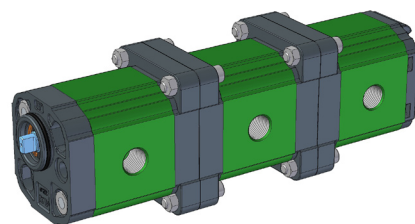
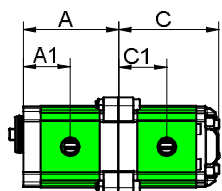
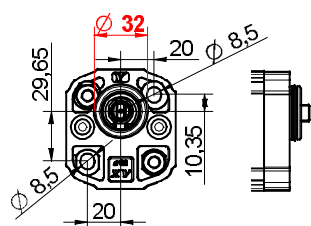

X1T X1F-1

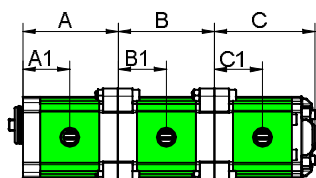

X1T X1I-1 X1F-1

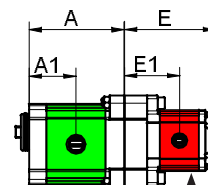

X1T X0-1

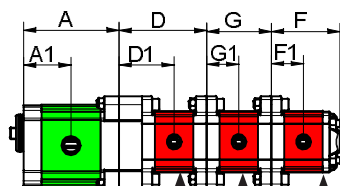

X1T X0I-1 X0I-0 X0F-0

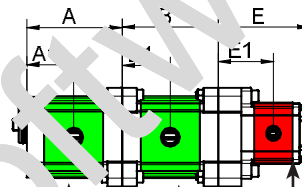

X1T X1I-1 X0F-1

## SEPARATED STAGES

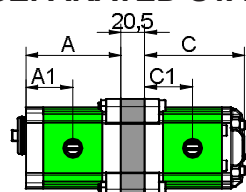

## SINGLE INLET

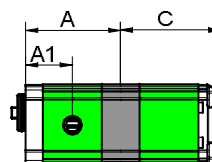

\* = SPECIAL ELEMENT, please contact our customer service for details.

TYPE	Displacement cc/rev	A mm	A1 mm	B mm	B1 mm	C mm	C1 mm	P1 bar	P3 bar	Min speed rpm	Max speed rpm
XV-1 / 0,9	0,91	73,5	66,3	74,5	37,3	78	37,3	240	280	700	6000
XV-1 / 1,2	1,17	74,5	66,8	75,5	37,8	79	37,8	250	290	700	6000
XV-1 / 1,7	1,65	76,5	67,5	77	38,5	80,5	38,5	250	290	700	6000
XV-1 / 2,2	2,18	78,5	68,5	79	39,5	82,5	39,5	250	290	700	6000
XV-1 / 2,6	2,60	80,5	69,5	81	40,5	84,5	40,5	250	300	700	6000
XV-1 / 3,2	3,20	82,5	70,5	83	41,5	86	41,5	250	300	700	6000
XV-1 / 3,8	3,64	84,5	71,5	85	42,5	88,5	42,5	250	300	700	6000
XV-1 / 4,3	4,26	86	72,5	87	43,5	90,5	43,5	250	300	700	6000
XV-1 / 4,9	4,94	89	74	90	45	93,5	45	250	300	700	6000
XV-1 / 5,9	5,85	92,5	76,5	93,5	46,8	97	46,8	250	300	700	5000
XV-1 / 6,5	6,50	95	77,5	96	48	99,5	48	250	300	700	5000
XV-1 / 7,8	7,54	99	79,5	100	50	103,5	50	220	260	700	5000
XV-1 / 9,8	9,88	108	85,5	109	54,5	112,5	54,5	190	230	700	4000

TYPE	Displacement cc/rev	D mm	D1 mm	E mm	E1 mm	F mm	F1 mm	G mm	G1 mm	P1 bar	P3 bar	Min speed rpm	Max speed rpm
XV-0 / 0,17	0,16	72,3	46,2	75,8	46,2	55,8	26,2	52,3	26,2	220	260	700	9000
XV-0 / 0,25	0,24	72,9	46,5	76,4	46,5	56,4	26,5	52,9	26,5	220	260	700	9000
XV-0 / 0,45	0,45	74,5	47,3	78	47,3	58	27,3	54,5	27,3	220	280	700	9000
XV-0 / 0,57	0,56	75,5	47,8	79	47,8	59	27,8	55,5	27,8	220	280	700	9000
XV-0 / 0,76	0,75	77	48,5	80,5	48,5	60,5	28,5	57	28,5	220	280	700	9000
XV-0 / 0,98	0,92	78,5	49,3	82	49,3	62	29,3	58,5	29,3	220	280	700	6000
XV-0 / 1,27	1,26	81	50,5	84,5	50,5	64,5	30,5	61	30,5	220	280	700	6000
XV-0 / 1,52	1,48	83	51,5	86,5	51,5	66,5	31,5	63	31,5	220	280	700	6000
XV-0 / 2,30	2,28	89	54,5	92,5	54,5	72,5	34,5	69	34,5	220	210	700	5000

**MULTIPLE PUMP XV-1**

**XV-1**

**32 "HY" Body-Shaped FLANGE**

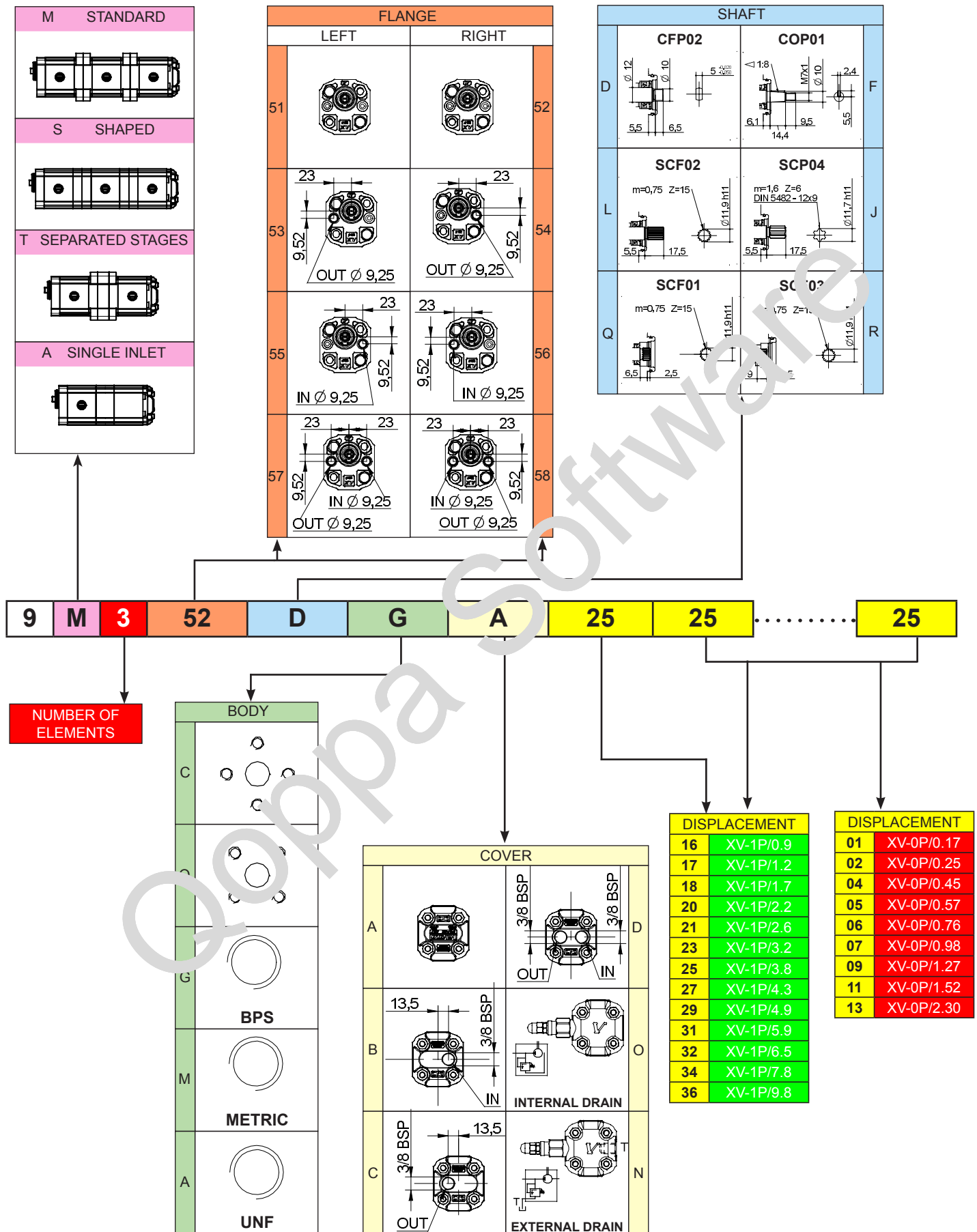

# MULTIPLE PUMP XV-1

## 32 "HY" Body-Shaped FLANGE

XV-1

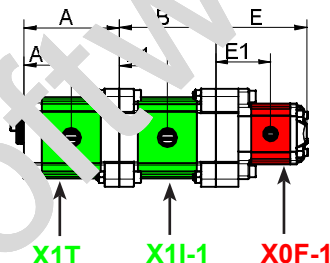
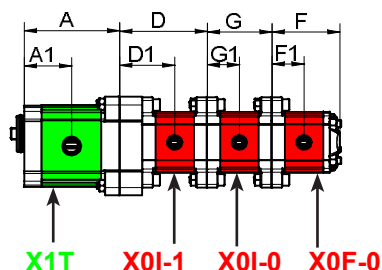
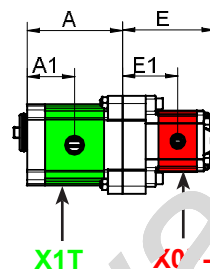
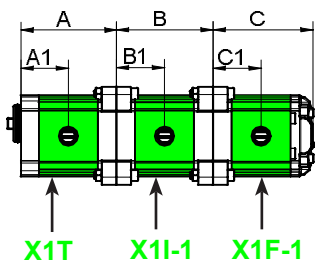
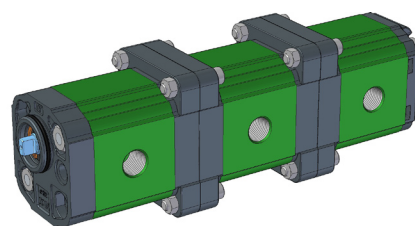
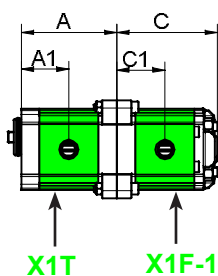
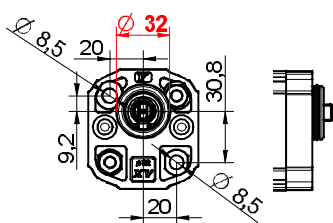

### SEPARATED STAGES

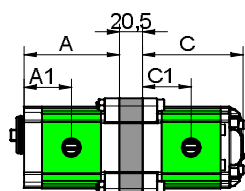

### SINGLE INLET

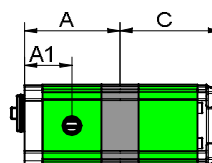

\* = SPECIAL ELEMENT, please contact our customer service for details.

TYPE	Displacement cc/rev	A mm	A1 mm	B mm	B1 mm	C mm	C1 mm	P1 bar	P3 bar	Min speed rpm	Max speed rpm
XV-1 / 0,9	0,91	73,5	36,3	74,5	37,3	78	37,3	240	280	700	6000
XV-1 / 1,2	1,17	74,5	36,8	75,5	37,8	79	37,8	250	290	700	6000
XV-1 / 1,7	1,7	76,5	37,5	77	38,5	80,5	38,5	250	290	700	6000
XV-1 / 2,2	2,28	78,5	38,5	79	39,5	82,5	39,5	250	290	700	6000
XV-1 / 2,6	2,6	80,5	39,5	81	40,5	84,5	40,5	250	300	700	6000
XV-1 / 3,2	3,2	82,5	40,5	83	41,5	86	41,5	250	300	700	6000
XV-1 / 3,8	3,64	84,5	41,5	85	42,5	88,5	42,5	250	300	700	6000
XV-1 / 4,3	4,26	86	42,5	87	43,5	90,5	43,5	250	300	700	6000
XV-1 / 4,9	4,94	89	44	90	45	93,5	45	250	300	700	6000
XV-1 / 5,9	5,85	92,5	45,8	93,5	46,8	97	46,8	250	300	700	5000
XV-1 / 6,5	6,50	95	47	96	48	99,5	48	250	300	700	5000
XV-1 / 7,8	7,54	99	49	100	50	103,5	50	220	260	700	5000
XV-1 / 9,8	9,88	108	53,5	109	54,5	112,5	54,5	190	230	700	4000

TYPE	Displacement cc/rev	D mm	D1 mm	E mm	E1 mm	F mm	F1 mm	G mm	G1 mm	P1 bar	P3 bar	Min speed rpm	Max speed rpm
XV-0 / 0,17	0,16	72,3	46,2	75,8	46,2	55,8	26,2	52,3	26,2	220	260	700	9000
XV-0 / 0,25	0,24	72,9	46,5	76,4	46,5	56,4	26,5	52,9	26,5	220	260	700	9000
XV-0 / 0,45	0,45	74,5	47,3	78	47,3	58	27,3	54,5	27,3	220	280	700	9000
XV-0 / 0,57	0,56	75,5	47,8	79	47,8	59	27,8	55,5	27,8	220	280	700	9000
XV-0 / 0,76	0,75	77	48,5	80,5	48,5	60,5	28,5	57	28,5	220	280	700	9000
XV-0 / 0,98	0,92	78,5	49,3	82	49,3	62	29,3	58,5	29,3	220	280	700	6000
XV-0 / 1,27	1,26	81	50,5	84,5	50,5	64,5	30,5	61	30,5	220	280	700	6000
XV-0 / 1,52	1,48	83	51,5	86,5	51,5	66,5	31,5	63	31,5	220	280	700	6000
XV-0 / 2,30	2,28	89	54,5	92,5	54,5	72,5	34,5	69	34,5	220	210	700	5000

**MULTIPLE PUMP XV-1**  
**32 "BH" Body-Shaped FLANGE GERMAN STANDARD**

**XV-1**

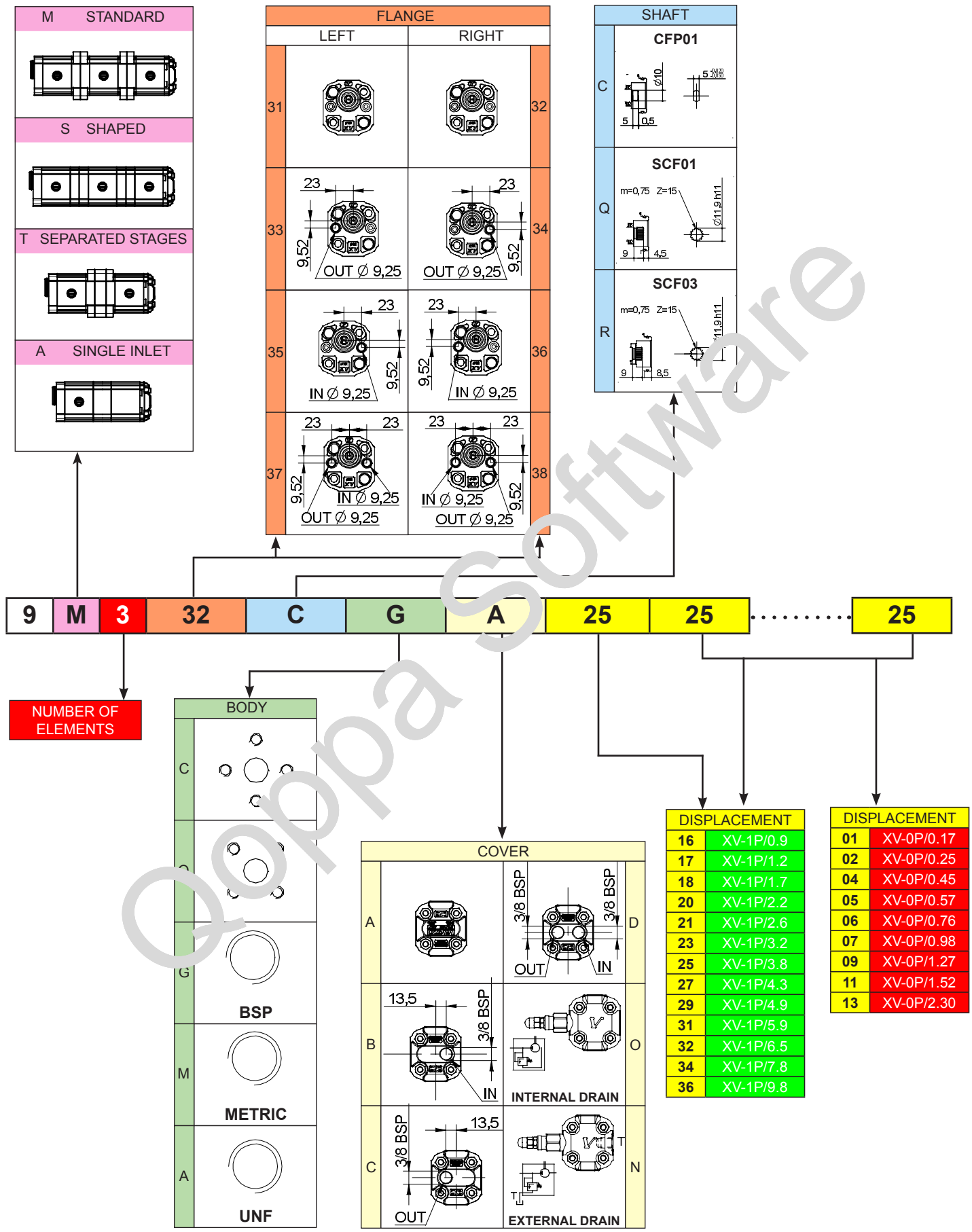

# MULTIPLE PUMP XV-1

XV-1

## 32 "BH" Body-Shaped FLANGE GERMAN STANDARD

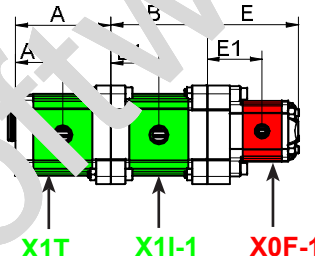
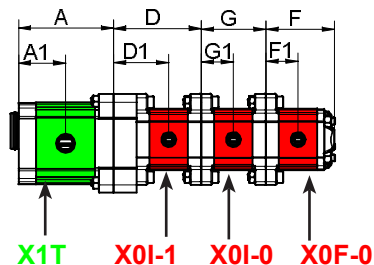
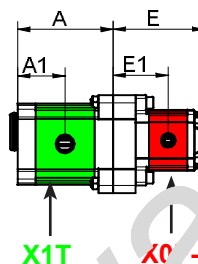
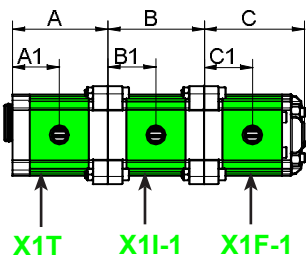
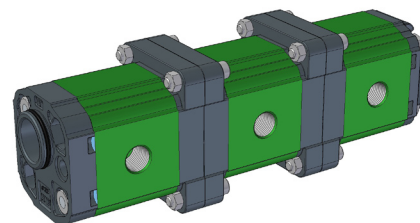
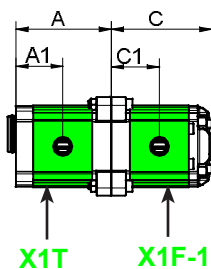
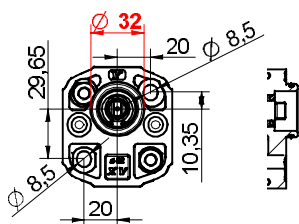

### SEPARATED STAGES

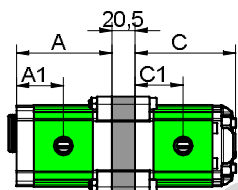

### SINGLE INLET

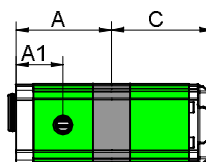

\* = SPECIAL ELEMENT, please contact our customer service for details.

TYPE	Displacement cc/rev	A mm	A1 mm	B mm	B1 mm	C mm	C1 mm	P1 bar	P3 bar	Min speed rpm	Max speed rpm
XV-1 / 0,9	0,91	73,5	36,3	74,5	37,3	78	37,3	240	280	700	6000
XV-1 / 1,2	1,17	74,5	36,8	75,5	37,8	79	37,8	250	290	700	6000
XV-1 / 1,7	1,65	76,5	37,5	77	38,5	80,5	38,5	250	290	700	6000
XV-1 / 2,2	2,18	78,5	38,5	79	39,5	82,5	39,5	250	290	700	6000
XV-1 / 2,6	2,70	80,5	39,5	81	40,5	84,5	40,5	250	300	700	6000
XV-1 / 3,2	3,22	82,5	40,5	83	41,5	86	41,5	250	300	700	6000
XV-1 / 3,8	3,64	84,5	41,5	85	42,5	88,5	42,5	250	300	700	6000
XV-1 / 4,3	4,26	86	42,5	87	43,5	90,5	43,5	250	300	700	6000
XV-1 / 4,9	4,94	89	44	90	45	93,5	45	250	300	700	6000
XV-1 / 5,9	5,85	92,5	45,8	93,5	46,8	97	46,8	250	300	700	5000
XV-1 / 6,5	6,50	95	47	96	48	99,5	48	250	300	700	5000
XV-1 / 7,8	7,54	99	49	100	50	103,5	50	220	260	700	5000
XV-1 / 9,8	9,88	108	53,5	109	54,5	112,5	54,5	190	230	700	4000

TYPE	Displacement cc/rev	D mm	D1 mm	E mm	E1 mm	F mm	F1 mm	G mm	G1 mm	P1 bar	P3 bar	Min speed rpm	Max speed rpm
XV-0 / 0,17	0,16	72,3	46,2	75,8	46,2	55,8	26,2	52,3	26,2	220	260	700	9000
XV-0 / 0,25	0,24	72,9	46,5	76,4	46,5	56,4	26,5	52,9	26,5	220	260	700	9000
XV-0 / 0,45	0,45	74,5	47,3	78	47,3	58	27,3	54,5	27,3	220	280	700	9000
XV-0 / 0,57	0,56	75,5	47,8	79	47,8	59	27,8	55,5	27,8	220	280	700	9000
XV-0 / 0,76	0,75	77	48,5	80,5	48,5	60,5	28,5	57	28,5	220	280	700	9000
XV-0 / 0,98	0,92	78,5	49,3	82	49,3	62	29,3	58,5	29,3	220	280	700	6000
XV-0 / 1,27	1,26	81	50,5	84,5	50,5	64,5	30,5	61	30,5	220	280	700	6000
XV-0 / 1,52	1,48	83	51,5	86,5	51,5	66,5	31,5	63	31,5	220	280	700	6000
XV-0 / 2,30	2,28	89	54,5	92,5	54,5	72,5	34,5	69	34,5	220	210	700	5000

**MULTIPLE PUMP XV-1**  
**ø 50,8 - FLANGE "SAE AA"**

**XV-1**

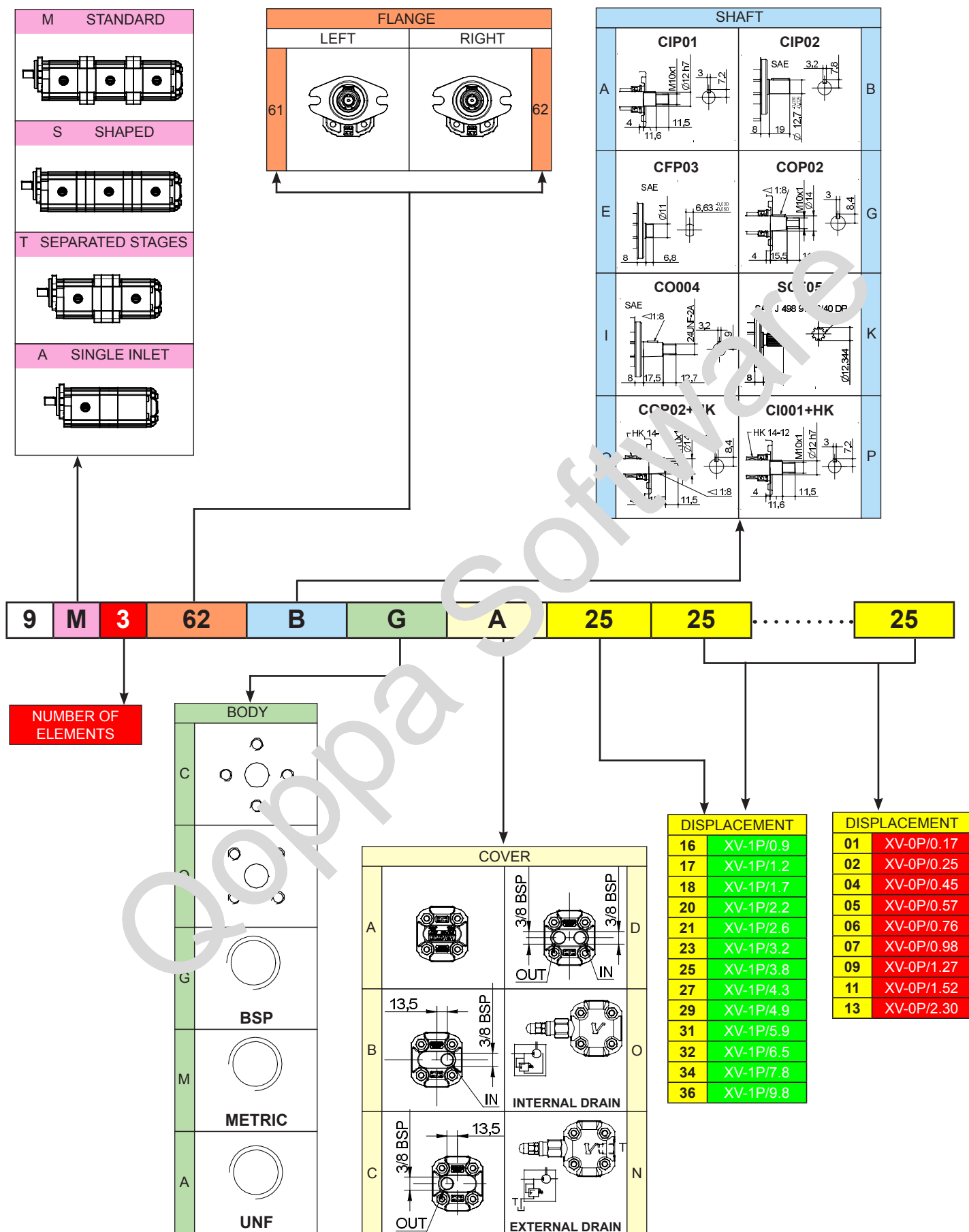

# MULTIPLE PUMP XV-1

Ø 50,8 - FLANGE "SAE AA"

XV-1

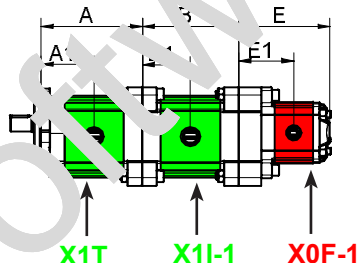
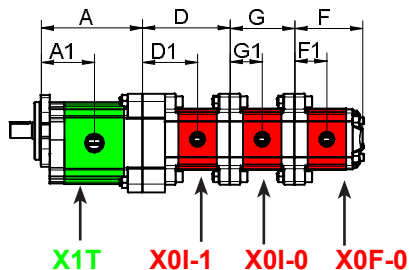
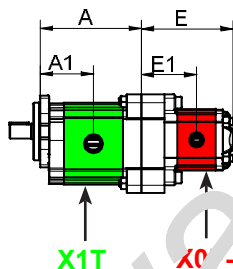
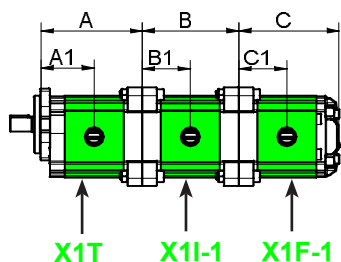
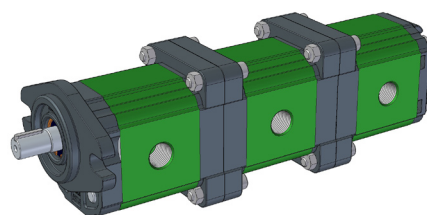
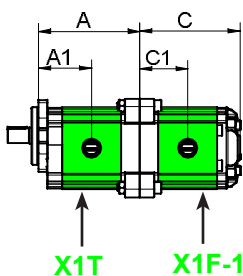
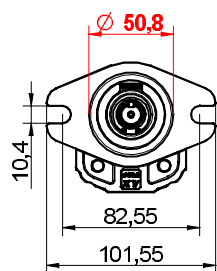

## SEPARATED STAGES

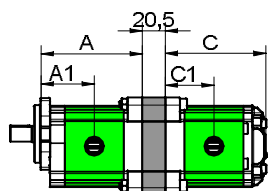

## SINGLE INLET

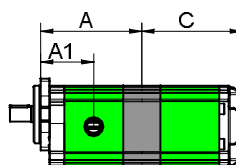

\* = SPECIAL ELEMENT, please contact our customer service for details.

TYPE	Displacement cc/rev	A mm	A1 mm	B mm	B1 mm	C mm	C1 mm	P1 bar	P3 bar	Min speed rpm	Max speed rpm
XV-1 / 0,9	0,91	72,3	46,2	74,5	37,3	78	37,3	240	280	700	6000
XV-1 / 1,2	1,17	80,5	42,3	75,5	37,8	79	37,8	250	290	700	6000
XV-1 / 1,7	1,7	81,5	43	77	38,5	80,5	38,5	250	290	700	6000
XV-1 / 2,2	2,28	82,5	44	79	39,5	82,5	39,5	250	290	700	6000
XV-1 / 2,6	2,6	83,5	45	81	40,5	84,5	40,5	250	300	700	6000
XV-1 / 3,2	3,2	84,5	46	83	41,5	86	41,5	250	300	700	6000
XV-1 / 3,8	3,6	85,5	47	85	42,5	88,5	42,5	250	300	700	6000
XV-1 / 4,3	4,26	86,5	48	87	43,5	90,5	43,5	250	300	700	6000
XV-1 / 4,9	4,94	87,5	49,5	90	45	93,5	45	250	300	700	6000
XV-1 / 5,9	5,85	88,5	51,3	93,5	46,8	97	46,8	250	300	700	5000
XV-1 / 6,5	6,50	89,5	52,5	96	48	99,5	48	250	300	700	5000
XV-1 / 7,8	7,54	90,5	54,5	100	50	103,5	50	220	260	700	5000
XV-1 / 9,8	9,88	91,5	59	109	54,5	112,5	54,5	190	230	700	4000

TYPE	Displacement cc/rev	D mm	D1 mm	E mm	E1 mm	F mm	F1 mm	G mm	G1 mm	P1 bar	P3 bar	Min speed rpm	Max speed rpm
XV-0 / 0,17	0,16	72,3	46,2	75,8	46,2	55,8	26,2	52,3	26,2	220	260	700	9000
XV-0 / 0,25	0,24	72,9	46,5	76,4	46,5	56,4	26,5	52,9	26,5	220	260	700	9000
XV-0 / 0,45	0,45	74,5	47,3	78	47,3	58	27,3	54,5	27,3	220	280	700	9000
XV-0 / 0,57	0,56	75,5	47,8	79	47,8	59	27,8	55,5	27,8	220	280	700	9000
XV-0 / 0,76	0,75	77	48,5	80,5	48,5	60,5	28,5	57	28,5	220	280	700	9000
XV-0 / 0,98	0,92	78,5	49,3	82	49,3	62	29,3	58,5	29,3	220	280	700	6000
XV-0 / 1,27	1,26	81	50,5	84,5	50,5	64,5	30,5	61	30,5	220	280	700	6000
XV-0 / 1,52	1,48	83	51,5	86,5	51,5	66,5	31,5	63	31,5	220	280	700	6000
XV-0 / 2,30	2,28	89	54,5	92,5	54,5	72,5	34,5	69	34,5	220	210	700	5000



# MULTIPLE PUMP XV-2

Ø 36,5 FLANGE

XV-2

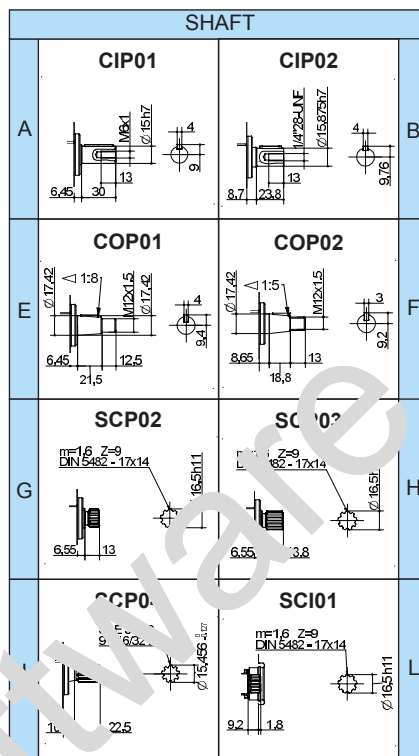
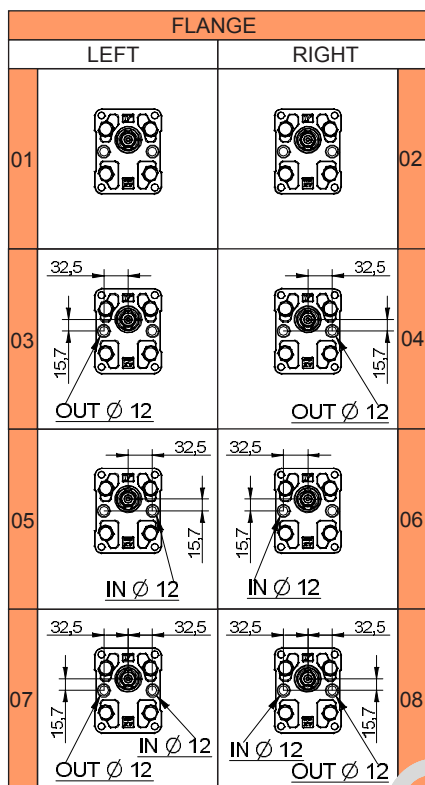
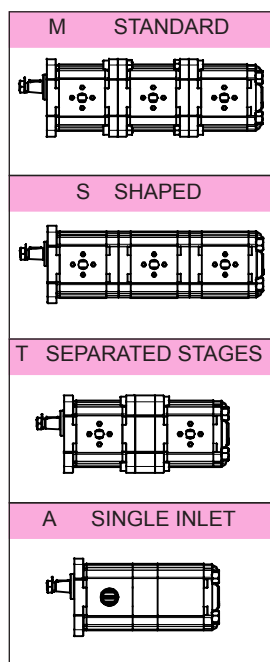

NUMBER OF ELEMENTS

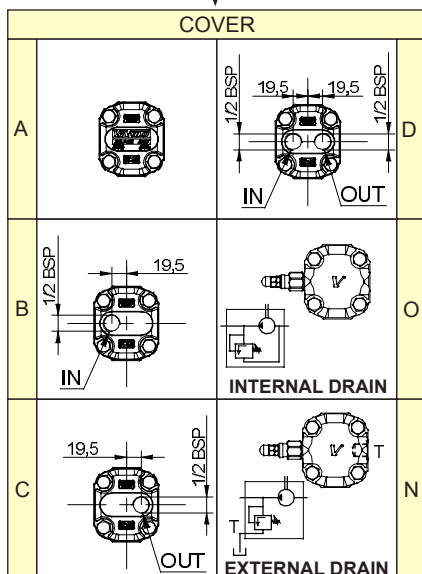
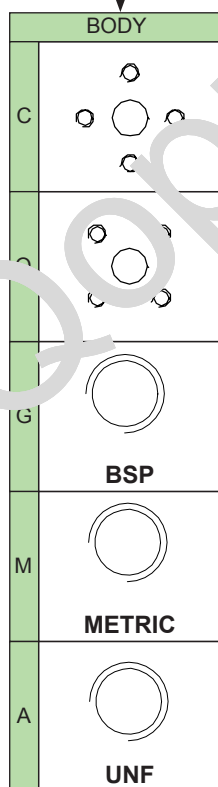

DISPLACEMENT	
41	XV-2P/ 4
43	XV-2P/ 6
45	XV-2P/ 9
47	XV-2P/ 11
49	XV-2P/14
51	XV-2P/17
53	XV-2P/19
55	XV-2P/22
57	XV-2P/26
59	XV-2P/30
61	XV-2P/34
63	XV-2P/40

DISPLACEMENT	
01	XV-0P/0.17
02	XV-0P/0.25
04	XV-0P/0.45
05	XV-0P/0.57
06	XV-0P/0.76
07	XV-0P/0.98
09	XV-0P/1.27
11	XV-0P/1.52
13	XV-0P/2.30
16	XV-1P/0.9
17	XV-1P/1.2
18	XV-1P/1.7
20	XV-1P/2.2
21	XV-1P/2.6
23	XV-1P/3.2
25	XV-1P/3.8
27	XV-1P/4.3
29	XV-1P/4.9
31	XV-1P/5.9
32	XV-1P/6.5
34	XV-1P/7.8
36	XV-1P/9.8

**MULTIPLE PUMP XV-2**

**∅ 36,5 FLANGE**

**XV-2**

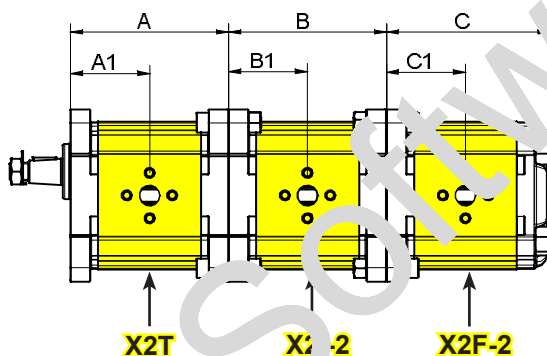
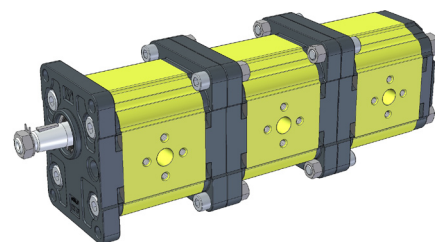
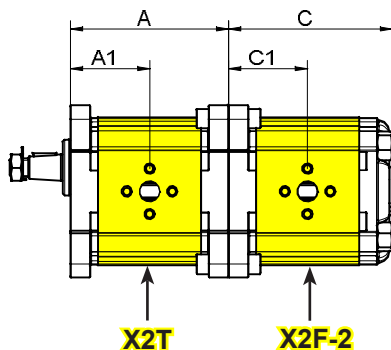
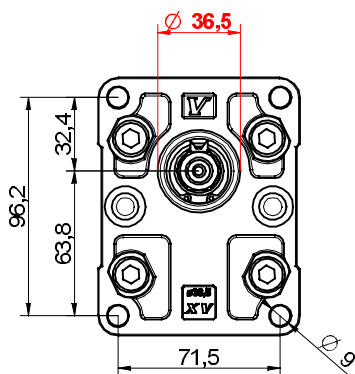

**SEPARATED STAGES**

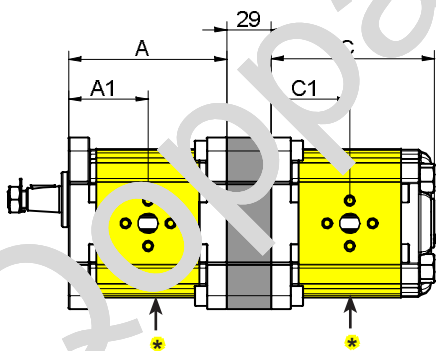

**SINGLE INLET**

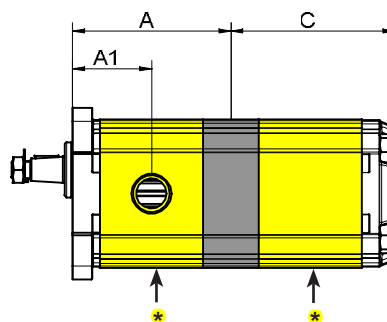

\* = SPECIAL ELEMENT, please contact our customer service for details.

TYPE	Displacement cc/rev	A mm	A1 mm	B mm	B1 mm	C mm	C1 mm	P1 bar	P3 bar	Min speed rpm	Max speed rpm
XV-2 / 4	4,20	83,4	41,7	83,4	41,7	87,2	41,7	260	300	700	4000
XV-2 / 6	6,00	86,4	43,2	86,4	43,2	90,2	43,2	260	300	700	3500
XV-2 / 9	8,40	90,4	45,2	90,4	45,2	94,2	45,2	260	300	700	3500
XV-2 / 11	10,80	94,4	47,2	94,4	47,2	98,2	47,2	260	300	700	3500
XV-2 / 14	14,40	100,4	50,2	100,4	50,2	104,2	50,2	250	290	700	3500
XV-2 / 17	16,80	104,4	52,2	104,4	52,2	108,2	52,2	230	270	700	3500
XV-2 / 19	19,20	108,4	54,2	108,4	54,2	112,2	54,2	210	250	700	3000
XV-2 / 22	22,80	114,4	57,2	114,4	57,2	118,2	57,2	200	240	700	3000
XV-2 / 26	26,20	118,4	59,2	118,4	59,2	122,2	59,2	170	210	700	3000
XV-2 / 30	30,00	126,4	63,2	126,4	63,2	130,2	63,2	160	200	700	2500
XV-2 / 34	34,20	133,4	66,7	133,4	66,7	137,2	66,7	150	190	700	2500
XV-2 / 40	39,60	142,4	71,2	142,4	71,2	146,2	71,2	140	180	700	2000

# MULTIPLE PUMP XV-2

Ø 36,5 FLANGE

XV-2

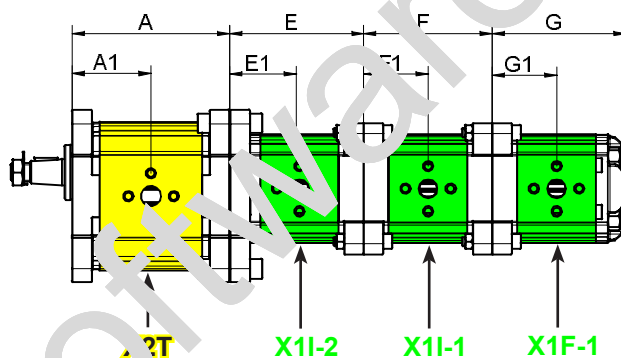
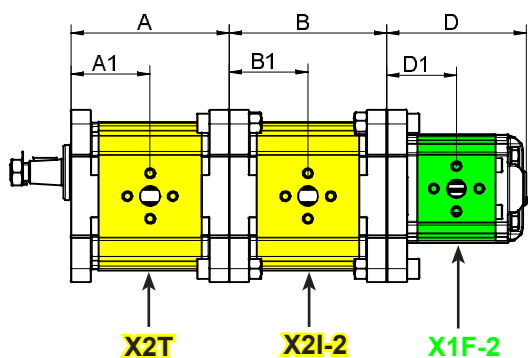
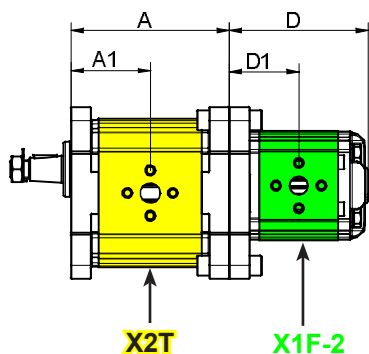
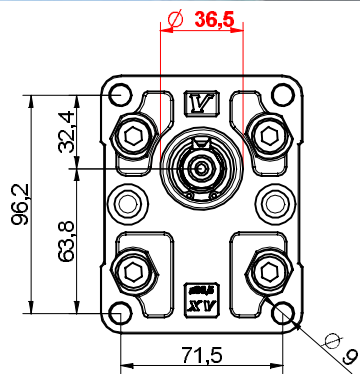

## SEPARATED STAGE

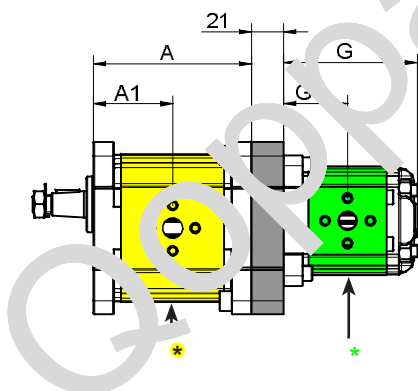

\* = SPECIAL ELEMENT, please contact our customer service for details.

TYPE	Displacement cc/rev	A mm	A1 mm	B mm	B1 mm	C mm	C1 mm	P1 bar	P3 bar	Min speed rpm	Max speed rpm
XV-2 / 4	4,20	83,4	41,7	83,4	41,7	87,2	41,7	260	300	700	4000
XV-2 / 6	6,00	86,4	43,2	86,4	43,2	90,2	43,2	260	300	700	3500
XV-2 / 9	8,40	90,4	45,2	90,4	45,2	94,2	45,2	260	300	700	3500
XV-2 / 11	10,80	94,4	47,2	94,4	47,2	98,2	47,2	260	300	700	3500
XV-2 / 14	14,40	100,4	50,2	100,4	50,2	104,2	50,2	250	290	700	3500
XV-2 / 17	16,80	104,4	52,2	104,4	52,2	108,2	52,2	230	270	700	3500
XV-2 / 19	19,20	108,4	54,2	108,4	54,2	112,2	54,2	210	250	700	3000
XV-2 / 22	22,80	114,4	57,2	114,4	57,2	118,2	57,2	200	240	700	3000
XV-2 / 26	26,20	118,4	59,2	118,4	59,2	122,2	59,2	170	210	700	3000
XV-2 / 30	30,00	126,4	63,2	126,4	63,2	130,2	63,2	160	200	700	2500
XV-2 / 34	34,20	133,4	66,7	133,4	66,7	137,2	66,7	150	190	700	2500
XV-2 / 40	39,60	142,4	71,2	142,4	71,2	146,2	71,2	140	180	700	2000

# MULTIPLE PUMP XV-2

Ø 36,5 FLANGE

XV-2

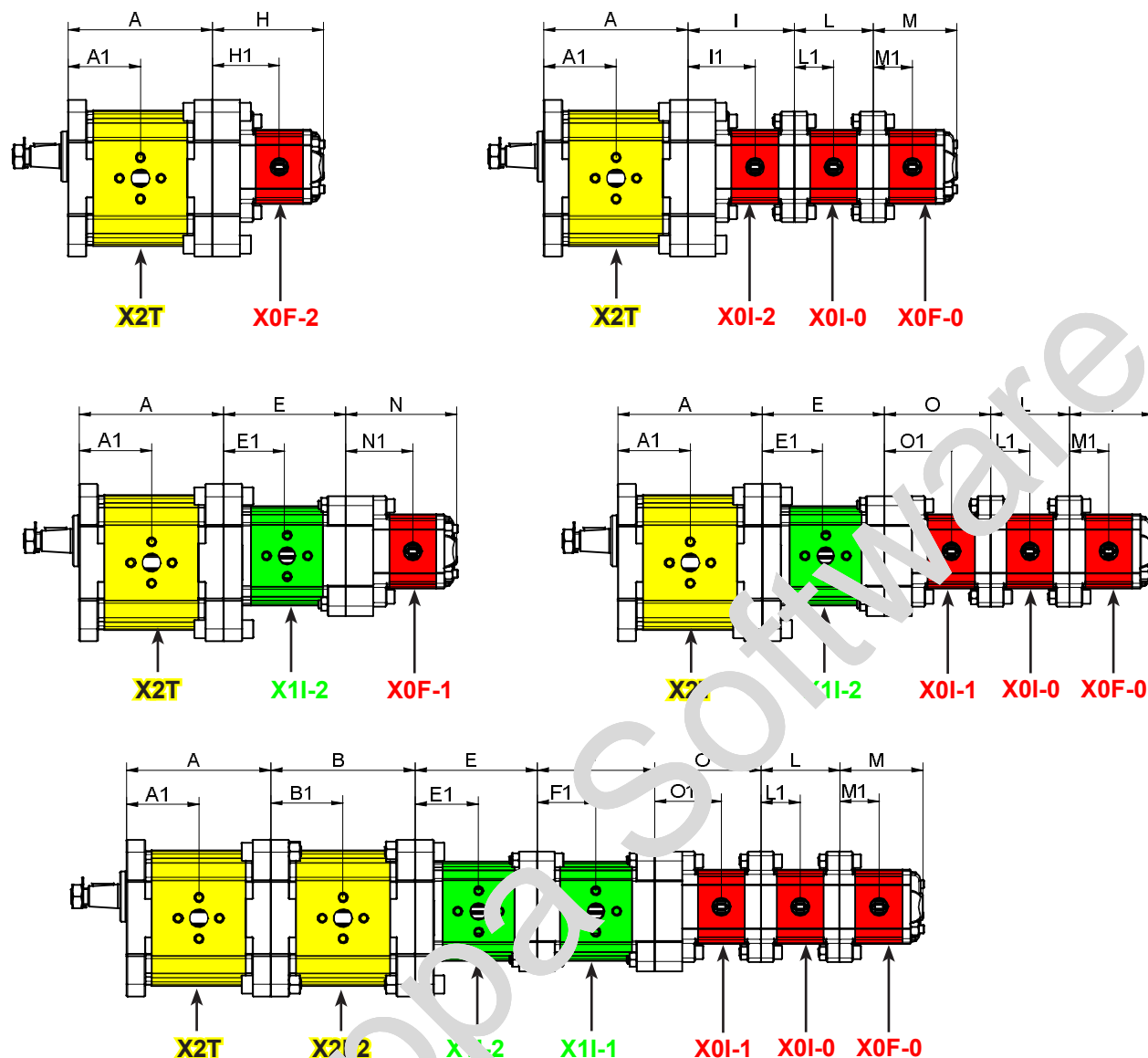

TYPE	Displacement cc/rev	D mm	D1 mm	E mm	E1 mm	F mm	F1 mm	G mm	G1 mm	P1 bar	P3 bar	Min speed rpm	Max speed rpm
XV-1 / 0,9	0,91	81	40	3	40,8	74,5	37,3	78	37,3	240	280	700	6000
XV-1 / 1,2	1,16	81	40	3	40,8	74,5	37,3	78	37,3	240	280	700	6000
XV-1 / 1,7	1,6	81	40	3	40,8	74,5	37,3	78	37,3	240	280	700	6000
XV-1 / 2,2	2,08	81	40	3	40,8	74,5	37,3	78	37,3	240	280	700	6000
XV-1 / 2,6	2,6	81	40	3	40,8	74,5	37,3	78	37,3	240	280	700	6000
XV-1 / 3,2	3,16	81	40	3	40,8	74,5	37,3	78	37,3	240	280	700	6000
XV-1 / 3,8	3,64	81	40	3	40,8	74,5	37,3	78	37,3	240	280	700	6000
XV-1 / 4,3	4,26	81	40	3	40,8	74,5	37,3	78	37,3	240	280	700	6000
XV-1 / 4,9	4,94	81	40	3	40,8	74,5	37,3	78	37,3	240	280	700	6000
XV-1 / 5,9	5,85	100,5	50,3	97	50,3	93,5	46,8	97	46,8	250	300	700	5000
XV-1 / 6,5	6,50	103	51,5	99,5	51,5	96	48	99,5	48	250	300	700	5000
XV-1 / 7,8	7,54	107	53,5	103,5	53,5	100	50	103,5	50	220	260	700	5000
XV-1 / 9,8	9,88	116	58	112,5	58	109	54,5	112,5	54,5	190	230	700	4000

TYPE	Displacem. cc/rev	H mm	H1 mm	I mm	I1 mm	L mm	L1 mm	M mm	M1 mm	N mm	N1 mm	O mm	O1 mm	P1 bar	P3 bar	Min speed rpm	Max speed rpm
XV-0 / 0,17	0,16	75,8	46,2	72,3	46,2	52,3	26,2	55,8	26,2	75,8	46,2	72,3	46,2	220	260	700	9000
XV-0 / 0,25	0,24	76,4	46,5	72,9	46,5	52,9	26,5	56,4	26,5	76,4	46,5	72,9	46,5	220	260	700	9000
XV-0 / 0,45	0,45	78	47,3	74,5	47,3	54,5	27,3	58	27,3	78	47,3	74,5	47,3	220	280	700	9000
XV-0 / 0,57	0,56	79	47,8	75,5	47,8	55,5	27,8	59	27,8	79	47,8	75,5	47,8	220	280	700	9000
XV-0 / 0,76	0,75	80,5	48,5	77	48,5	57	28,5	60,5	28,5	80,5	48,5	77	48,5	220	280	700	9000
XV-0 / 0,98	0,92	82	49,3	78,5	49,3	58,5	29,3	62	29,3	82	49,3	78,5	49,3	220	280	700	6000
XV-0 / 1,27	1,26	84,5	50,5	81	50,5	61	30,5	64,5	30,5	84,5	50,5	81	50,5	220	280	700	6000
XV-0 / 1,52	1,48	86,5	51,5	83	51,5	63	31,5	66,5	31,5	86,5	51,5	83	51,5	220	280	700	6000
XV-0 / 2,30	2,28	92,5	54,5	89	54,5	69	34,5	72,5	34,5	92,5	54,5	89	54,5	220	210	700	5000

## MULTIPLE PUMP XV-2

ø 50 "BH" Body-Shaped FLANGE

### XV-2

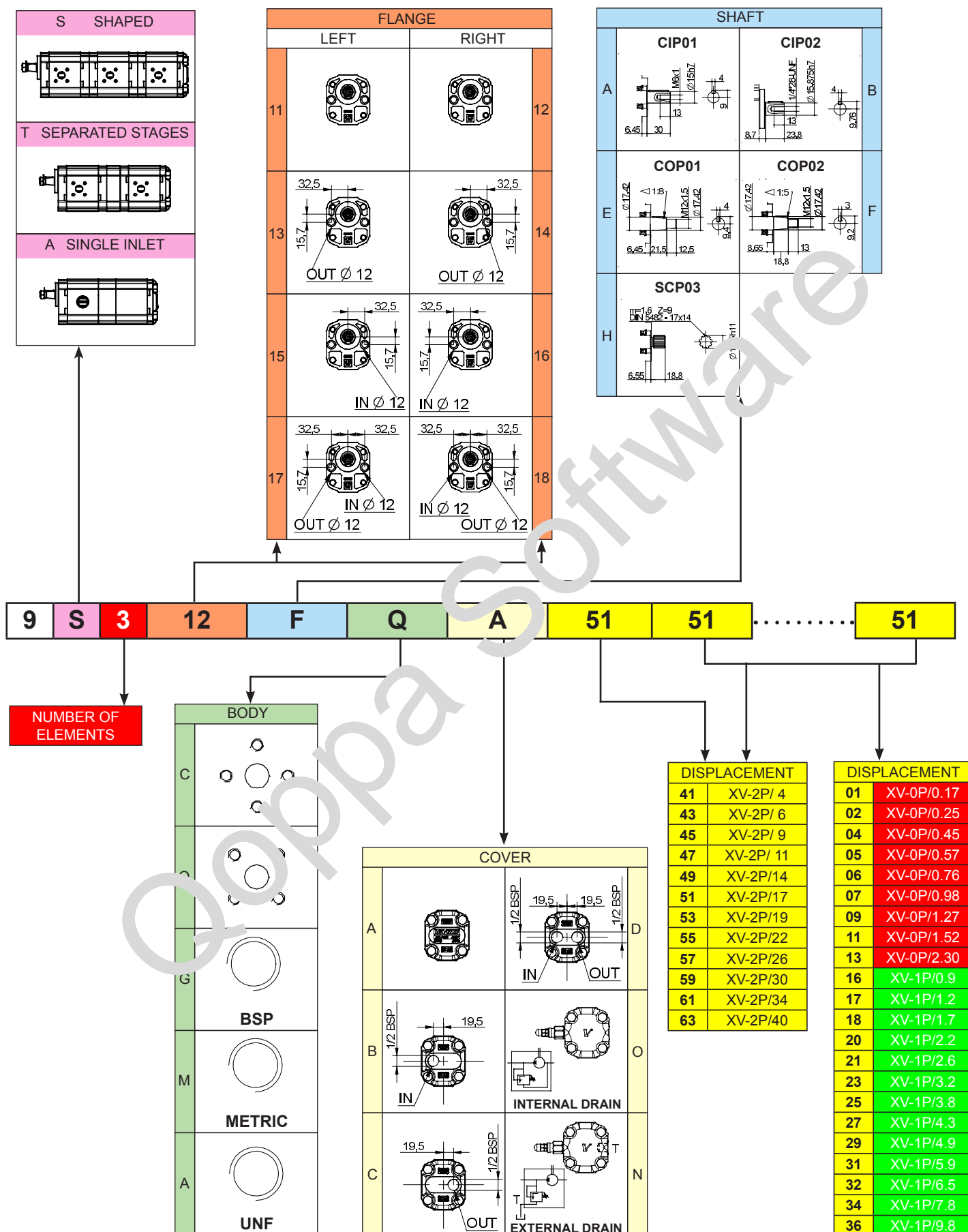

# MULTIPLE PUMP XV-2

**XV-2**

ø 50 "BH" Body-Shaped FLANGE

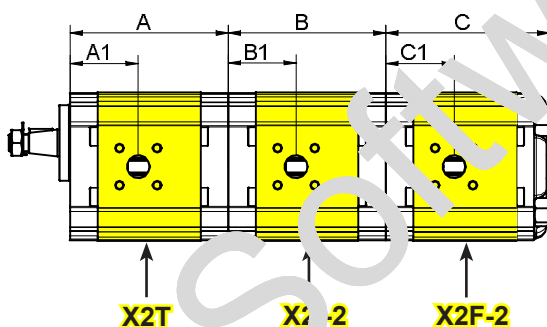
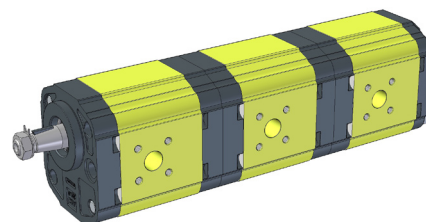
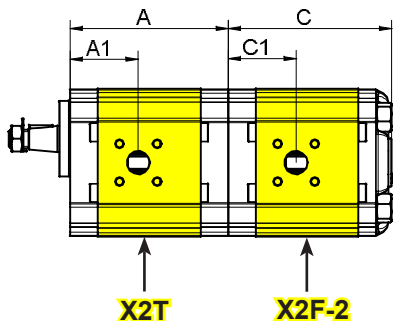
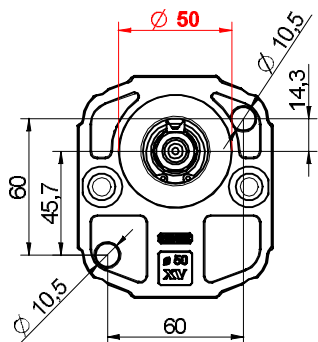

## SEPARATED STAGES

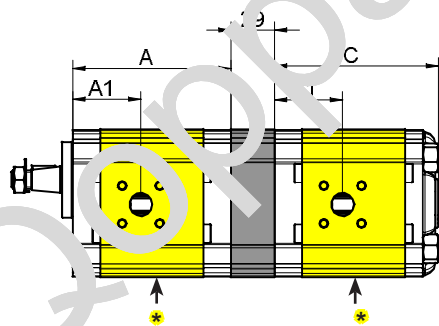

## SINGLE INLET

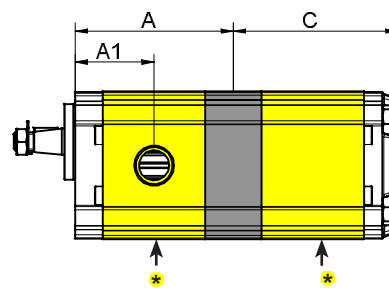

\* = SPECIAL ELEMENT, please contact our customer service for details.

TYPE	Displacement cc/rev	A mm	A1 mm	B mm	B1 mm	C mm	C1 mm	P1 bar	P3 bar	Min speed rpm	Max speed rpm
XV-2 / 4	4,20	83,4	38,6	83,4	38,6	87,2	38,6	260	300	700	4000
XV-2 / 6	6,00	86,4	38,6	86,4	38,6	90,2	38,6	260	300	700	3500
XV-2 / 9	8,40	90,4	40,6	90,4	40,6	94,2	40,6	260	300	700	3500
XV-2 / 11	10,80	94,4	45	94,4	45	98,2	45	260	300	700	3500
XV-2 / 14	14,40	100,4	45	100,4	45	104,2	45	250	290	700	3500
XV-2 / 17	16,80	104,4	45	104,4	45	108,2	45	230	270	700	3500
XV-2 / 19	19,20	108,4	45	108,4	45	112,2	45	210	250	700	3000
XV-2 / 22	22,80	114,4	52,5	114,4	52,5	118,2	52,5	200	240	700	3000
XV-2 / 26	26,20	118,4	52,5	118,4	52,5	122,2	52,5	170	210	700	3000
XV-2 / 30	30,00	126,4	60,7	126,4	60,7	130,2	60,7	160	200	700	2500
XV-2 / 34	34,20	133,4	60,7	133,4	60,7	137,2	60,7	150	190	700	2500
XV-2 / 40	39,60	142,4	60,7	142,4	60,7	146,2	60,7	140	180	700	2000

# MULTIPLE PUMP XV-2

XV-2

Ø 50 "BH" Body-Shaped FLANGE

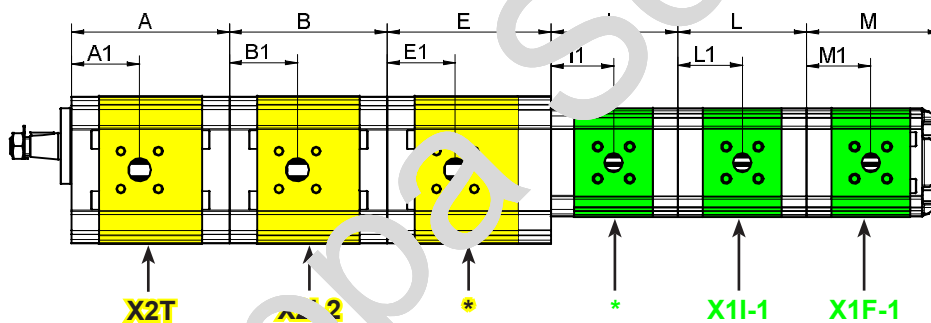
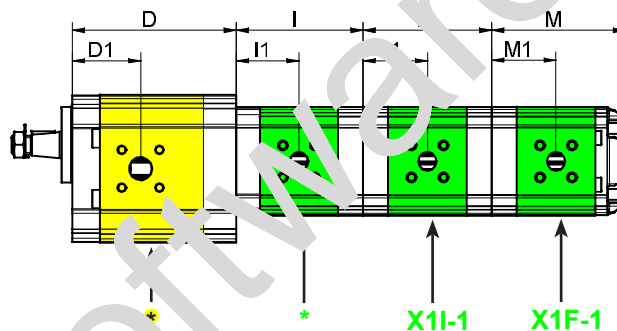
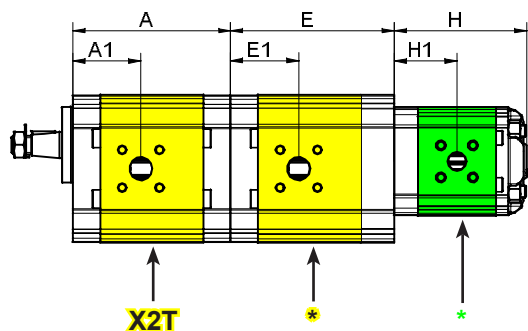
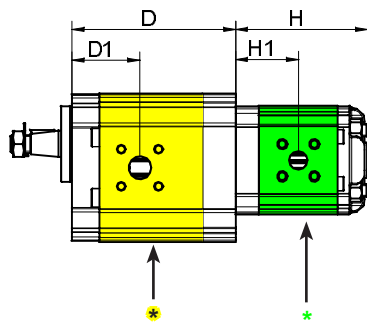
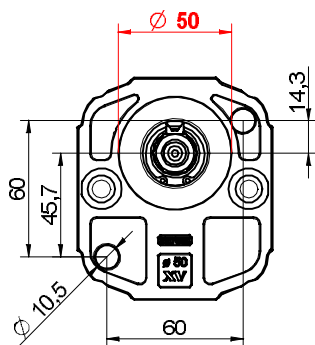

\* = SPECIAL ELEMENT, please contact our customer service for details.

TYPE	Displacem cc/rev	A mm	A1 mm	B mm	B1 mm	C mm	C1 mm	D mm	D1 mm	E mm	E1 mm	F mm	F1 mm	G mm	G1 mm	P1 bar	P3 bar	Min speed rpm	Max speed rpm
XV-2 / 4	4,20	83,4	38,6	83,4	38,6	87,2	38,6	87,2	41,7	87,2	41,7	103,2	41,7	103,2	41,7	260	300	700	4000
XV-2 / 6	6,00	86,4	38,6	86,4	38,6	90,2	38,6	90,2	43,2	90,2	43,2	106,2	43,2	106,2	43,2	260	300	700	3500
XV-2 / 9	8,40	90,4	40,6	90,4	40,6	94,2	40,6	94,2	45,2	94,2	45,2	110,2	45,2	110,2	45,2	260	300	700	3500
XV-2 / 11	10,80	94,4	45	94,4	45	98,2	45	98,2	47,2	98,2	47,2	114,2	47,2	114,2	47,2	260	300	700	3500
XV-2 / 14	14,40	100,4	45	100,4	45	104,2	45	104,2	50,2	104,2	50,2	120,2	50,2	120,2	50,2	250	290	700	3500
XV-2 / 17	16,80	104,4	45	104,4	45	108,2	45	108,2	52,2	108,2	52,2	124,2	52,2	124,2	52,2	230	270	700	3500
XV-2 / 19	19,20	108,4	45	108,4	45	112,2	45	112,2	54,2	112,2	54,2	128,2	54,2	128,2	54,2	210	250	700	3000
XV-2 / 22	22,80	114,4	52,5	114,4	52,5	118,2	52,5	118,2	57,2	118,2	57,2	134,2	57,2	134,2	57,2	200	240	700	3000
XV-2 / 26	26,20	118,4	52,5	118,4	52,5	122,2	52,5	122,2	59,2	122,2	59,2	138,2	59,2	138,2	59,2	170	210	700	3000
XV-2 / 30	30,00	126,4	60,7	126,4	60,7	130,2	60,7	130,2	63,2	130,2	63,2	146,2	63,2	146,2	63,2	160	200	700	2500
XV-2 / 34	34,20	133,4	60,7	133,4	60,7	137,2	60,7	137,2	66,7	137,2	66,7	153,2	66,7	153,2	66,7	150	190	700	2500
XV-2 / 40	39,60	142,4	60,7	142,4	60,7	146,2	60,7	146,2	71,2	146,2	71,2	162,2	71,2	162,2	71,2	140	180	700	2000

# MULTIPLE PUMP XV-2

ø 50 "BH" Body-Shaped FLANGE

XV-2

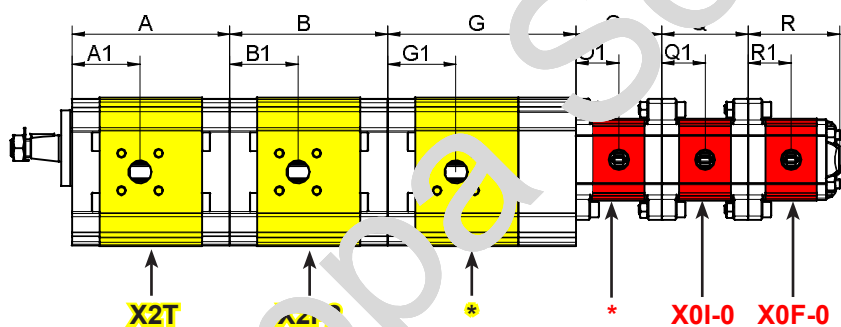
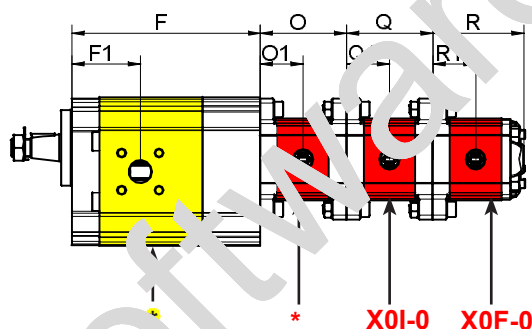
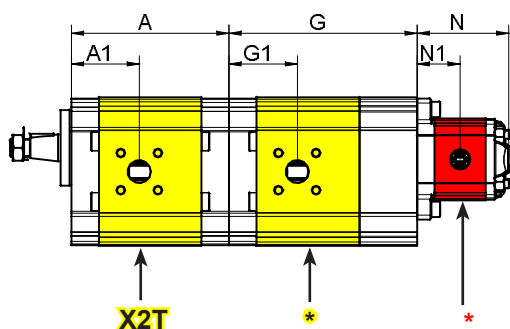
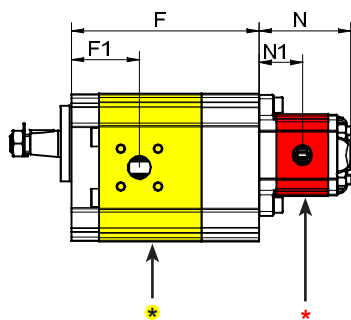

TYPE	Displacement cc/rev	H mm	H1 mm	I mm	I1 mm	L mm	L1 mm	M mm	M1 mm	P1 bar	P3 bar	Min speed rpm	Max speed rpm
XV-1 / 0,9	0,91	77	36,5	74,5	36,3	74,5	37,3	78	37,3	240	280	700	6000
XV-1 / 1,2	1,16	78	36,5	74,5	36,8	75,5	37,8	79	37,8	250	290	700	6000
XV-1 / 1,7	1,6	78,5	37,5	76	37,5	77	38,5	80,5	38,5	250	290	700	6000
XV-1 / 2,2	2,08	81	38,5	78	38,5	79	39,5	82,5	39,5	250	290	700	6000
XV-1 / 2,6	2,6	82	39,5	80	39,5	81	40,5	84,5	40,5	250	300	700	6000
XV-1 / 3,2	3,1	87,5	40,5	82	40,5	83	41,5	86	41,5	250	300	700	6000
XV-1 / 3,8	3,64	87,5	41,5	84	41,5	85	42,5	88,5	42,5	250	300	700	6000
XV-1 / 4,3	4,26	89,5	42,5	86	42,5	87	43,5	90,5	43,5	250	300	700	6000
XV-1 / 4,9	4,94	92,5	44	89	44	90	45	93,5	45	250	300	700	6000
XV-1 / 5,9	5,85	96	45,8	92,5	45,8	93,5	46,8	97	46,8	250	300	700	5000
XV-1 / 6,5	6,50	98,5	47	95	47	96	48	99,5	48	250	300	700	5000
XV-1 / 7,8	7,54	102,5	49	99	49	100	50	103,5	50	220	260	700	5000
XV-1 / 9,8	9,88	111,5	53,5	108	53,5	109	54,5	112,5	54,5	190	230	700	4000

TYPE	Displacem. cc/rev	N mm	N1 mm	O mm	O1 mm	Q mm	Q1 mm	R mm	R1 mm	P1 bar	P3 bar	Min speed rpm	Max speed rpm
XV-0 / 0,17	0,16	55,8	26,2	52,3	26,2	52,3	26,2	55,8	26,2	220	260	700	9000
XV-0 / 0,25	0,24	56,4	26,5	52,9	26,5	52,9	26,5	56,4	26,5	220	260	700	9000
XV-0 / 0,45	0,45	58	27,3	54,5	27,3	54,5	27,3	58	27,3	220	280	700	9000
XV-0 / 0,57	0,56	59	27,8	55,5	27,8	55,5	27,8	59	27,8	220	280	700	9000
XV-0 / 0,76	0,75	60,5	28,5	57	28,5	57	28,5	60,5	28,5	220	280	700	9000
XV-0 / 0,98	0,92	62	29,3	58,5	29,3	58,5	29,3	62	29,3	220	280	700	6000
XV-0 / 1,27	1,26	64,5	30,5	61	30,5	61	30,5	64,5	30,5	220	280	700	6000
XV-0 / 1,52	1,48	66,5	31,5	63	31,5	63	31,5	66,5	31,5	220	280	700	6000
XV-0 / 2,30	2,28	72,5	34,5	69	34,5	69	34,5	72,5	34,5	220	210	700	5000



# MULTIPLE PUMP XV-2

**XV-2**

ø 50 "BH" Body-Shaped FLANGE

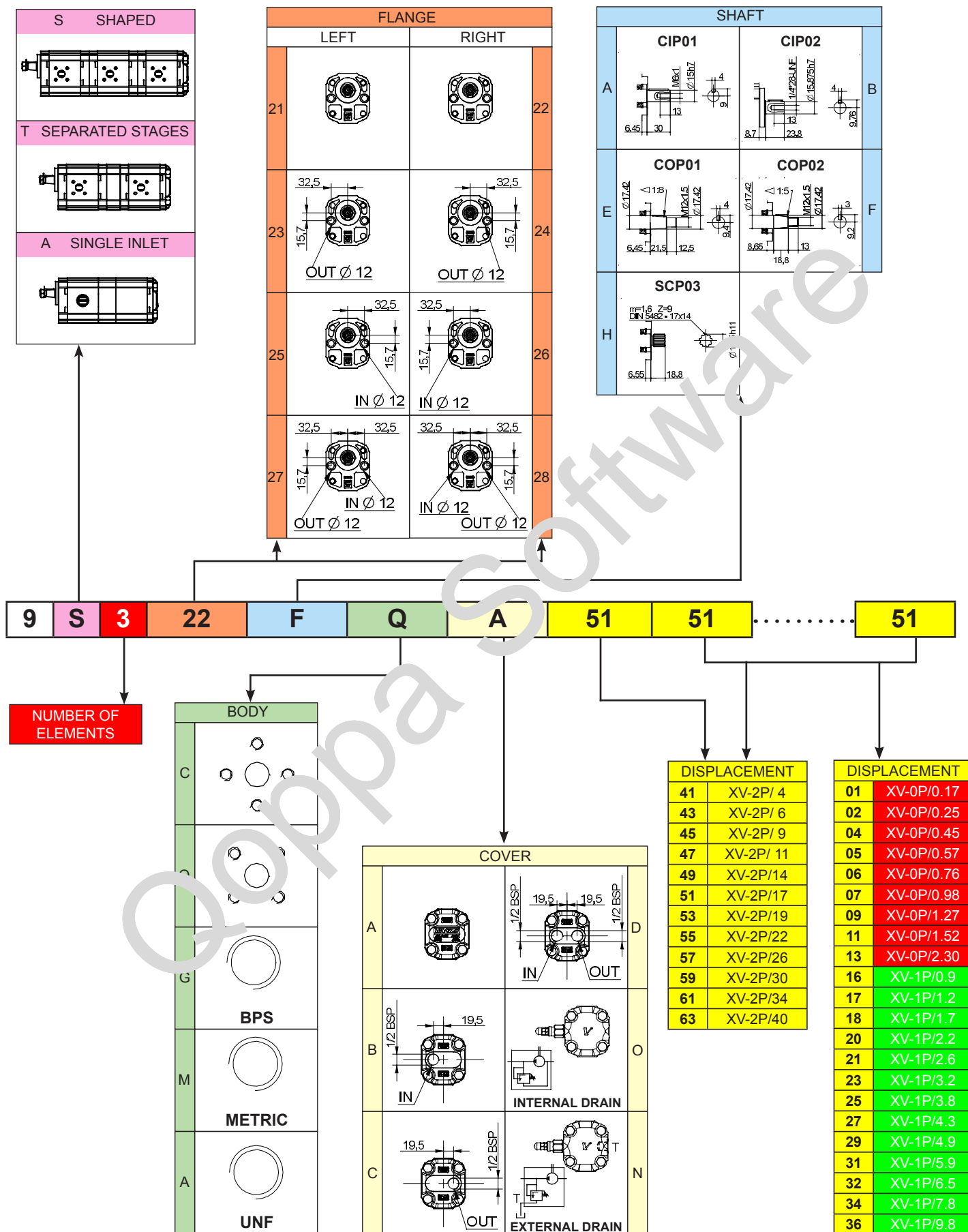

# MULTIPLE PUMP XV-2

**XV-2**

ø 50 "HY" Body-Shaped FLANGE

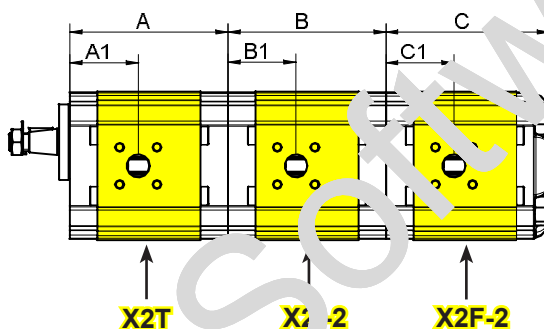
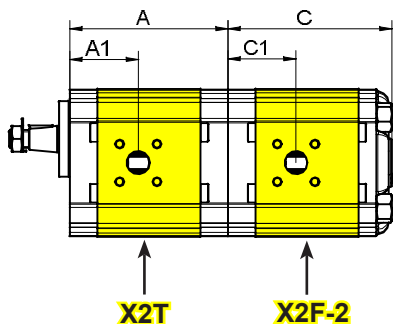
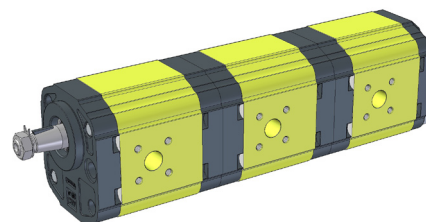
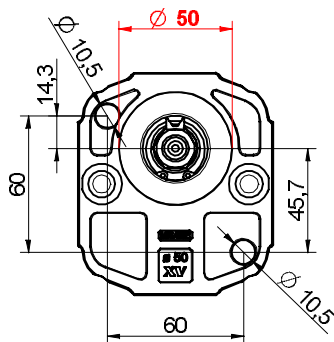

## SEPARATED STAGES

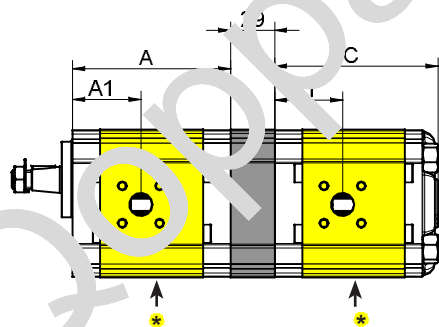

## SINGLE INLET

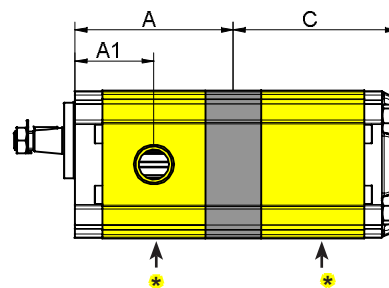

\* = SPECIAL ELEMENT, please contact our customer service for details.

TYPE	Displacement cc/rev	A mm	A1 mm	B mm	B1 mm	C mm	C1 mm	P1 bar	P3 bar	Min speed rpm	Max speed rpm
XV-2 / 4	4,20	83,4	38,6	83,4	38,6	87,2	38,6	260	300	700	4000
XV-2 / 6	6,00	86,4	38,6	86,4	38,6	90,2	38,6	260	300	700	3500
XV-2 / 9	8,40	90,4	40,6	90,4	40,6	94,2	40,6	260	300	700	3500
XV-2 / 11	10,80	94,4	45	94,4	45	98,2	45	260	300	700	3500
XV-2 / 14	14,40	100,4	45	100,4	45	104,2	45	250	290	700	3500
XV-2 / 17	16,80	104,4	45	104,4	45	108,2	45	230	270	700	3500
XV-2 / 19	19,20	108,4	45	108,4	45	112,2	45	210	250	700	3000
XV-2 / 22	22,80	114,4	52,5	114,4	52,5	118,2	52,5	200	240	700	3000
XV-2 / 26	26,20	118,4	52,5	118,4	52,5	122,2	52,5	170	210	700	3000
XV-2 / 30	30,00	126,4	60,7	126,4	60,7	130,2	60,7	160	200	700	2500
XV-2 / 34	34,20	133,4	60,7	133,4	60,7	137,2	60,7	150	190	700	2500
XV-2 / 40	39,60	142,4	60,7	142,4	60,7	146,2	60,7	140	180	700	2000

# MULTIPLE PUMP XV-2

**XV-2**

Ø 50 "HY" Body-Shaped FLANGE

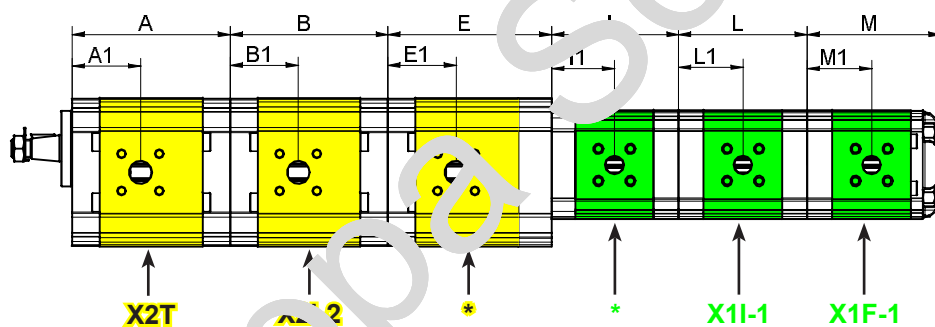
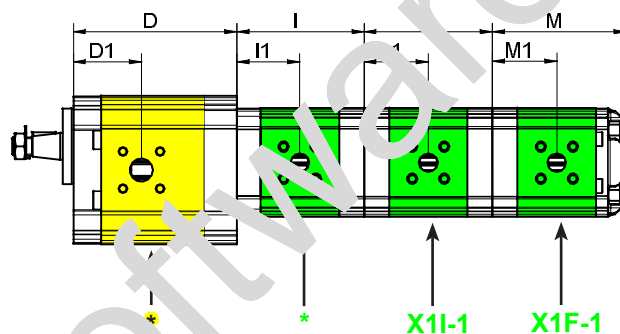
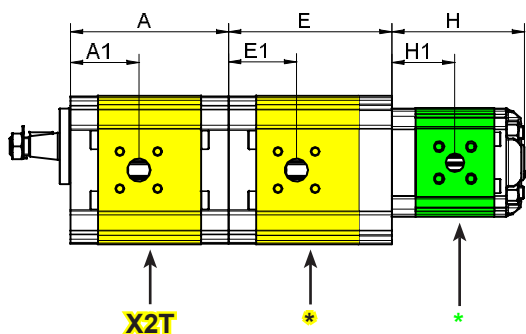
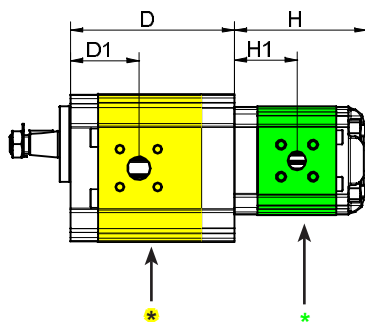
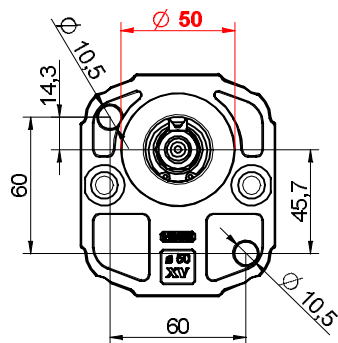

\* = SPECIAL ELEMENT, please contact our customer service for details.

TYPE	Displacem cc/rev	A mm	A1 mm	B mm	B1 mm	C mm	C1 mm	D mm	D1 mm	E mm	E1 mm	F mm	F1 mm	G mm	G1 mm	P1 bar	P3 bar	Min speed rpm	Max speed rpm
XV-2 / 4	4,20	83,4	38,6	83,4	38,6	87,2	38,6	87,2	41,7	87,2	41,7	103,2	41,7	103,2	41,7	260	300	700	4000
XV-2 / 6	6,00	86,4	38,6	86,4	38,6	90,2	38,6	90,2	43,2	90,2	43,2	106,2	43,2	106,2	43,2	260	300	700	3500
XV-2 / 9	8,40	90,4	40,6	90,4	40,6	94,2	40,6	94,2	45,2	94,2	45,2	110,2	45,2	110,2	45,2	260	300	700	3500
XV-2 / 11	10,80	94,4	45	94,4	45	98,2	45	98,2	47,2	98,2	47,2	114,2	47,2	114,2	47,2	260	300	700	3500
XV-2 / 14	14,40	100,4	45	100,4	45	104,2	45	104,2	50,2	104,2	50,2	120,2	50,2	120,2	50,2	250	290	700	3500
XV-2 / 17	16,80	104,4	45	104,4	45	108,2	45	108,2	52,2	108,2	52,2	124,2	52,2	124,2	52,2	230	270	700	3500
XV-2 / 19	19,20	108,4	45	108,4	45	112,2	45	112,2	54,2	112,2	54,2	128,2	54,2	128,2	54,2	210	250	700	3000
XV-2 / 22	22,80	114,4	52,5	114,4	52,5	118,2	52,5	118,2	57,2	118,2	57,2	134,2	57,2	134,2	57,2	200	240	700	3000
XV-2 / 26	26,20	118,4	52,5	118,4	52,5	122,2	52,5	122,2	59,2	122,2	59,2	138,2	59,2	138,2	59,2	170	210	700	3000
XV-2 / 30	30,00	126,4	60,7	126,4	60,7	130,2	60,7	130,2	63,2	130,2	63,2	146,2	63,2	146,2	63,2	160	200	700	2500
XV-2 / 34	34,20	133,4	60,7	133,4	60,7	137,2	60,7	137,2	66,7	137,2	66,7	153,2	66,7	153,2	66,7	150	190	700	2500
XV-2 / 40	39,60	142,4	60,7	142,4	60,7	146,2	60,7	146,2	71,2	146,2	71,2	162,2	71,2	162,2	71,2	140	180	700	2000

# MULTIPLE PUMP XV-2

ø 50 "HY" Body-Shaped FLANGE

XV-2

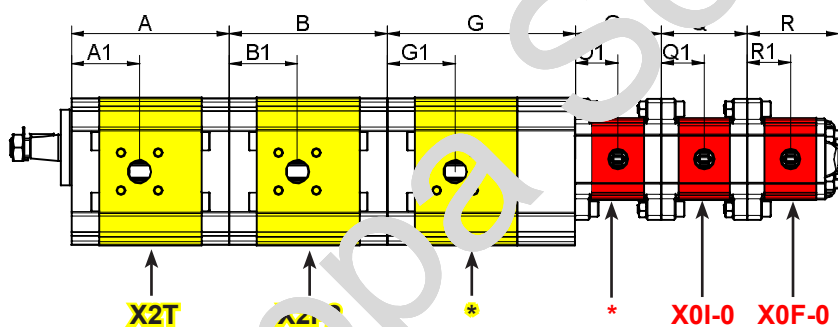
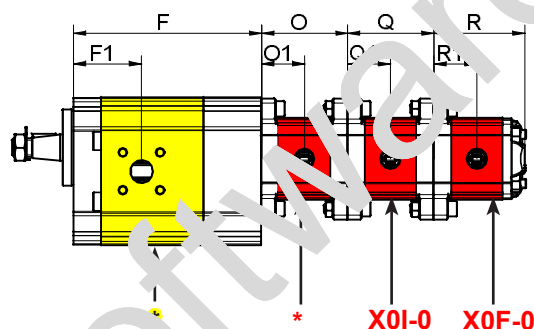
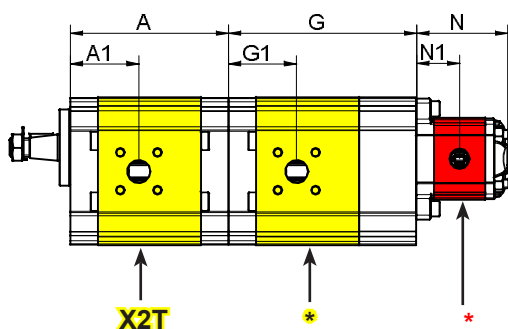
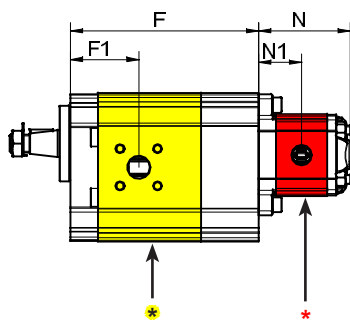

TYPE	Displacement cc/rev	H mm	H1 mm	I mm	I1 mm	L mm	L1 mm	M mm	M1 mm	P1 bar	P3 bar	Min speed rpm	Max speed rpm
XV-1 / 0,9	0,91	77	36,5	72,5	36,3	74,5	37,3	78	37,3	240	280	700	6000
XV-1 / 1,2	1,16	78	36,5	74,5	36,8	75,5	37,8	79	37,8	250	290	700	6000
XV-1 / 1,7	1,6	78,5	37,5	76	37,5	77	38,5	80,5	38,5	250	290	700	6000
XV-1 / 2,2	2,08	81	38,5	78	38,5	79	39,5	82,5	39,5	250	290	700	6000
XV-1 / 2,6	2,6	82	39,5	80	39,5	81	40,5	84,5	40,5	250	300	700	6000
XV-1 / 3,2	3,16	87,5	40,5	82	40,5	83	41,5	86	41,5	250	300	700	6000
XV-1 / 3,8	3,64	87,5	41,5	84	41,5	85	42,5	88,5	42,5	250	300	700	6000
XV-1 / 4,3	4,26	89,5	42,5	86	42,5	87	43,5	90,5	43,5	250	300	700	6000
XV-1 / 4,9	4,94	92,5	44	89	44	90	45	93,5	45	250	300	700	6000
XV-1 / 5,9	5,85	96	45,8	92,5	45,8	93,5	46,8	97	46,8	250	300	700	5000
XV-1 / 6,5	6,50	98,5	47	95	47	96	48	99,5	48	250	300	700	5000
XV-1 / 7,8	7,54	102,5	49	99	49	100	50	103,5	50	220	260	700	5000
XV-1 / 9,8	9,88	111,5	53,5	108	53,5	109	54,5	112,5	54,5	190	230	700	4000

TYPE	Displacem. cc/rev	N mm	N1 mm	O mm	O1 mm	Q mm	Q1 mm	R mm	R1 mm	P1 bar	P3 bar	Min speed rpm	Max speed rpm
XV-0 / 0,17	0,16	55,8	26,2	52,3	26,2	52,3	26,2	55,8	26,2	220	260	700	9000
XV-0 / 0,25	0,24	56,4	26,5	52,9	26,5	52,9	26,5	56,4	26,5	220	260	700	9000
XV-0 / 0,45	0,45	58	27,3	54,5	27,3	54,5	27,3	58	27,3	220	280	700	9000
XV-0 / 0,57	0,56	59	27,8	55,5	27,8	55,5	27,8	59	27,8	220	280	700	9000
XV-0 / 0,76	0,75	60,5	28,5	57	28,5	57	28,5	60,5	28,5	220	280	700	9000
XV-0 / 0,98	0,92	62	29,3	58,5	29,3	58,5	29,3	62	29,3	220	280	700	6000
XV-0 / 1,27	1,26	64,5	30,5	61	30,5	61	30,5	64,5	30,5	220	280	700	6000
XV-0 / 1,52	1,48	66,5	31,5	63	31,5	63	31,5	66,5	31,5	220	280	700	6000
XV-0 / 2,30	2,28	72,5	34,5	69	34,5	69	34,5	72,5	34,5	220	210	700	5000

# MULTIPLE PUMP XV-2

ø 52 - "BH" FLANGE GERMAN STANDARD

**XV-2**

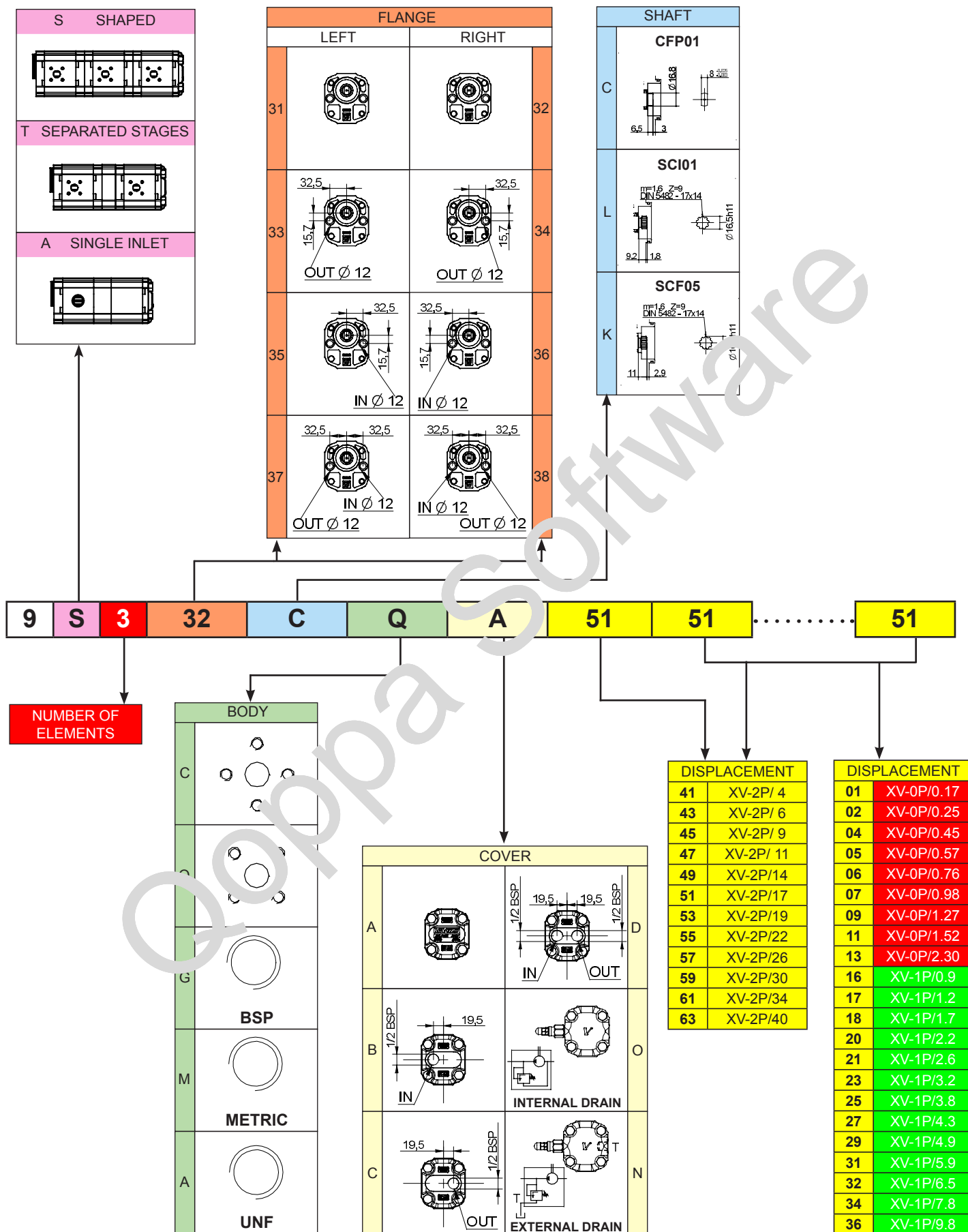

# MULTIPLE PUMP XV-2

**XV-2**

Ø 52 - "BH" FLANGE GERMAN STANDARD

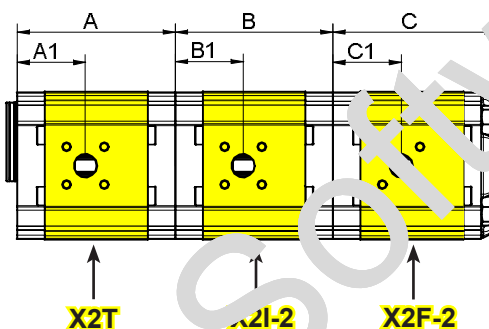
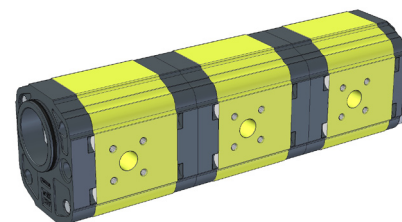
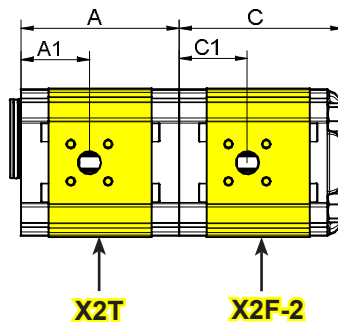
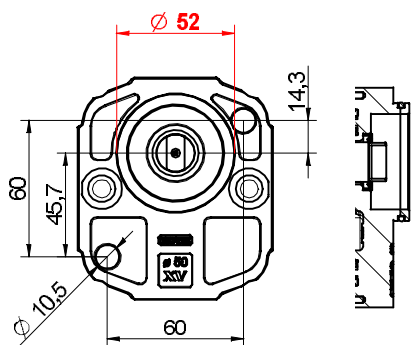

## SEPARATED STAGES

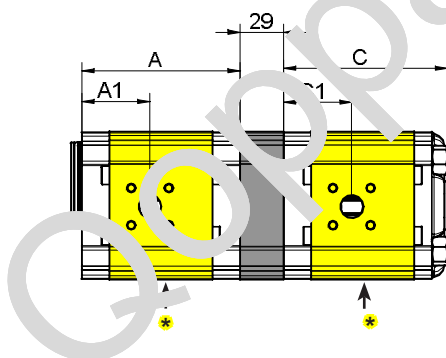

## SINGLE INLET

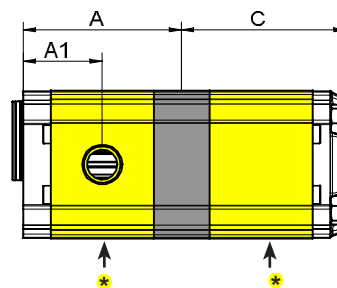

\* = SPECIAL ELEMENT, please contact our customer service for details.

TYPE	Displacement cc/rev	A mm	A1 mm	B mm	B1 mm	C mm	C1 mm	P1 bar	P3 bar	Min speed rpm	Max speed rpm
XV-2 / 4	4,20	83,4	38,6	83,4	38,6	87,2	38,6	260	300	700	4000
XV-2 / 6	6,00	86,4	38,6	86,4	38,6	90,2	38,6	260	300	700	3500
XV-2 / 9	8,40	90,4	40,6	90,4	40,6	94,2	40,6	260	300	700	3500
XV-2 / 11	10,80	94,4	45	94,4	45	98,2	45	260	300	700	3500
XV-2 / 14	14,40	100,4	45	100,4	45	104,2	45	250	290	700	3500
XV-2 / 17	16,80	104,4	45	104,4	45	108,2	45	230	270	700	3500
XV-2 / 19	19,20	108,4	45	108,4	45	112,2	45	210	250	700	3000
XV-2 / 22	22,80	114,4	52,5	114,4	52,5	118,2	52,5	200	240	700	3000
XV-2 / 26	26,20	118,4	52,5	118,4	52,5	122,2	52,5	170	210	700	3000
XV-2 / 30	30,00	126,4	60,7	126,4	60,7	130,2	60,7	160	200	700	2500
XV-2 / 34	34,20	133,4	60,7	133,4	60,7	137,2	60,7	150	190	700	2500
XV-2 / 40	39,60	142,4	60,7	142,4	60,7	146,2	60,7	140	180	700	2000

# MULTIPLE PUMP XV-2

XV-2

Ø 52 - "BH" FLANGE GERMAN STANDARD

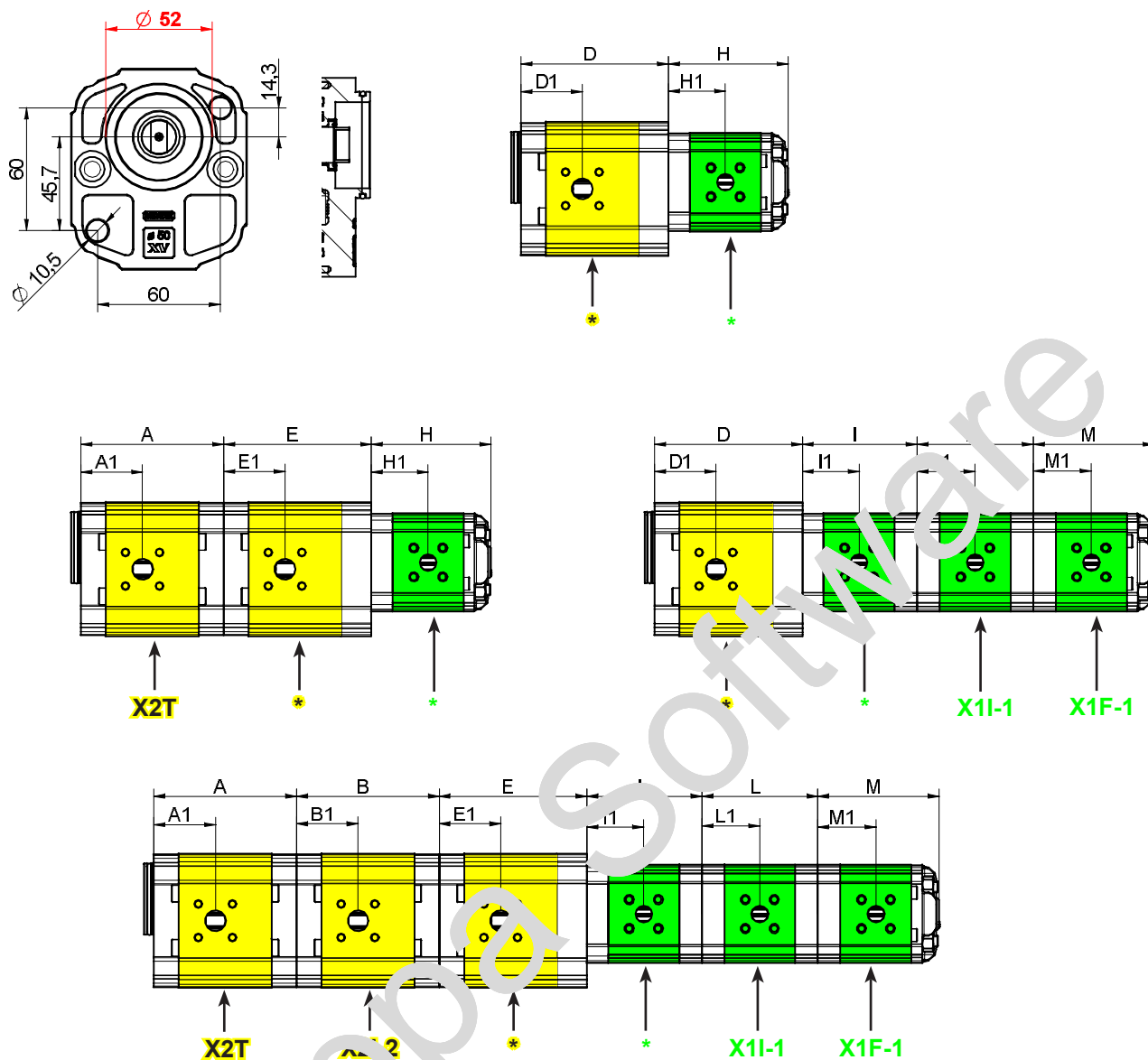

\* = SPECIAL ELEMENT, please contact our customer service for details.

TYPE	Displacem. cc/rev	A mm	A1 mm	B mm	B1 mm	C mm	C1 mm	D mm	D1 mm	E mm	E1 mm	F mm	F1 mm	G mm	G1 mm	P1 bar	P3 bar	Min speed rpm	Max speed rpm
XV-2 / 4	4,20	83,4	38,6	83,4	38,6	87,2	38,6	87,2	41,7	87,2	41,7	103,2	41,7	103,2	41,7	260	300	700	4000
XV-2 / 6	6,00	86,4	38,6	86,4	38,6	90,2	38,6	90,2	43,2	90,2	43,2	106,2	43,2	106,2	43,2	260	300	700	3500
XV-2 / 9	8,40	90,4	40,6	90,4	40,6	94,2	40,6	94,2	45,2	94,2	45,2	110,2	45,2	110,2	45,2	260	300	700	3500
XV-2 / 11	10,80	94,4	45	94,4	45	98,2	45	98,2	47,2	98,2	47,2	114,2	47,2	114,2	47,2	260	300	700	3500
XV-2 / 14	14,40	100,4	45	100,4	45	104,2	45	104,2	50,2	104,2	50,2	120,2	50,2	120,2	50,2	250	290	700	3500
XV-2 / 17	16,80	104,4	45	104,4	45	108,2	45	108,2	52,2	108,2	52,2	124,2	52,2	124,2	52,2	230	270	700	3500
XV-2 / 19	19,20	108,4	45	108,4	45	112,2	45	112,2	54,2	112,2	54,2	128,2	54,2	128,2	54,2	210	250	700	3000
XV-2 / 22	22,80	114,4	52,5	114,4	52,5	118,2	52,5	118,2	57,2	118,2	57,2	134,2	57,2	134,2	57,2	200	240	700	3000
XV-2 / 26	26,20	118,4	52,5	118,4	52,5	122,2	52,5	122,2	59,2	122,2	59,2	138,2	59,2	138,2	59,2	170	210	700	3000
XV-2 / 30	30,00	126,4	60,7	126,4	60,7	130,2	60,7	130,2	63,2	130,2	63,2	146,2	63,2	146,2	63,2	160	200	700	2500
XV-2 / 34	34,20	133,4	60,7	133,4	60,7	137,2	60,7	137,2	66,7	137,2	66,7	153,2	66,7	153,2	66,7	150	190	700	2500
XV-2 / 40	39,60	142,4	60,7	142,4	60,7	146,2	60,7	146,2	71,2	146,2	71,2	162,2	71,2	162,2	71,2	140	180	700	2000

# MULTIPLE PUMP XV-2

**XV-2**

ø 52 - "BH" FLANGE GERMAN STANDARD

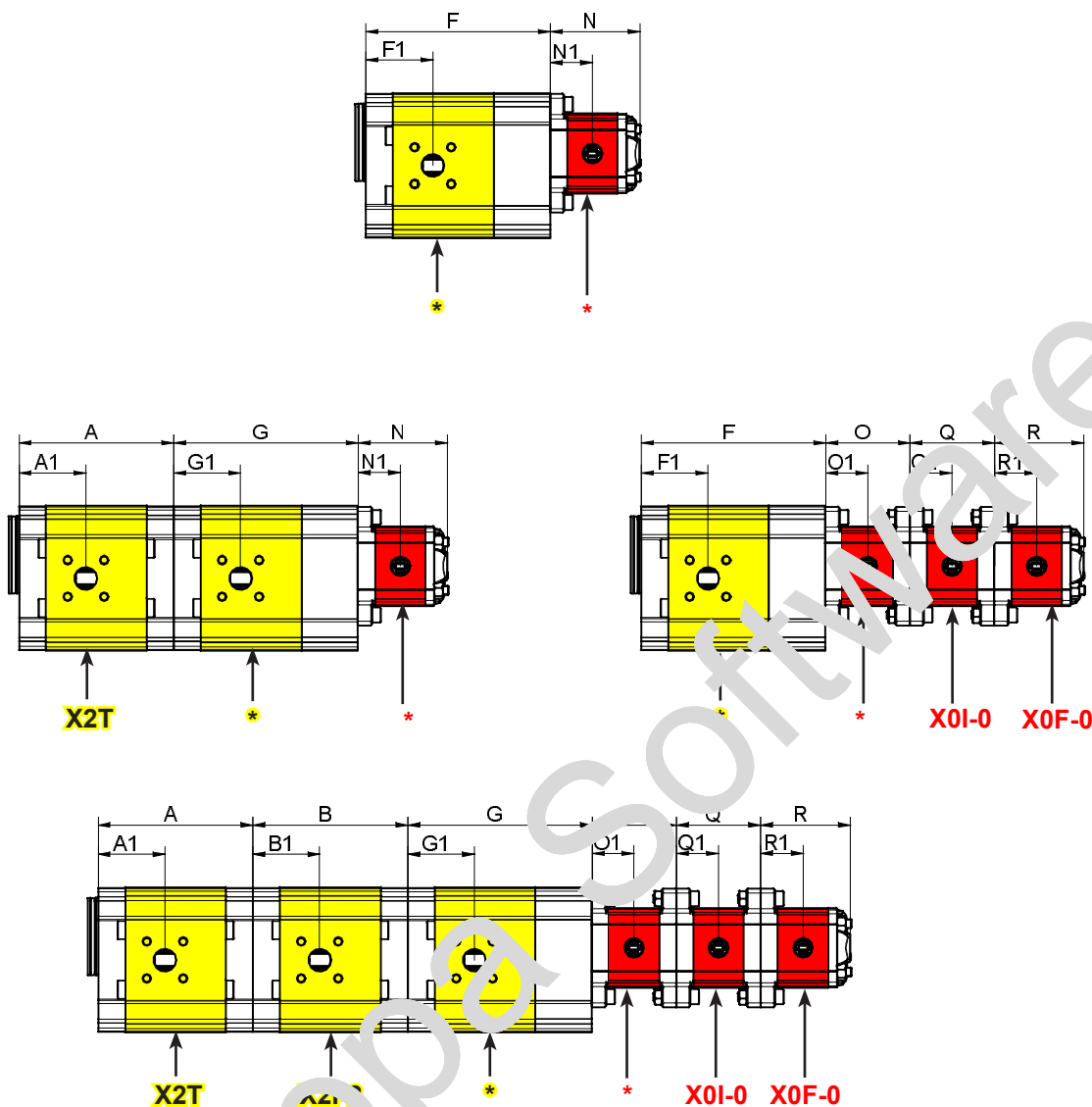

TYPE	Displacement cc/rev	H mm	H1 mm	I mm	I1 mm	L mm	L1 mm	M mm	M1 mm	P1 bar	P3 bar	Min speed rpm	Max speed rpm
XV-1 / 0,9	0,91	77	36,5	74,5	36,3	74,5	37,3	78	37,3	240	280	700	6000
XV-1 / 1,2	1,16	78	36,5	74,5	36,8	75,5	37,8	79	37,8	250	290	700	6000
XV-1 / 1,7	1,6	78	37,5	76	37,5	77	38,5	80,5	38,5	250	290	700	6000
XV-1 / 2,2	2,08	81	38,5	78	38,5	79	39,5	82,5	39,5	250	290	700	6000
XV-1 / 2,6	2,6	82	39,5	80	39,5	81	40,5	84,5	40,5	250	300	700	6000
XV-1 / 3,2	3,1	87,5	40,5	82	40,5	83	41,5	86	41,5	250	300	700	6000
XV-1 / 3,8	3,64	87,5	41,5	84	41,5	85	42,5	88,5	42,5	250	300	700	6000
XV-1 / 4,3	4,26	89,5	42,5	86	42,5	87	43,5	90,5	43,5	250	300	700	6000
XV-1 / 4,9	4,94	92,5	44	89	44	90	45	93,5	45	250	300	700	6000
XV-1 / 5,9	5,85	96	45,8	92,5	45,8	93,5	46,8	97	46,8	250	300	700	5000
XV-1 / 6,5	6,50	98,5	47	95	47	96	48	99,5	48	250	300	700	5000
XV-1 / 7,8	7,54	102,5	49	99	49	100	50	103,5	50	220	260	700	5000
XV-1 / 9,8	9,88	111,5	53,5	108	53,5	109	54,5	112,5	54,5	190	230	700	4000

TYPE	Displacem. cc/rev	N mm	N1 mm	O mm	O1 mm	Q mm	Q1 mm	R mm	R1 mm	P1 bar	P3 bar	Min speed rpm	Max speed rpm
XV-0 / 0,17	0,16	55,8	26,2	52,3	26,2	52,3	26,2	55,8	26,2	220	260	700	9000
XV-0 / 0,25	0,24	56,4	26,5	52,9	26,5	52,9	26,5	56,4	26,5	220	260	700	9000
XV-0 / 0,45	0,45	58	27,3	54,5	27,3	54,5	27,3	58	27,3	220	280	700	9000
XV-0 / 0,57	0,56	59	27,8	55,5	27,8	55,5	27,8	59	27,8	220	280	700	9000
XV-0 / 0,76	0,75	60,5	28,5	57	28,5	57	28,5	60,5	28,5	220	280	700	9000
XV-0 / 0,98	0,92	62	29,3	58,5	29,3	58,5	29,3	62	29,3	220	280	700	6000
XV-0 / 1,27	1,26	64,5	30,5	61	30,5	61	30,5	64,5	30,5	220	280	700	6000
XV-0 / 1,52	1,48	66,5	31,5	63	31,5	63	31,5	66,5	31,5	220	280	700	6000
XV-0 / 2,30	2,28	72,5	34,5	69	34,5	69	34,5	72,5	34,5	220	210	700	5000



# MULTIPLE PUMP XV-2

ø 80 German Standard

**XV-2**

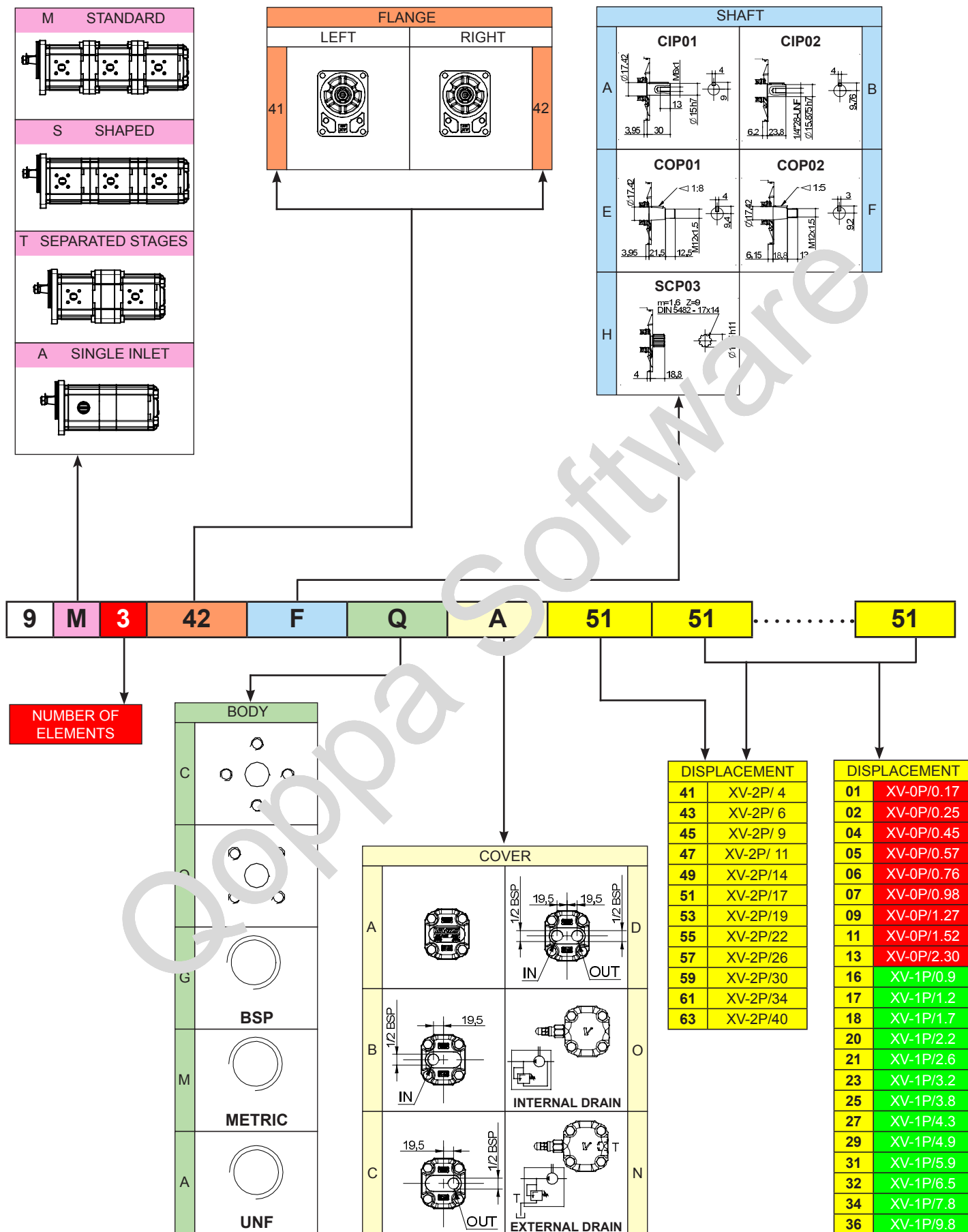

# MULTIPLE PUMP XV-2

Ø 80 GERMAN STANDARD

**XV-2**

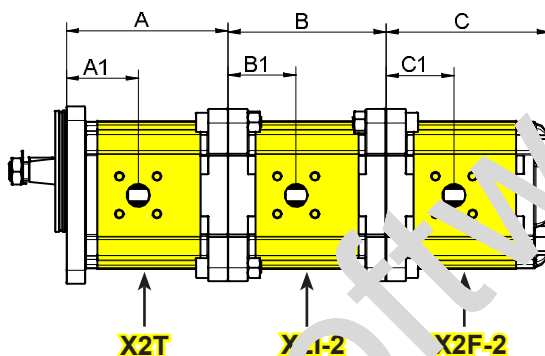
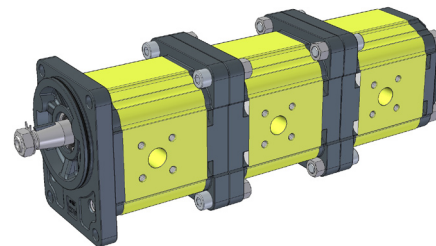
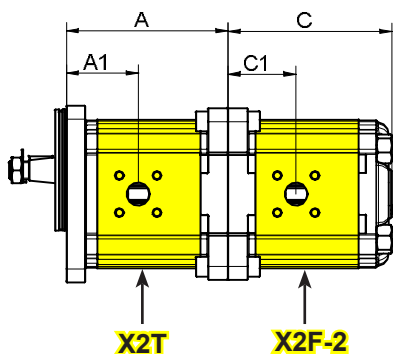
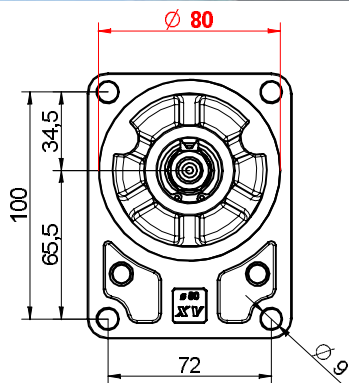

## SEPARATED STAGES

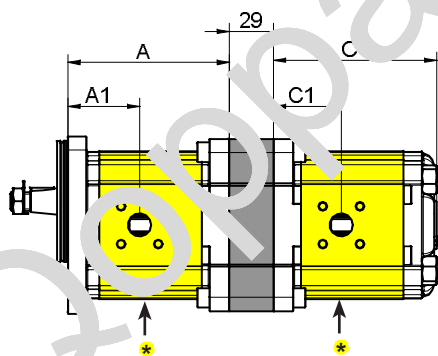

## SINGLE INLET

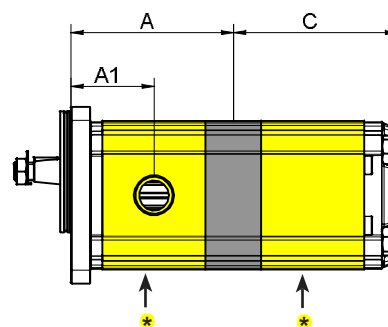

\* = SPECIAL ELEMENT, please contact our customer service for details.

TYPE	Displacem. cc/rev	A mm	A1 mm	B mm	B1 mm	C mm	C1 mm	P1 bar	P3 bar	Min speed rpm	Max speed rpm
XV-2 / 4	4,20	85,9	41,1	83,4	41,7	87,2	41,7	260	300	700	4000
XV-2 / 6	6,00	88,9	41,1	86,4	43,2	90,2	43,2	260	300	700	3500
XV-2 / 9	8,40	92,9	43,1	90,4	45,2	94,2	45,2	260	300	700	3500
XV-2 / 11	10,80	96,9	47,5	94,4	47,2	98,2	47,2	260	300	700	3500
XV-2 / 14	14,40	102,9	47,5	100,4	50,2	104,2	50,2	250	290	700	3500
XV-2 / 17	16,80	106,9	47,5	104,4	52,2	108,2	52,2	230	270	700	3500
XV-2 / 19	19,20	110,9	47,5	108,4	54,2	112,2	54,2	210	250	700	3000
XV-2 / 22	22,80	116,9	55	114,4	57,2	118,2	57,2	200	240	700	3000
XV-2 / 26	26,20	120,9	55	118,4	59,2	122,2	59,2	170	210	700	3000
XV-2 / 30	30,00	128,9	63,2	126,4	63,2	130,2	63,2	160	200	700	2500
XV-2 / 34	34,20	135,9	63,2	133,4	66,7	137,2	66,7	150	190	700	2500
XV-2 / 40	39,60	144,9	63,2	142,4	71,2	146,2	71,2	140	180	700	2000

**MULTIPLE PUMP XV-2**  
**Ø 80 GERMAN STANDARD**

**XV-2**

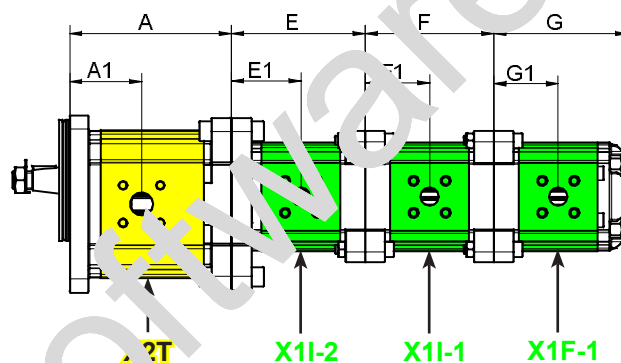
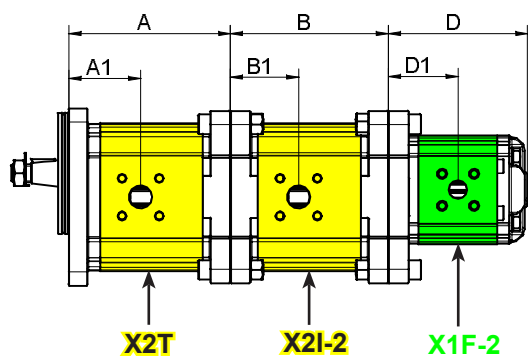
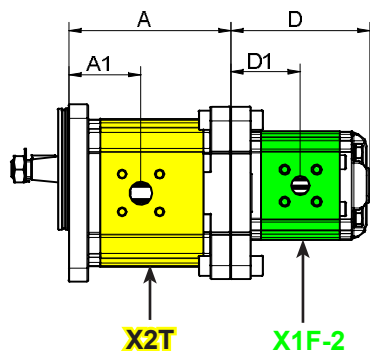
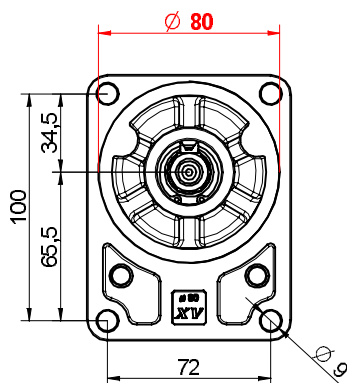

**SEPARATED STAGES**

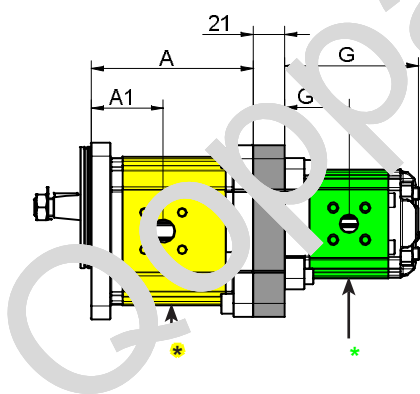

\* = SPECIAL ELEMENT, please contact our customer service for details.

TYPE	Displacem. cc/rev	A mm	A1 mm	B mm	B1 mm	C mm	C1 mm	P1 bar	P3 bar	Min speed rpm	Max speed rpm
XV-2 / 4	4,20	85,9	41,1	83,4	41,7	87,2	41,7	260	300	700	4000
XV-2 / 6	6,00	88,9	41,1	86,4	43,2	90,2	43,2	260	300	700	3500
XV-2 / 9	8,40	92,9	43,1	90,4	45,2	94,2	45,2	260	300	700	3500
XV-2 / 11	10,80	96,9	47,5	94,4	47,2	98,2	47,2	260	300	700	3500
XV-2 / 14	14,40	102,9	47,5	100,4	50,2	104,2	50,2	250	290	700	3500
XV-2 / 17	16,80	106,9	47,5	104,4	52,2	108,2	52,2	230	270	700	3500
XV-2 / 19	19,20	110,9	47,5	108,4	54,2	112,2	54,2	210	250	700	3000
XV-2 / 22	22,80	116,9	55	114,4	57,2	118,2	57,2	200	240	700	3000
XV-2 / 26	26,20	120,9	55	118,4	59,2	122,2	59,2	170	210	700	3000
XV-2 / 30	30,00	128,9	63,2	126,4	63,2	130,2	63,2	160	200	700	2500
XV-2 / 34	34,20	135,9	63,2	133,4	66,7	137,2	66,7	150	190	700	2500
XV-2 / 40	39,60	144,9	63,2	142,4	71,2	146,2	71,2	140	180	700	2000

**MULTIPLE PUMP XV-2**  
**ø 80 GERMAN STANDARD**

**XV-2**

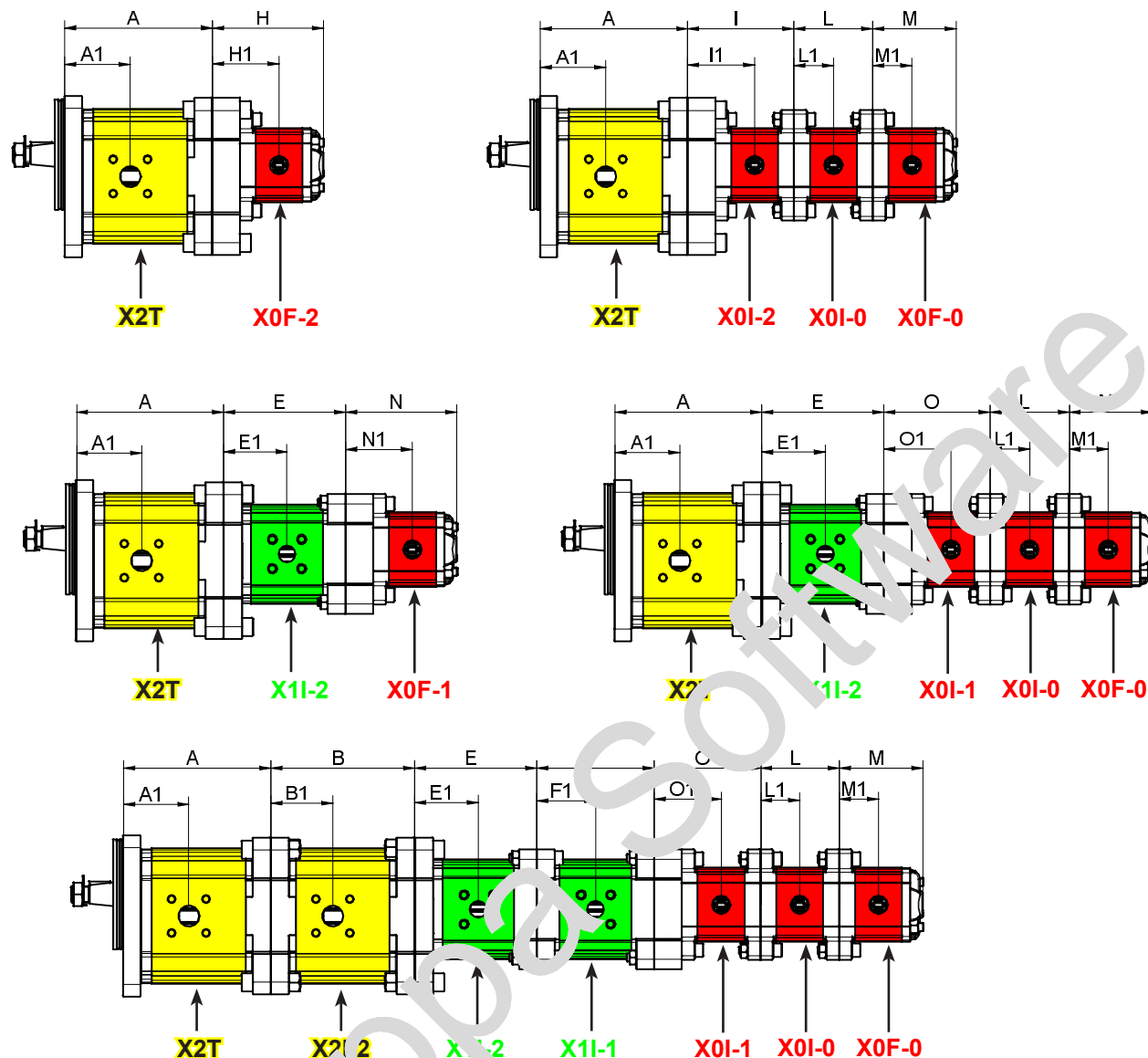

TYPE	Displacem. cc/rev	D mm	D1 mm	E mm	E1 mm	F mm	F1 mm	G mm	G1 mm	P1 bar	P3 bar	Min speed rpm	Max speed rpm
XV-1 / 0,9	0,91	81	40	3	40,8	74,5	37,3	78	37,3	240	280	700	6000
XV-1 / 1,2	1,16	82,5	41	3	41,3	75,5	37,8	79	37,8	250	290	700	6000
XV-1 / 1,7	1,6	84	42	3	42	77	38,5	80,5	38,5	250	290	700	6000
XV-1 / 2,2	2,08	86	43	3	43	79	39,5	82,5	39,5	250	290	700	6000
XV-1 / 2,6	2,6	88	44	3	44	81	40,5	84,5	40,5	250	300	700	6000
XV-1 / 3,2	3,1	90	45	3	45	83	41,5	86	41,5	250	300	700	6000
XV-1 / 3,8	3,64	92	46	3	46	85	42,5	88,5	42,5	250	300	700	6000
XV-1 / 4,3	4,26	94	47	3	47	87	43,5	90,5	43,5	250	300	700	6000
XV-1 / 4,9	4,94	97	48,5	3	48,5	90	45	93,5	45	250	300	700	6000
XV-1 / 5,9	5,85	100,5	50,3	3	50,3	93,5	46,8	97	46,8	250	300	700	5000
XV-1 / 6,5	6,50	103	51,5	3	51,5	96	48	99,5	48	250	300	700	5000
XV-1 / 7,8	7,54	107	53,5	3	53,5	100	50	103,5	50	220	260	700	5000
XV-1 / 9,8	9,88	116	58	3	58	109	54,5	112,5	54,5	190	230	700	4000

TYPE	Displacem. cc/rev	H mm	H1 mm	I mm	I1 mm	L mm	L1 mm	M mm	M1 mm	N mm	N1 mm	O mm	O1 mm	P1 bar	P3 bar	Min speed rpm	Max speed rpm
XV-0 / 0,17	0,16	75,8	46,2	72,3	46,2	52,3	26,2	55,8	26,2	75,8	46,2	72,3	46,2	220	260	700	9000
XV-0 / 0,25	0,24	76,4	46,5	72,9	46,5	52,9	26,5	56,4	26,5	76,4	46,5	72,9	46,5	220	260	700	9000
XV-0 / 0,45	0,45	78	47,3	74,5	47,3	54,5	27,3	58	27,3	78	47,3	74,5	47,3	220	280	700	9000
XV-0 / 0,57	0,56	79	47,8	75,5	47,8	55,5	27,8	59	27,8	79	47,8	75,5	47,8	220	280	700	9000
XV-0 / 0,76	0,75	80,5	48,5	77	48,5	57	28,5	60,5	28,5	80,5	48,5	77	48,5	220	280	700	9000
XV-0 / 0,98	0,92	82	49,3	78,5	49,3	58,5	29,3	62	29,3	82	49,3	78,5	49,3	220	280	700	6000
XV-0 / 1,27	1,26	84,5	50,5	81	50,5	61	30,5	64,5	30,5	84,5	50,5	81	50,5	220	280	700	6000
XV-0 / 1,52	1,48	86,5	51,5	83	51,5	63	31,5	66,5	31,5	86,5	51,5	83	51,5	220	280	700	6000
XV-0 / 2,30	2,28	92,5	54,5	89	54,5	69	34,5	72,5	34,5	92,5	54,5	89	54,5	220	210	700	5000

# MULTIPLE PUMP XV-2

Ø 82,5 - FLANGE "SAE A"

XV-2

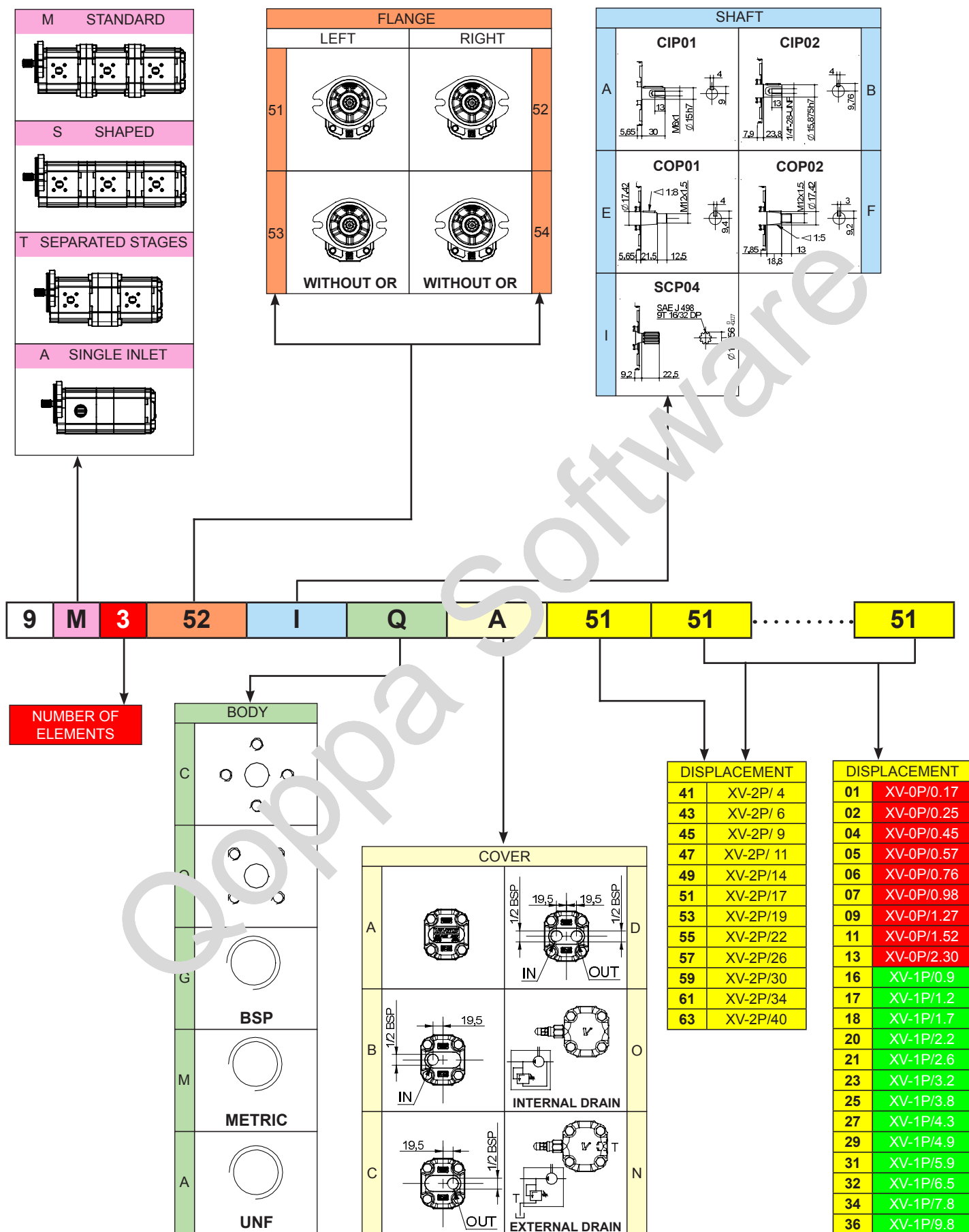

# MULTIPLE PUMP XV-2

Ø 82,5 - FLANGE "SAE A"

XV-2

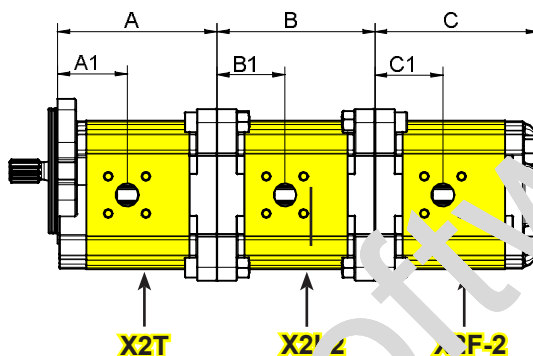
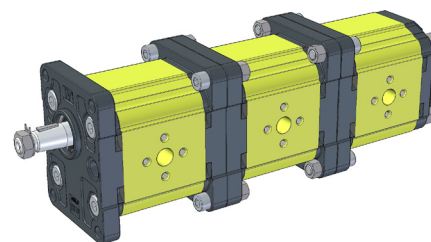
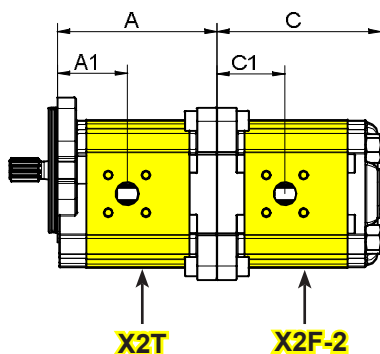
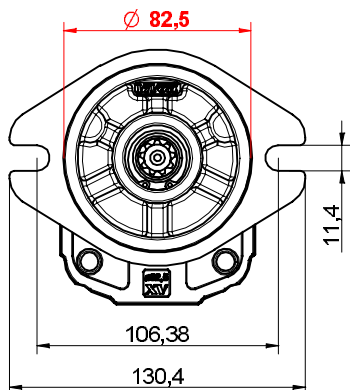

## SEPARATED STAGES

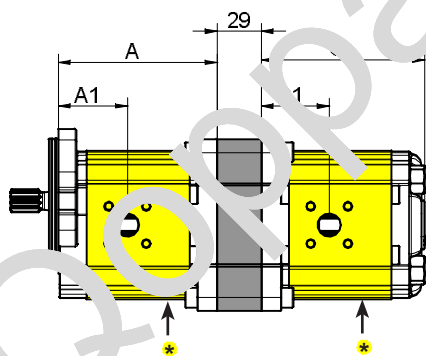

## SINGLE INLET

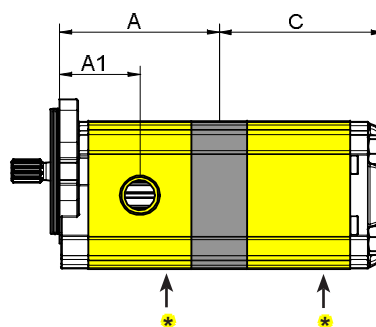

\* = SPECIAL ELEMENT, please contact our customer service for details.

TYPE	Displacem. cc/rev	A mm	A1 mm	B mm	B1 mm	C mm	C1 mm	P1 bar	P3 bar	Min speed rpm	Max speed rpm
XV-2 / 4	4,20	84,2	39,4	83,4	41,7	87,2	41,7	260	300	700	4000
XV-2 / 6	6,00	87,2	39,4	86,4	43,2	90,2	43,2	260	300	700	3500
XV-2 / 9	8,40	91,2	41,4	90,4	45,2	94,2	45,2	260	300	700	3500
XV-2 / 11	10,80	95,2	45,8	94,4	47,2	98,2	47,2	260	300	700	3500
XV-2 / 14	14,40	101,2	45,8	100,4	50,2	104,2	50,2	250	290	700	3500
XV-2 / 17	16,80	105,2	45,8	104,4	52,2	108,2	52,2	230	270	700	3500
XV-2 / 19	19,20	109,2	45,8	108,4	54,2	112,2	54,2	210	250	700	3000
XV-2 / 22	22,80	115,2	53,3	114,4	57,2	118,2	57,2	200	240	700	3000
XV-2 / 26	26,20	119,2	53,3	118,4	59,2	122,2	59,2	170	210	700	3000
XV-2 / 30	30,00	127,2	61,5	126,4	63,2	130,2	63,2	160	200	700	2500
XV-2 / 34	34,20	134,2	61,5	133,4	66,7	137,2	66,7	150	190	700	2500
XV-2 / 40	39,60	143,2	61,5	142,4	71,2	146,2	71,2	140	180	700	2000

# MULTIPLE PUMP XV-2

Ø 82,5 - FLANGE "SAE A"

**XV-2**

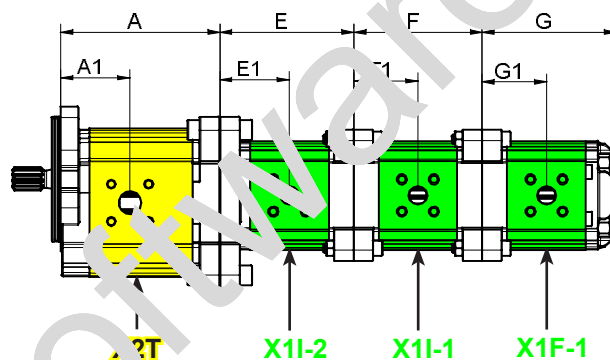
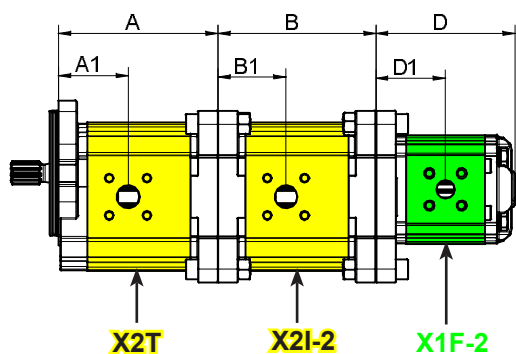
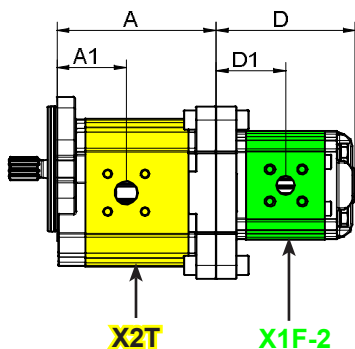
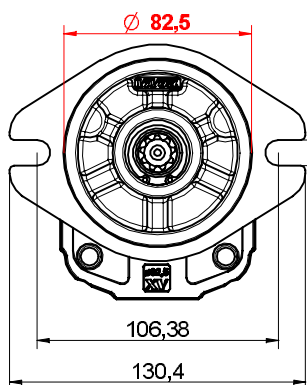

## SEPARATED STAGES

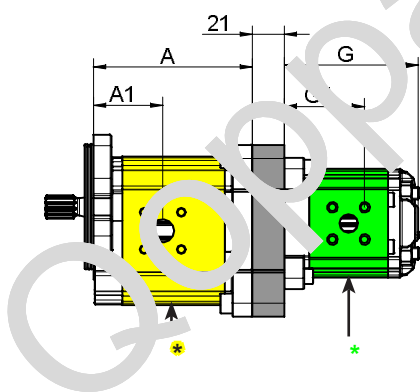

\* = SPECIAL ELEMENT, please contact our customer service for details.

TYPE	Displacem. cc/rev	A mm	A1 mm	B mm	B1 mm	C mm	C1 mm	P1 bar	P3 bar	Min speed rpm	Max speed rpm
XV-2 / 4	4,20	84,2	39,4	83,4	41,7	87,2	41,7	260	300	700	4000
XV-2 / 6	6,00	87,2	39,4	86,4	43,2	90,2	43,2	260	300	700	3500
XV-2 / 9	8,40	91,2	41,4	90,4	45,2	94,2	45,2	260	300	700	3500
XV-2 / 11	10,80	95,2	45,8	94,4	47,2	98,2	47,2	260	300	700	3500
XV-2 / 14	14,40	101,2	45,8	100,4	50,2	104,2	50,2	250	290	700	3500
XV-2 / 17	16,80	105,2	45,8	104,4	52,2	108,2	52,2	230	270	700	3500
XV-2 / 19	19,20	109,2	45,8	108,4	54,2	112,2	54,2	210	250	700	3000
XV-2 / 22	22,80	115,2	53,3	114,4	57,2	118,2	57,2	200	240	700	3000
XV-2 / 26	26,20	119,2	53,3	118,4	59,2	122,2	59,2	170	210	700	3000
XV-2 / 30	30,00	127,2	61,5	126,4	63,2	130,2	63,2	160	200	700	2500
XV-2 / 34	34,20	134,2	61,5	133,4	66,7	137,2	66,7	150	190	700	2500
XV-2 / 40	39,60	143,2	61,5	142,4	71,2	146,2	71,2	140	180	700	2000

# MULTIPLE PUMP XV-2

ø 82,5 - FLANGE "SAE A"

XV-2

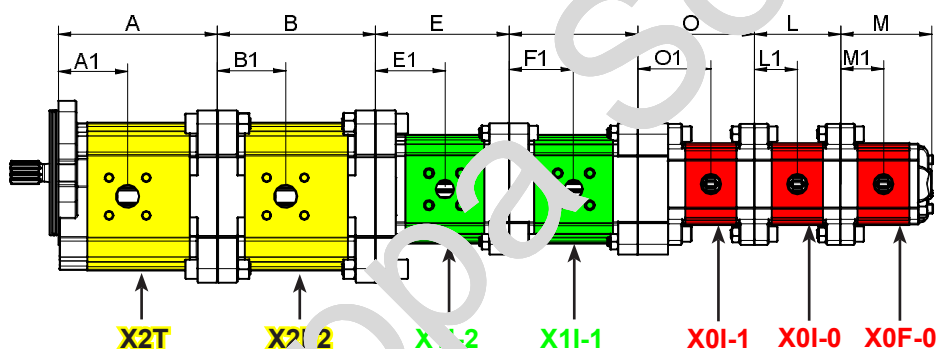
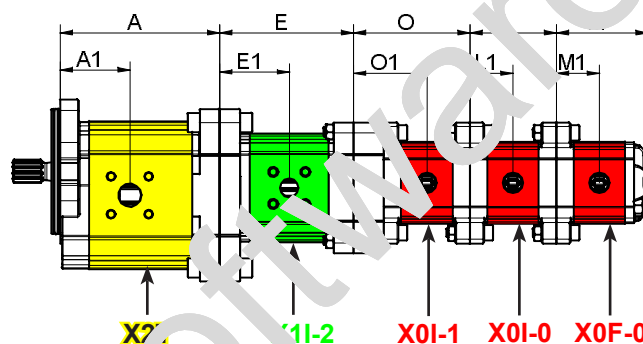
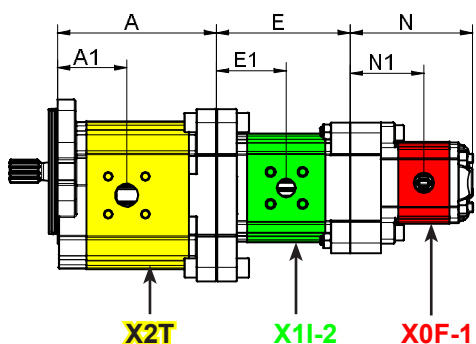
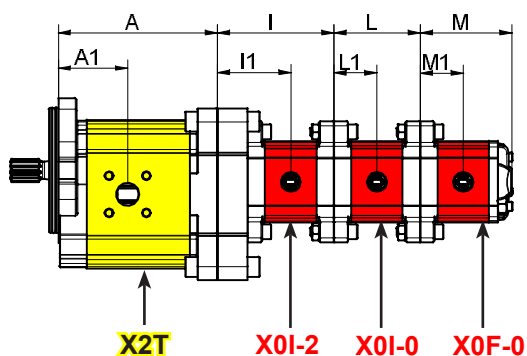
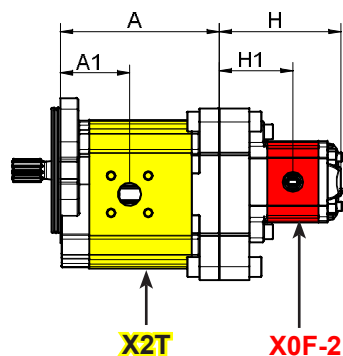

TYPE	Displacem. cc/rev	D mm	D1 mm	E mm	E1 mm	F mm	F1 mm	G mm	G1 mm	P1 bar	P3 bar	Min speed rpm	Max speed rpm
XV-1 / 0,9	0,91	81	40	3	40,8	74,5	37,3	78	37,3	240	280	700	6000
XV-1 / 1,2	1,16	82,5	41	3	41,3	75,5	37,8	79	37,8	250	290	700	6000
XV-1 / 1,7	1,6	84	42	3	42	77	38,5	80,5	38,5	250	290	700	6000
XV-1 / 2,2	2,08	86	43	3	43	79	39,5	82,5	39,5	250	290	700	6000
XV-1 / 2,6	2,6	88	44	3	44	81	40,5	84,5	40,5	250	300	700	6000
XV-1 / 3,2	3,1	90	45	3	45	83	41,5	86	41,5	250	300	700	6000
XV-1 / 3,8	3,64	92	46	3	46	85	42,5	88,5	42,5	250	300	700	6000
XV-1 / 4,3	4,26	94	47	3	47	87	43,5	90,5	43,5	250	300	700	6000
XV-1 / 4,9	4,94	97	48,5	3	48,5	90	45	93,5	45	250	300	700	6000
XV-1 / 5,9	5,85	100,5	50,3	3	50,3	93,5	46,8	97	46,8	250	300	700	5000
XV-1 / 6,5	6,50	103	51,5	3	51,5	96	48	99,5	48	250	300	700	5000
XV-1 / 7,8	7,54	107	53,5	3	53,5	100	50	103,5	50	220	260	700	5000
XV-1 / 9,8	9,88	116	58	3	58	109	54,5	112,5	54,5	190	230	700	4000

TYPE	Displacem. cc/rev	H mm	H1 mm	I mm	I1 mm	L mm	L1 mm	M mm	M1 mm	N mm	N1 mm	O mm	O1 mm	P1 bar	P3 bar	Min speed rpm	Max speed rpm
XV-0 / 0,17	0,16	75,8	46,2	72,3	46,2	52,3	26,2	55,8	26,2	75,8	46,2	72,3	46,2	220	260	700	9000
XV-0 / 0,25	0,24	76,4	46,5	72,9	46,5	52,9	26,5	56,4	26,5	76,4	46,5	72,9	46,5	220	260	700	9000
XV-0 / 0,45	0,45	78	47,3	74,5	47,3	54,5	27,3	58	27,3	78	47,3	74,5	47,3	220	280	700	9000
XV-0 / 0,57	0,56	79	47,8	75,5	47,8	55,5	27,8	59	27,8	79	47,8	75,5	47,8	220	280	700	9000
XV-0 / 0,76	0,75	80,5	48,5	77	48,5	57	28,5	60,5	28,5	80,5	48,5	77	48,5	220	280	700	9000
XV-0 / 0,98	0,92	82	49,3	78,5	49,3	58,5	29,3	62	29,3	82	49,3	78,5	49,3	220	280	700	6000
XV-0 / 1,27	1,26	84,5	50,5	81	50,5	61	30,5	64,5	30,5	84,5	50,5	81	50,5	220	280	700	6000
XV-0 / 1,52	1,48	86,5	51,5	83	51,5	63	31,5	66,5	31,5	86,5	51,5	83	51,5	220	280	700	6000
XV-0 / 2,30	2,28	92,5	54,5	89	54,5	69	34,5	72,5	34,5	92,5	54,5	89	54,5	220	210	700	5000



# MULTIPLE PUMP XV-3

ø 50,8 FLANGE

**XV-3**

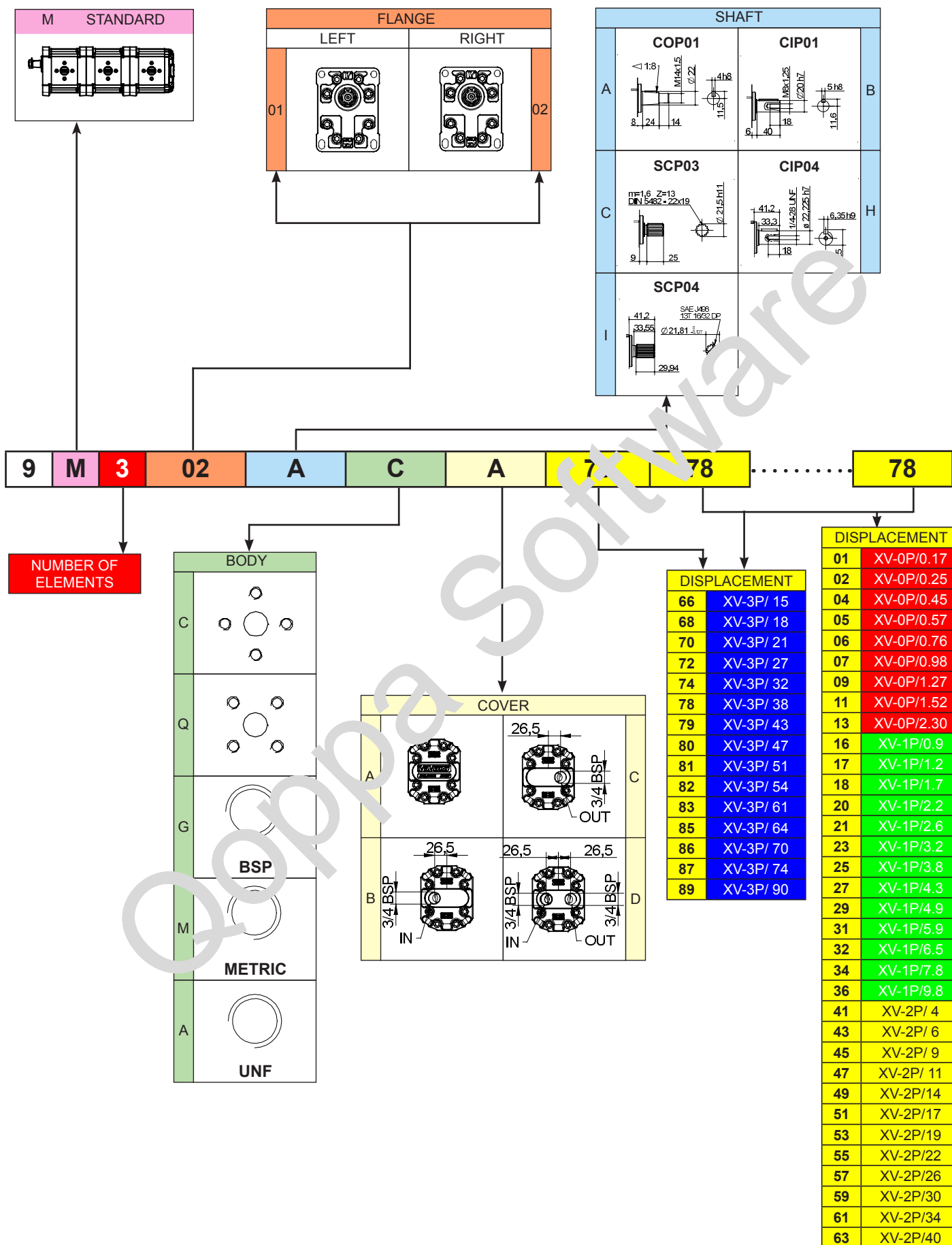

# MULTIPLE PUMP XV-3

Ø 50,8 FLANGE

**XV-3**

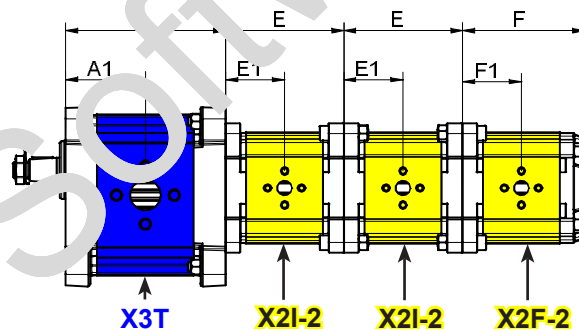
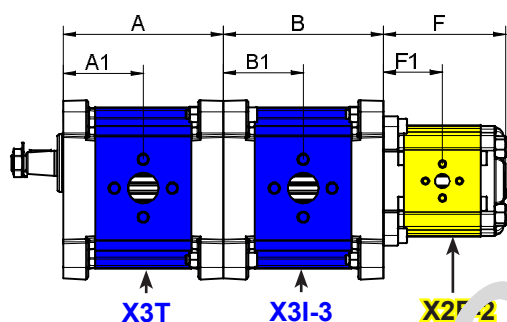
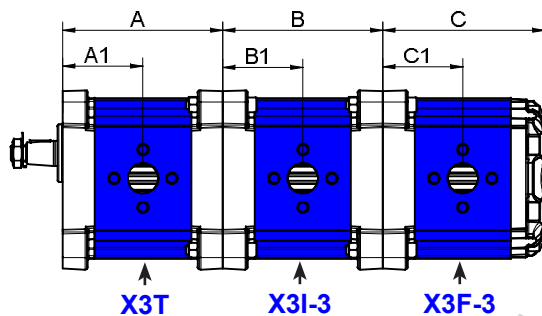
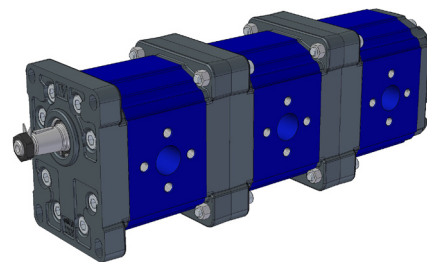
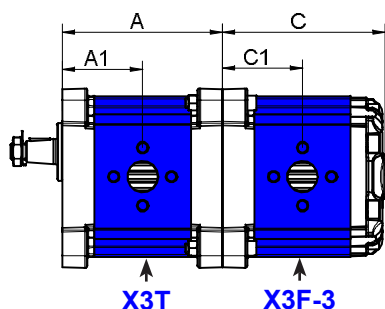
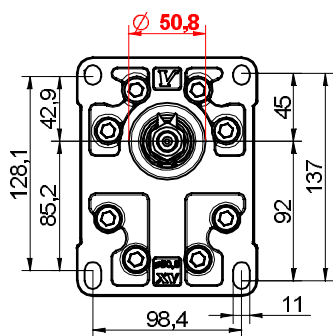

TYPE	Displacem. cc/rev	A mm	A1 mm	B mm	B1 mm	C mm	C1 mm	P1 bar	P3 bar	Min speed rpm	Max speed rpm
XV-3 / 15	14,89	122	61	62	61	124	61	300	320	700	3000
XV-3 / 18	17,37	124	62	62	62	126	62	300	320	700	3000
XV-3 / 21	21,10	127	63,5	127	63,5	129	63,5	280	300	700	3000
XV-3 / 27	26,97	131	65,5	131	65,5	133	65,5	250	270	700	3000
XV-3 / 32	32,27	136	68	136	68	138	68	250	270	700	3000
XV-3 / 38	38,47	141	70,5	141	70,5	143	70,5	250	270	700	2800
XV-3 / 43	43,46	145	72,5	145	72,5	147	72,5	250	270	700	2800
XV-3 / 47	47,16	148	74	148	74	150	74	230	250	700	2800
XV-3 / 51	51,88	151	75,5	151	75,5	153	75,5	230	250	700	2800
XV-3 / 54	54,30	154	77	154	77	156	77	230	250	700	2300
XV-3 / 61	60,19	159	79,5	159	79,5	161	79,5	230	250	700	2300
XV-3 / 64	64,55	162	81	162	81	164	81	210	230	700	2300
XV-3 / 70	70,74	167	83,5	167	83,5	169	83,5	200	220	700	2300
XV-3 / 74	74,46	170	85	170	85	172	85	180	200	700	2300
XV-3 / 90	86,87	180	90	180	90	182	90	150	170	700	2300

TYPE	Displacem. cc/rev	E mm	E1 mm	F mm	F1 mm	P1 bar	P3 bar	Min speed rpm	Max speed rpm
XV-2 / 4	4,20	83,4	41,7	87,2	41,7	260	300	700	4000
XV-2 / 6	6,00	86,4	43,2	90,2	43,2	260	300	700	3500
XV-2 / 9	8,40	90,4	45,2	94,2	45,2	260	300	700	3500
XV-2 / 11	10,80	94,4	47,2	98,2	47,2	260	300	700	3500
XV-2 / 14	14,40	100,4	50,2	104,2	50,2	250	290	700	3500
XV-2 / 17	16,80	104,4	52,2	108,2	52,2	230	270	700	3500
XV-2 / 19	19,20	108,4	54,2	112,2	54,2	210	250	700	3000
XV-2 / 22	22,80	114,4	57,2	118,2	57,2	200	240	700	3000
XV-2 / 26	26,20	118,4	59,2	122,2	59,2	170	210	700	3000
XV-2 / 30	30,00	126,4	63,2	130,2	63,2	160	200	700	2500
XV-2 / 34	34,20	133,4	66,7	137,2	66,7	150	190	700	2500
XV-2 / 40	39,60	142,4	71,2	146,2	71,2	140	180	700	2000

**MULTIPLE PUMP XV-3**  
**BASE  $\varnothing$  50,8 - STANDARD**

**XV-3**

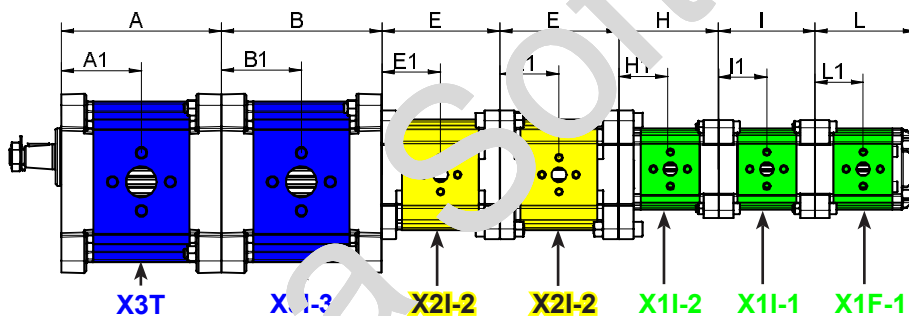
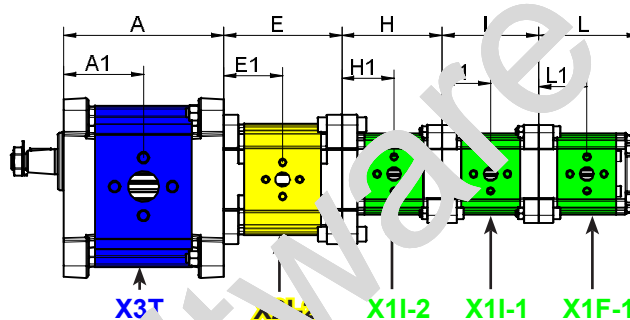
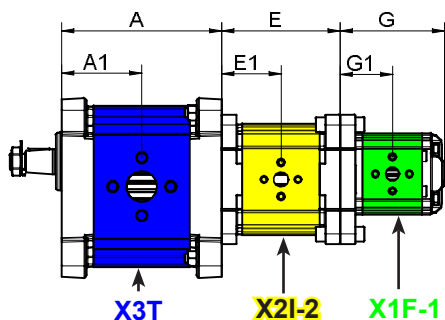
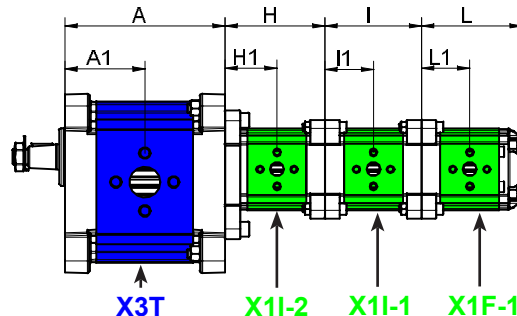
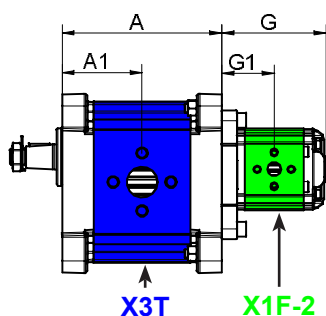
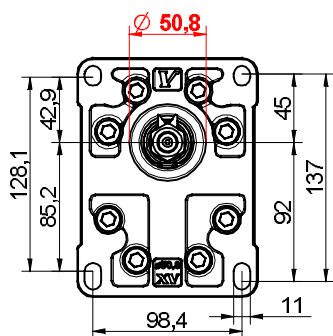

TYPE	Displacem. cc/rev	A mm	A1 mm	B mm	B1 mm	C mm	C1 mm	P1 bar	P3 bar	Min speed rpm	Max speed rpm
XV-3 / 15	14,89	122	61	122	61	124	61	300	320	700	3000
XV-3 / 18	17,37	124	62	124	62	126	62	300	320	700	3000
XV-3 / 21	21,10	127	63,5	127	63,5	129	63,5	280	300	700	3000
XV-3 / 27	26,97	131	65,5	131	65,5	133	65,5	250	270	700	3000
XV-3 / 32	32,27	136	68	136	68	138	68	250	270	700	3000
XV-3 / 38	38,47	141	70,5	141	70,5	143	70,5	250	270	700	2800
XV-3 / 43	43,47	145	72,5	145	72,5	147	72,5	250	270	700	2800
XV-3 / 47	47,16	148	74	148	74	150	74	230	250	700	2800
XV-3 / 51	51,88	151	75,5	151	75,5	153	75,5	230	250	700	2800
XV-3 / 54	54,30	154	77	154	77	156	77	230	250	700	2300
XV-3 / 61	60,19	159	79,5	159	79,5	161	79,5	230	250	700	2300
XV-3 / 64	64,55	162	81	162	81	164	81	210	230	700	2300
XV-3 / 70	70,74	167	83,5	167	83,5	169	83,5	200	220	700	2300
XV-3 / 74	74,46	170	85	170	85	172	85	180	200	700	2300
XV-3 / 90	86,87	180	90	180	90	182	90	150	170	700	2300

TYPE	Displacem. cc/rev	E mm	E1 mm	F mm	F1 mm	P1 bar	P3 bar	Min speed rpm	Max speed rpm
XV-2 / 4	4,20	83,4	41,7	87,2	41,7	260	300	700	4000
XV-2 / 6	6,00	86,4	43,2	90,2	43,2	260	300	700	3500
XV-2 / 9	8,40	90,4	45,2	94,2	45,2	260	300	700	3500
XV-2 / 11	10,80	94,4	47,2	98,2	47,2	260	300	700	3500
XV-2 / 14	14,40	100,4	50,2	104,2	50,2	250	290	700	3500
XV-2 / 17	16,80	104,4	52,2	108,2	52,2	230	270	700	3500
XV-2 / 19	19,20	108,4	54,2	112,2	54,2	210	250	700	3000
XV-2 / 22	22,80	114,4	57,2	118,2	57,2	200	240	700	3000
XV-2 / 26	26,20	118,4	59,2	122,2	59,2	170	210	700	3000
XV-2 / 30	30,00	126,4	63,2	130,2	63,2	160	200	700	2500
XV-2 / 34	34,20	133,4	66,7	137,2	66,7	150	190	700	2500
XV-2 / 40	39,60	142,4	71,2	146,2	71,2	140	180	700	2000

# MULTIPLE PUMP XV-3

ø 50,8 FLANGE

**XV-3**

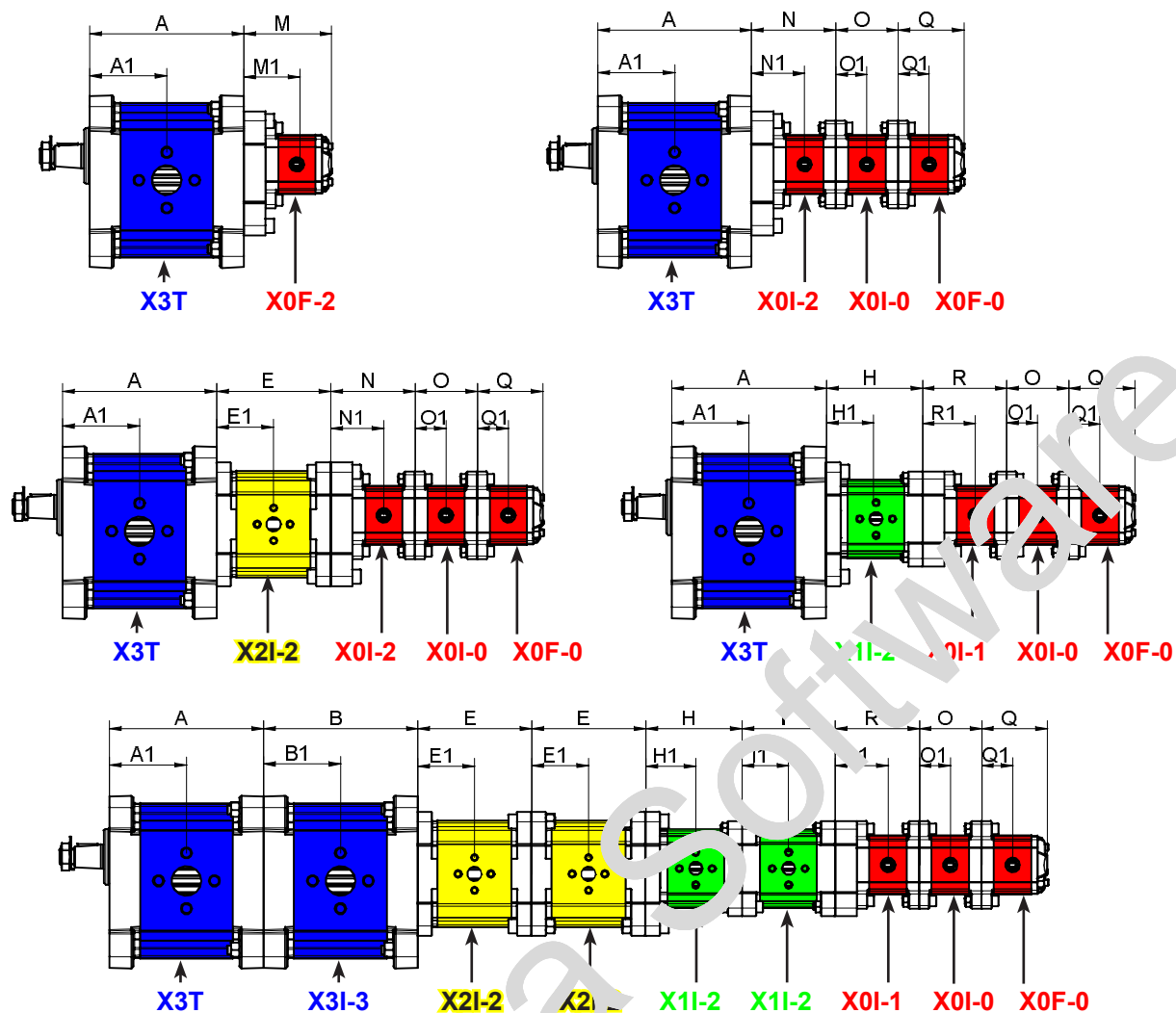

TYPE	Displacem. cc/rev	G mm	G1 mm	I mm	H1 mm	I mm	I1 mm	L mm	L1 mm	P1 bar	P3 bar	Min speed rpm	Max speed rpm
XV-1 / 0,9	0,91	81,5	40,5	73	40,8	74,5	37,3	78	37,3	240	280	700	6000
XV-1 / 1,2	1,16	82,5	41,5	79	41,3	75,5	37,8	79	37,8	250	290	700	6000
XV-1 / 1,7	1,6	84,5	42,5	80,5	42	77	38,5	80,5	38,5	250	290	700	6000
XV-1 / 2,2	2,08	86,5	43,5	82,5	43	79	39,5	82,5	39,5	250	290	700	6000
XV-1 / 2,6	2,6	88,5	44,5	84,5	44	81	40,5	84,5	40,5	250	300	700	6000
XV-1 / 3,2	3,16	90,5	45,5	86	45	83	41,5	86	41,5	250	300	700	6000
XV-1 / 3,8	3,64	92,5	46,5	88,5	46	85	42,5	88,5	42,5	250	300	700	6000
XV-1 / 4,3	4,26	94,5	47,5	90,5	47	87	43,5	90,5	43,5	250	300	700	6000
XV-1 / 4,9	4,94	97,5	48,5	93,5	48,5	90	45	93,5	45	250	300	700	6000
XV-1 / 5,9	5,85	100,5	50,3	97	50,3	93,5	46,8	97	46,8	250	300	700	5000
XV-1 / 6,5	6,50	103	51,5	99,5	51,5	96	48	99,5	48	250	300	700	5000
XV-1 / 7,8	7,54	107	53,5	103,5	53,5	100	50	103,5	50	220	260	700	5000
XV-1 / 9,8	9,88	116	58	112,5	58	109	54,5	112,5	54,5	190	230	700	4000

TYPE	Displacem. cc/rev	M mm	M1 mm	N mm	N1 mm	O mm	O1 mm	Q mm	Q1 mm	R mm	R1 mm	P1 bar	P3 bar	Min speed rpm	Max speed rpm
XV-0 / 0,17	0,16	75,8	46,2	72,3	46,2	52,3	26,2	55,8	26,2	72,3	46,2	220	260	700	9000
XV-0 / 0,25	0,24	76,4	46,5	72,9	46,5	52,9	26,5	56,4	26,5	72,9	46,5	220	260	700	9000
XV-0 / 0,45	0,45	78	47,3	74,5	47,3	54,5	27,3	58	27,3	74,5	47,3	220	280	700	9000
XV-0 / 0,57	0,56	79	47,8	75,5	47,8	55,5	27,8	59	27,8	75,5	47,8	220	280	700	9000
XV-0 / 0,76	0,75	80,5	48,5	77	48,5	57	28,5	60,5	28,5	77	48,5	220	280	700	9000
XV-0 / 0,98	0,92	82	49,3	78,5	49,3	58,5	29,3	62	29,3	78,5	49,3	220	280	700	6000
XV-0 / 1,27	1,26	84,5	50,5	81	50,5	61	30,5	64,5	30,5	81	50,5	220	280	700	6000
XV-0 / 1,52	1,48	86,5	51,5	83	51,5	63	31,5	66,5	31,5	83	51,5	220	280	700	6000
XV-0 / 2,30	2,28	92,5	54,5	89	54,5	69	34,5	72,5	34,5	89	54,5	220	210	700	5000

# MULTIPLE PUMP XV-3

Ø 101,6 FLANGE "SAE B"

**XV-3**

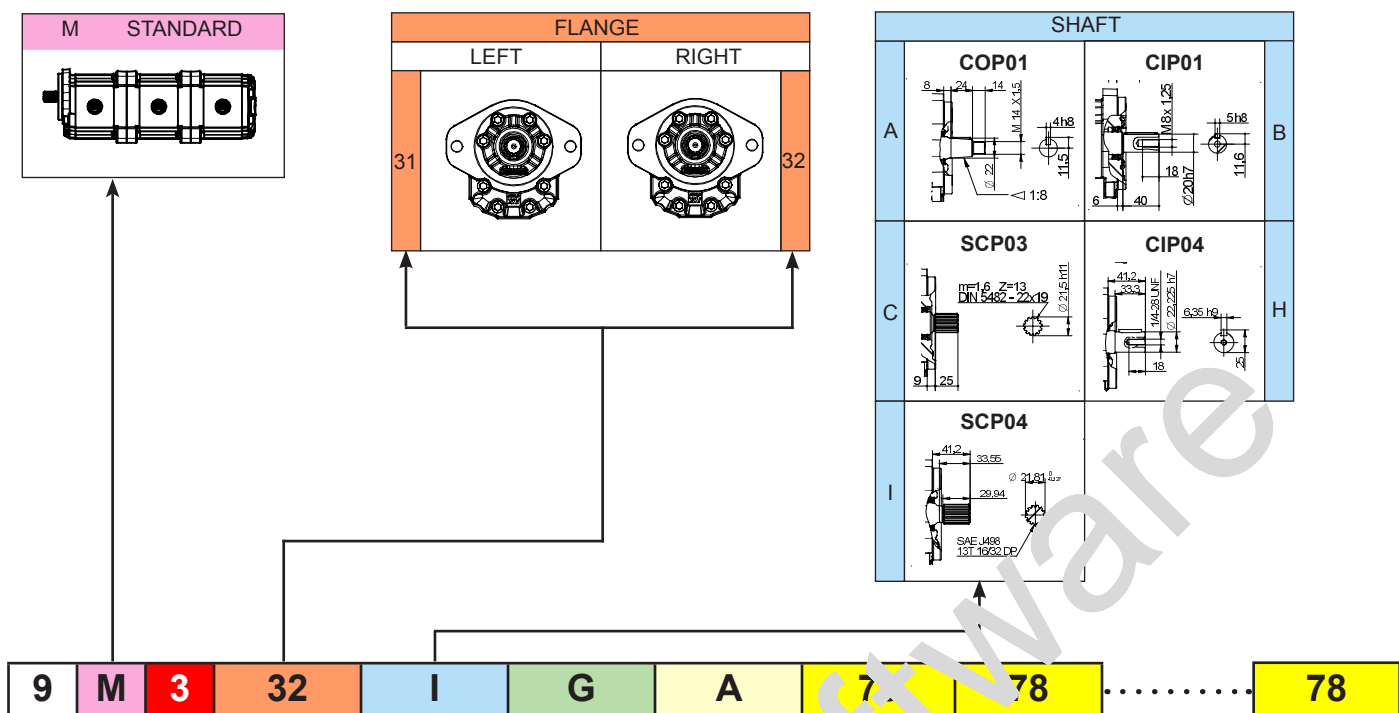

NUMBER OF ELEMENTS

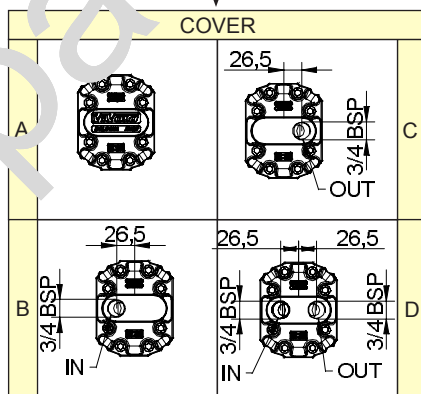
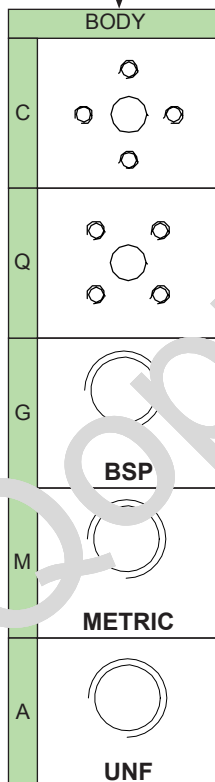

DISPLACEMENT	
66	XV-3P/ 15
68	XV-3P/ 18
70	XV-3P/ 21
72	XV-3P/ 27
74	XV-3P/ 32
78	XV-3P/ 38
79	XV-3P/ 43
80	XV-3P/ 47
81	XV-3P/ 51
82	XV-3P/ 54
83	XV-3P/ 61
85	XV-3P/ 64
86	XV-3P/ 70
87	XV-3P/ 74
89	XV-3P/ 90

DISPLACEMENT	
01	XV-0P/0.17
02	XV-0P/0.25
04	XV-0P/0.45
05	XV-0P/0.57
06	XV-0P/0.76
07	XV-0P/0.98
09	XV-0P/1.27
11	XV-0P/1.52
13	XV-0P/2.30
16	XV-1P/0.9
17	XV-1P/1.2
18	XV-1P/1.7
20	XV-1P/2.2
21	XV-1P/2.6
23	XV-1P/3.2
25	XV-1P/3.8
27	XV-1P/4.3
29	XV-1P/4.9
31	XV-1P/5.9
32	XV-1P/6.5
34	XV-1P/7.8
36	XV-1P/9.8
41	XV-2P/ 4
43	XV-2P/ 6
45	XV-2P/ 9
47	XV-2P/ 11
49	XV-2P/14
51	XV-2P/17
53	XV-2P/19
55	XV-2P/22
57	XV-2P/26
59	XV-2P/30
61	XV-2P/34
63	XV-2P/40

# MULTIPLE PUMP XV-3

Ø 101,6 FLANGE "SAE B"

**XV-3**

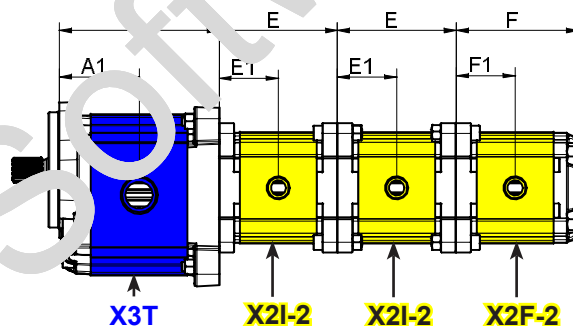
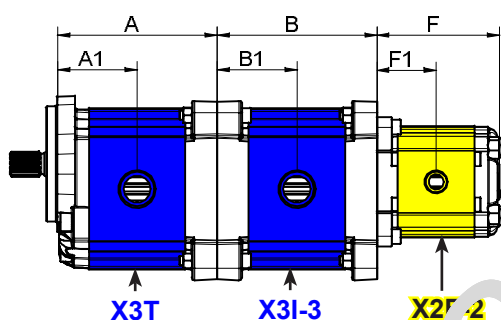
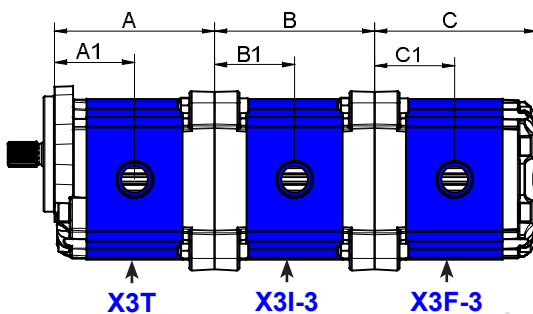
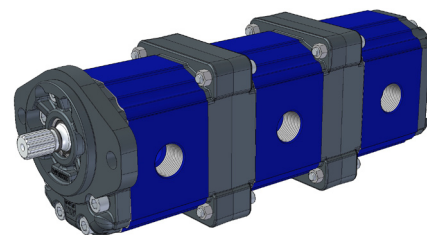
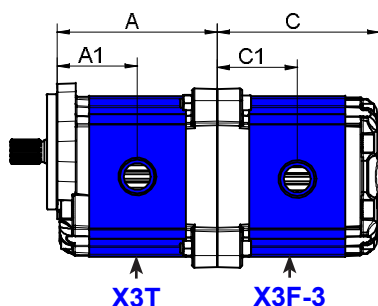
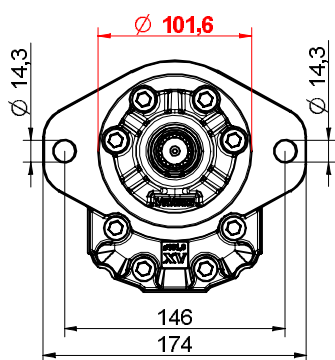

TYPE	Displacem. cc/rev	A mm	A1 mm	B mm	B1 mm	C mm	C1 mm	P1 bar	P3 bar	Min speed rpm	Max speed rpm
XV-3 / 15	14,89	122	61	122	61	124	61	300	320	700	3000
XV-3 / 18	17,37	124	62	124	62	126	62	300	320	700	3000
XV-3 / 21	21,10	127	63,5	127	63,5	129	63,5	280	300	700	3000
XV-3 / 27	26,97	131	65,5	131	65,5	133	65,5	250	270	700	3000
XV-3 / 32	32,27	136	68	136	68	138	68	250	270	700	3000
XV-3 / 38	38,47	141	70,5	141	70,5	143	70,5	250	270	700	2800
XV-3 / 43	43,47	145	72,5	145	72,5	147	72,5	250	270	700	2800
XV-3 / 47	47,16	148	74	148	74	150	74	230	250	700	2800
XV-3 / 51	51,88	151	75,5	151	75,5	153	75,5	230	250	700	2800
XV-3 / 54	54,30	154	77	154	77	156	77	230	250	700	2300
XV-3 / 61	60,19	159	79,5	159	79,5	161	79,5	230	250	700	2300
XV-3 / 64	64,55	162	81	162	81	164	81	210	230	700	2300
XV-3 / 70	70,74	167	83,5	167	83,5	169	83,5	200	220	700	2300
XV-3 / 74	74,46	170	85	170	85	172	85	180	200	700	2300
XV-3 / 90	86,87	180	90	180	90	182	90	150	170	700	2300

TYPE	Displacem. cc/rev	E mm	E1 mm	F mm	F1 mm	P1 bar	P3 bar	Min speed rpm	Max speed rpm
XV-2 / 4	4,20	83,4	41,7	87,2	41,7	260	300	700	4000
XV-2 / 6	6,00	86,4	43,2	90,2	43,2	260	300	700	3500
XV-2 / 9	8,40	90,4	45,2	94,2	45,2	260	300	700	3500
XV-2 / 11	10,80	94,4	47,2	98,2	47,2	260	300	700	3500
XV-2 / 14	14,40	100,4	50,2	104,2	50,2	250	290	700	3500
XV-2 / 17	16,80	104,4	52,2	108,2	52,2	230	270	700	3500
XV-2 / 19	19,20	108,4	54,2	112,2	54,2	210	250	700	3000
XV-2 / 22	22,80	114,4	57,2	118,2	57,2	200	240	700	3000
XV-2 / 26	26,20	118,4	59,2	122,2	59,2	170	210	700	3000
XV-2 / 30	30,00	126,4	63,2	130,2	63,2	160	200	700	2500
XV-2 / 34	34,20	133,4	66,7	137,2	66,7	150	190	700	2500
XV-2 / 40	39,60	142,4	71,2	146,2	71,2	140	180	700	2000

# MULTIPLE PUMP XV-3

Ø 101,6 FLANGE "SAE B"

**XV-3**

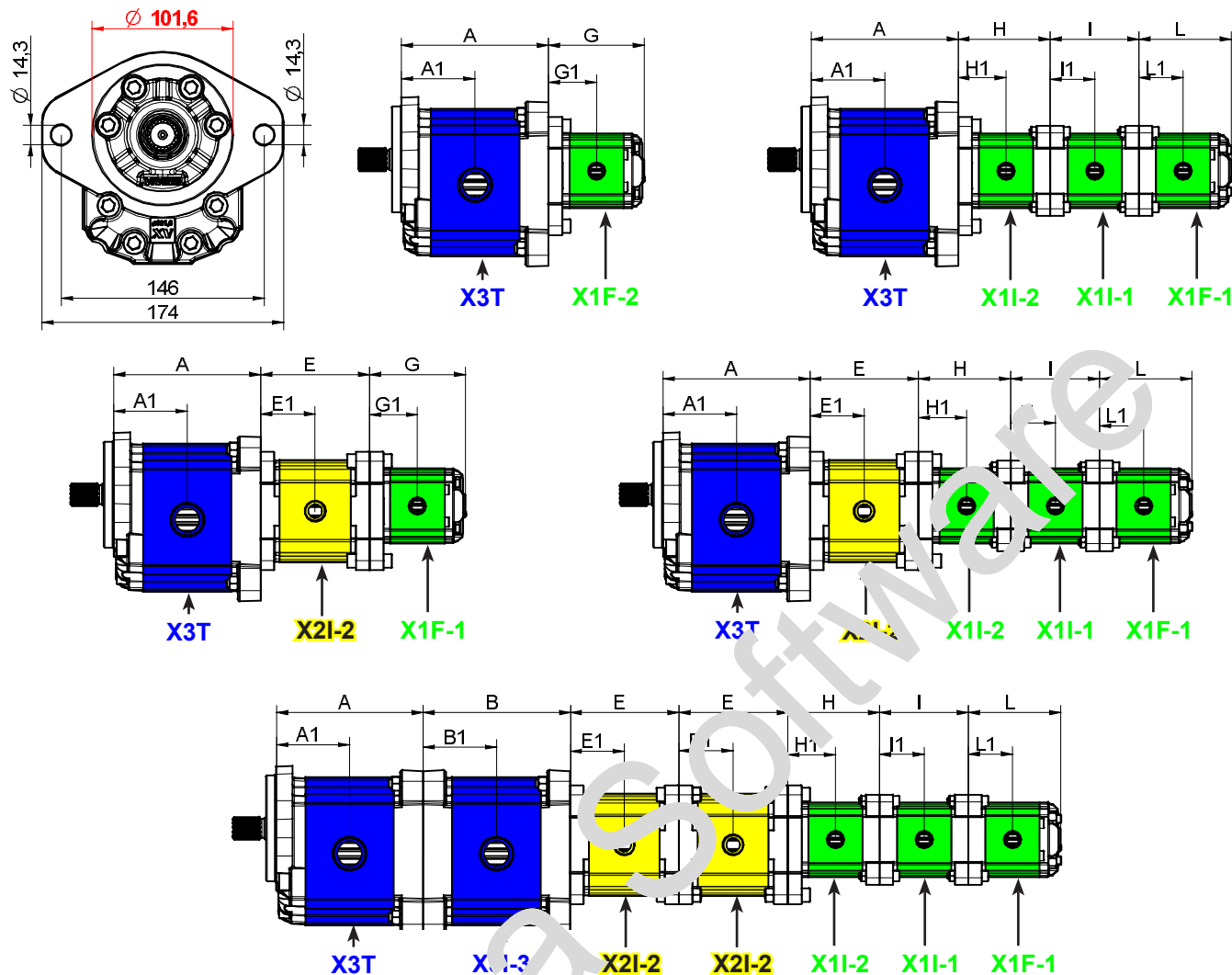

TYPE	Displacem. cc/rev	A mm	A1 mm	B mm	B1 mm	C mm	C1 mm	P1 bar	P3 bar	Min speed rpm	Max speed rpm
XV-3 / 15	14,89	122	61	122	61	124	61	300	320	700	3000
XV-3 / 18	17,37	124	62	124	62	126	62	300	320	700	3000
XV-3 / 21	21,10	127	63,5	127	63,5	129	63,5	280	300	700	3000
XV-3 / 27	26,97	131	65,5	131	65,5	133	65,5	250	270	700	3000
XV-3 / 32	32,27	136	68	136	68	138	68	250	270	700	3000
XV-3 / 38	38,47	141	70,5	141	70,5	143	70,5	250	270	700	2800
XV-3 / 43	43,47	145	72,5	145	72,5	147	72,5	250	270	700	2800
XV-3 / 47	47,16	148	74	148	74	150	74	230	250	700	2800
XV-3 / 51	51,88	151	75,5	151	75,5	153	75,5	230	250	700	2800
XV-3 / 54	54,30	154	77	154	77	156	77	230	250	700	2300
XV-3 / 61	60,19	159	79,5	159	79,5	161	79,5	230	250	700	2300
XV-3 / 64	64,55	162	81	162	81	164	81	210	230	700	2300
XV-3 / 70	70,74	167	83,5	167	83,5	169	83,5	200	220	700	2300
XV-3 / 74	74,46	170	85	170	85	172	85	180	200	700	2300
XV-3 / 90	86,87	180	90	180	90	182	90	150	170	700	2300

TYPE	Displacem. cc/rev	E mm	E1 mm	F mm	F1 mm	P1 bar	P3 bar	Min speed rpm	Max speed rpm
XV-2 / 4	4,20	83,4	41,7	87,2	41,7	260	300	700	4000
XV-2 / 6	6,00	86,4	43,2	90,2	43,2	260	300	700	3500
XV-2 / 9	8,40	90,4	45,2	94,2	45,2	260	300	700	3500
XV-2 / 11	10,80	94,4	47,2	98,2	47,2	260	300	700	3500
XV-2 / 14	14,40	100,4	50,2	104,2	50,2	250	290	700	3500
XV-2 / 17	16,80	104,4	52,2	108,2	52,2	230	270	700	3500
XV-2 / 19	19,20	108,4	54,2	112,2	54,2	210	250	700	3000
XV-2 / 22	22,80	114,4	57,2	118,2	57,2	200	240	700	3000
XV-2 / 26	26,20	118,4	59,2	122,2	59,2	170	210	700	3000
XV-2 / 30	30,00	126,4	63,2	130,2	63,2	160	200	700	2500
XV-2 / 34	34,20	133,4	66,7	137,2	66,7	150	190	700	2500
XV-2 / 40	39,60	142,4	71,2	146,2	71,2	140	180	700	2000

# MULTIPLE PUMP XV-3

ø 101,6 FLANGE "SAE B"

**XV-3**

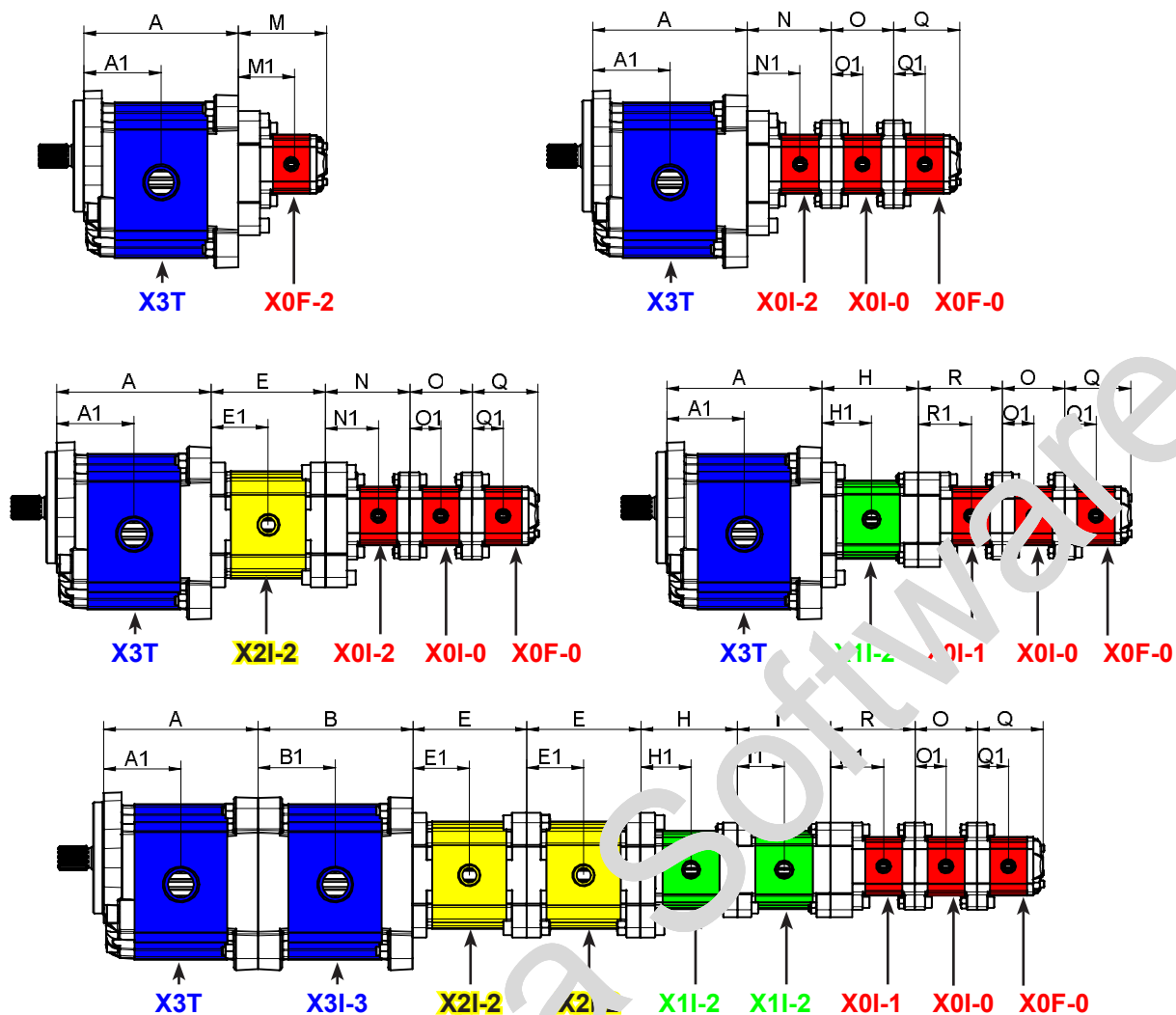

TYPE	Displacem. cc/rev	G mm	G1 mm	H mm	H1 mm	I mm	I1 mm	L mm	L1 mm	P1 bar	P3 bar	Min speed rpm	Max speed rpm
XV-1 / 0,9	0,91	81,5	40,5	33	40,8	74,5	37,3	78	37,3	240	280	700	6000
XV-1 / 1,2	1,16	82,5	41,5	33	41,3	75,5	37,8	79	37,8	250	290	700	6000
XV-1 / 1,7	1,66	84,5	42,5	33	42	77	38,5	80,5	38,5	250	290	700	6000
XV-1 / 2,2	2,08	86,5	43,5	33	42,5	79	39,5	82,5	39,5	250	290	700	6000
XV-1 / 2,6	2,6	88,5	44,5	33	44	81	40,5	84,5	40,5	250	300	700	6000
XV-1 / 3,2	3,16	90,5	45,5	33	45	83	41,5	86	41,5	250	300	700	6000
XV-1 / 3,8	3,64	92,5	46,5	33	46	85	42,5	88,5	42,5	250	300	700	6000
XV-1 / 4,3	4,26	94,5	47,5	33	47	87	43,5	90,5	43,5	250	300	700	6000
XV-1 / 4,9	4,94	97,5	48,5	33	48,5	90	45	93,5	45	250	300	700	6000
XV-1 / 5,9	5,85	100,5	50,3	33	50,3	93,5	46,8	97	46,8	250	300	700	5000
XV-1 / 6,5	6,50	103	51,5	33	51,5	96	48	99,5	48	250	300	700	5000
XV-1 / 7,8	7,54	107	53,5	33	53,5	100	50	103,5	50	220	260	700	5000
XV-1 / 9,8	9,88	116	58	33	58	109	54,5	112,5	54,5	190	230	700	4000

TYPE	Displacem. cc/rev	M mm	M1 mm	N mm	N1 mm	O mm	O1 mm	Q mm	Q1 mm	R mm	R1 mm	P1 bar	P3 bar	Min speed rpm	Max speed rpm
XV-0 / 0,17	0,16	75,8	46,2	72,3	46,2	52,3	26,2	55,8	26,2	72,3	46,2	220	260	700	9000
XV-0 / 0,25	0,24	76,4	46,5	72,9	46,5	52,9	26,5	56,4	26,5	72,9	46,5	220	260	700	9000
XV-0 / 0,45	0,45	78	47,3	74,5	47,3	54,5	27,3	58	27,3	74,5	47,3	220	280	700	9000
XV-0 / 0,57	0,56	79	47,8	75,5	47,8	55,5	27,8	59	27,8	75,5	47,8	220	280	700	9000
XV-0 / 0,76	0,75	80,5	48,5	77	48,5	57	28,5	60,5	28,5	77	48,5	220	280	700	9000
XV-0 / 0,98	0,92	82	49,3	78,5	49,3	58,5	29,3	62	29,3	78,5	49,3	220	280	700	6000
XV-0 / 1,27	1,26	84,5	50,5	81	50,5	61	30,5	64,5	30,5	81	50,5	220	280	700	6000
XV-0 / 1,52	1,48	86,5	51,5	83	51,5	63	31,5	66,5	31,5	83	51,5	220	280	700	6000
XV-0 / 2,30	2,28	92,5	54,5	89	54,5	69	34,5	72,5	34,5	89	54,5	220	210	700	5000



Qoppa Software

# MULTIPLE PUMPS – SINGLE ELEMENTS

## SINGLE ELEMENTS

The catalogue is ordered by dimensional groups and connecting flanges. For each element, characterized by the connecting flange, two pages are prepared as you can see in the following picture. From the different sections it is possible to find out:

1. Structure of the Product Code corresponding to the **purchasing code** starting from the specific characteristics.
2. Typology reference – it identifies the family (primary, intermediate or final element) and the dimensional group.
3. Three-dimensional representation of the kind of product and reference to the typologies by which the assembly is possible.
4. Reference for the product identification inside the price list.
5. Product drawing and dimensions depending on the displacement.
6. Table of the variants by which it is possible to identify the product details and compose the code.

**pompa trascinatrice - serie XV**  
**POMPA TRASCINATRICE STANDARD**  
**BASE ø30 - ALBERO CONICO**

**X1T 25 12 G I I A**

Serie X serie XV  
 Gruppo T gruppo I  
 Categoria T pompa trascinatrice  
 Cilindrata 25 5.8  
 Base 12 Ø30 STANDARD rotazione destra  
 Albero G COP92 - Conico 1.8 - ø14 - M10x1 - linguaetta sp.5  
 Corpo IN I aspirazione - Ø30 Ø12 M8  
 OUT I mossa - Ø30 Ø12 M8  
 Coperchio A femmina ø25.4

**XT113**

TIPO	Cilindrata cm³/giro	Pressione Max.		CODICE	
		P1 bar	P3 bar	Rotazione Sinistra	Rotazione destra
X1T0.9	0,91	240	280	X 1 T 18 11 G I I A	X 1 T 18 12 G I I A
X1T1.2	1,17	250	290	X 1 T 17 11 G I I A	X 1 T 17 12 G I I A
X1T1.7	1,58	250	290	X 1 T 18 11 G I I A	X 1 T 18 12 G I I A
X1T2.2	2,08	250	290	X 1 T 20 11 G I I A	X 1 T 20 12 G I I A
X1T2.6	2,80	250	300	X 1 T 21 11 G I I A	X 1 T 21 12 G I I A
X1T3.2	3,12	250	300	X 1 T 23 11 G I I A	X 1 T 23 12 G I I A
X1T3.8	3,84	250	300	X 1 T 25 11 G I I A	X 1 T 25 12 G I I A
X1T4.3	4,16	250	300	X 1 T 27 11 G I I A	X 1 T 27 12 G I I A
X1T4.9	4,84	250	300	X 1 T 29 11 G I I A	X 1 T 29 12 G I I A
X1T5.9	5,85	250	300	X 1 T 31 11 G I I A	X 1 T 31 12 G I I A
X1T6.5	6,50	250	300	X 1 T 32 11 G I I A	X 1 T 32 12 G I I A
X1T7.8	7,64	220	260	X 1 T 34 11 G I I A	X 1 T 34 12 G I I A
X1T8.8	9,88	190	230	X 1 T 36 11 G I I A	X 1 T 36 12 G I I A

*P1) Pressione max. di esercizio - P3) Pressione max. di picco*  
 Per applicazioni gravose si consiglia di verificare la coppia ammissibile dell'albero

TIPO	Peso kg	A		D	E	F	D	E	F
		mm	mm						
X1T0.9	0,950	74,5	37,3	ø12	30	M6x1	ø12	30	M6x1
X1T1.2	0,970	75,5	37,8	ø12	30	M6x1	ø12	30	M6x1
X1T1.7	1,010	77,0	38,5	ø12	30	M6x1	ø12	30	M6x1
X1T2.2	1,030	78,0	38,5	ø12	30	M6x1	ø12	30	M6x1
X1T2.6	1,060	81,0	40,5	ø12	30	M6x1	ø12	30	M6x1
X1T3.2	1,090	83,0	41,5	ø12	30	M6x1	ø12	30	M6x1
X1T3.8	1,120	85,0	42,5	ø12	30	M6x1	ø12	30	M6x1
X1T4.3	1,170	87,0	43,5	ø12	30	M6x1	ø12	30	M6x1
X1T4.9	1,200	90,0	45,0	ø12	30	M6x1	ø12	30	M6x1
X1T5.9	1,260	93,5	46,8	ø12	30	M6x1	ø12	30	M6x1
X1T6.5	1,300	96,0	48,0	ø12	30	M6x1	ø12	30	M6x1
X1T7.8	1,360	100,0	50,0	ø12	30	M6x1	ø12	30	M6x1
X1T8.8	1,500	109,0	54,5	ø12	30	M6x1	ø12	30	M6x1

T.1 = 24.4-29.4 [Nm] - coppia di serraggio viti M8  
 T.2 = 119.8 [Nm] - coppia di serraggio viti M10x1  
 scelta dell'utensile da utilizzare per la coppia ammissibile dell'albero (N.B. verificare sempre la coppia ammissibile).

Vivoli Oleodinamica s.r.l. - Società a Socio Unico - via Leone Ginzburg 2-4 40054 Budrio (BO) Italy tel. +39 051 803689 fax +39 051 800061  
 XT113 www.vivoli.com - italiano 15/05/2008

**Tavola delle varianti**

**BASE ø30**

Rotazione Sinistra	BASE ø30		Cilindrata		Coperchio	
	11	12	16	18	Rotazione Sinistra	Rotazione destra

TIPO	CODICE	Cilindrata		Flettatore standard				
		cm³/giro	Pressione Max.	TIPO	Pressione Max.			
X1T0.9	16	0,9	1-1	B-B	J-J	B-Z	Z-Z	G-F
X1T1.2	17	1,2	1-1	B-B	J-J	B-Z	Z-Z	G-F
X1T1.7	18	1,7	1-1	B-B	J-J	B-Z	Z-Z	G-F
X1T2.2	20	2,2	1-1	B-B	J-J	B-Z	Z-Z	G-F
X1T2.6	21	2,6	1-1	B-B	J-J	B-Z	Z-Z	G-F
X1T3.2	23	3,2	1-1	B-B	J-J	B-Z	Z-Z	G-F
X1T3.8	25	3,8	1-1	B-B	J-J	B-Z	Z-Z	G-F
X1T4.3	27	4,3	1-1	B-B	J-J	B-Z	Z-Z	G-F
X1T4.9	29	4,9	1-1	B-B	J-J	B-Z	Z-Z	G-F
X1T5.9	31	5,9	1-1	B-B	J-J	B-Z	Z-Z	G-F
X1T6.5	32	6,5	1-1	B-B	J-J	B-Z	Z-Z	G-F
X1T7.8	34	7,8	1-1	B-B	J-J	B-Z	Z-Z	G-F
X1T8.8	36	9,8	1-1	B-B	J-J	B-Z	Z-Z	G-F

Tavola con indicate le combinazioni delle flangiateure e flettatore standard disponibili a magazzino

Corpo (flettature e flangiateure)						
A	B	C	D	E	F	G
			Corpo Chiuso			Z

Vivoli Oleodinamica s.r.l. - Società a Socio Unico - via Leone Ginzburg 2-4 40054 Budrio (BO) Italy tel. +39 051 803689 fax +39 051 800061  
 XT113 www.vivoli.com - italiano 15/05/2008

## MULTIPLE PUMPS – SINGLE ELEMENTS

### DISPLACEMENT, PRESSURES AND SPEED

	Type	Displacement	Max Pressure	Min speed	Max Speed
XV-0P	XV-0P/0.17	0.16 cm <sup>3</sup> /giro	260 bar	700 giri/min	9000 giri/min
	XV-0P/0.25	0.24 cm <sup>3</sup> /giro	260 bar	700 giri/min	9000 giri/min
	XV-0P/0.45	0.45 cm <sup>3</sup> /giro	280 bar	700 giri/min	9000 giri/min
	XV-0P/0.57	0.56 cm <sup>3</sup> /giro	280 bar	700 giri/min	9000 giri/min
	XV-0P/0.76	0.75 cm <sup>3</sup> /giro	280 bar	700 giri/min	9000 giri/min
	XV-0P/0.98	0.92 cm <sup>3</sup> /giro	280 bar	700 giri/min	6000 giri/min
	XV-0P/1.27	1.26 cm <sup>3</sup> /giro	280 bar	700 giri/min	6000 giri/min
	XV-0P/1.52	1.48 cm <sup>3</sup> /giro	280 bar	700 giri/min	6000 giri/min
	XV-0P/2.30	2.28 cm <sup>3</sup> /giro	210 bar	700 giri/min	5000 giri/min
XV-1P	XV-1P/0.9	0.91 cm <sup>3</sup> /giro	280 bar	700 giri/min	6000 giri/min
	XV-1P/1.2	1.17 cm <sup>3</sup> /giro	290 bar	700 giri/min	6000 giri/min
	XV-1P/1.7	1.56 cm <sup>3</sup> /giro	290 bar	700 giri/min	6000 giri/min
	XV-1P/2.2	2.08 cm <sup>3</sup> /giro	290 bar	700 giri/min	6000 giri/min
	XV-1P/2.6	2.60 cm <sup>3</sup> /giro	300 bar	700 giri/min	6000 giri/min
	XV-1P/3.2	3.12 cm <sup>3</sup> /giro	300 bar	700 giri/min	6000 giri/min
	XV-1P/3.8	3.64 cm <sup>3</sup> /giro	300 bar	700 giri/min	6000 giri/min
	XV-1P/4.3	4.16 cm <sup>3</sup> /giro	300 bar	700 giri/min	6000 giri/min
	XV-1P/4.9	4.94 cm <sup>3</sup> /giro	300 bar	700 giri/min	6000 giri/min
	XV-1P/5.9	5.85 cm <sup>3</sup> /giro	300 bar	700 giri/min	5000 giri/min
	XV-1P/6.5	6.50 cm <sup>3</sup> /giro	300 bar	700 giri/min	5000 giri/min
	XV-1P/7.8	7.54 cm <sup>3</sup> /giro	260 bar	700 giri/min	5000 giri/min
XV-1P/9.8	9.88 cm <sup>3</sup> /giro	260 bar	700 giri/min	4000 giri/min	
XV-2P	XV-2P/4	4.2 cm <sup>3</sup> /giro	300 bar	700 giri/min	3500 giri/min
	XV-2P/6	6.0 cm <sup>3</sup> /giro	300 bar	700 giri/min	3500 giri/min
	XV-2P/9	8.4 cm <sup>3</sup> /giro	300 bar	700 giri/min	3500 giri/min
	XV-2P/11	10.8 cm <sup>3</sup> /giro	300 bar	700 giri/min	3500 giri/min
	XV-2P/14	14.4 cm <sup>3</sup> /giro	290 bar	700 giri/min	3500 giri/min
	XV-2P/17	17.8 cm <sup>3</sup> /giro	270 bar	700 giri/min	3500 giri/min
	XV-2P/19	20.2 cm <sup>3</sup> /giro	250 bar	700 giri/min	3000 giri/min
	XV-2P/22	22.8 cm <sup>3</sup> /giro	240 bar	700 giri/min	3000 giri/min
	XV-2P/26	26.2 cm <sup>3</sup> /giro	210 bar	700 giri/min	3000 giri/min
	XV-2P/30	30.0 cm <sup>3</sup> /giro	200 bar	700 giri/min	2500 giri/min
	XV-2P/34	34.2 cm <sup>3</sup> /giro	190 bar	700 giri/min	2500 giri/min
	XV-2P/40	39.6 cm <sup>3</sup> /giro	180 bar	700 giri/min	2000 giri/min
XV-3P	XV-3P/15	14.89 cm <sup>3</sup> /giro	320 bar	700 giri/min	3000 giri/min
	XV-3P/18	17.37 cm <sup>3</sup> /giro	320 bar	700 giri/min	3000 giri/min
	XV-3P/21	21.10 cm <sup>3</sup> /giro	300 bar	700 giri/min	3000 giri/min
	XV-3P/27	26.97 cm <sup>3</sup> /giro	270 bar	700 giri/min	3000 giri/min
	XV-3P/32	32.27 cm <sup>3</sup> /giro	270 bar	700 giri/min	3000 giri/min
	XV-3P/38	38.47 cm <sup>3</sup> /giro	270 bar	700 giri/min	2800 giri/min
	XV-3P/43	43.44 cm <sup>3</sup> /giro	250 bar	700 giri/min	2800 giri/min
	XV-3P/47	47.16 cm <sup>3</sup> /giro	250 bar	700 giri/min	2800 giri/min
	XV-3P/51	50.88 cm <sup>3</sup> /giro	250 bar	700 giri/min	2800 giri/min
	XV-3P/54	54.60 cm <sup>3</sup> /giro	250 bar	700 giri/min	2300 giri/min
	XV-3P/61	60.81 cm <sup>3</sup> /giro	220 bar	700 giri/min	2300 giri/min
	XV-3P/64	64.53 cm <sup>3</sup> /giro	220 bar	700 giri/min	2300 giri/min
XV-3P/70	70.74 cm <sup>3</sup> /giro	210 bar	700 giri/min	2300 giri/min	
XV-3P/74	74.46 cm <sup>3</sup> /giro	190 bar	700 giri/min	2300 giri/min	
XV-3P/90	86.87 cm <sup>3</sup> /giro	160 bar	700 giri/min	2300 giri/min	

## MULTIPLE PUMPS – SINGLE ELEMENTS

### General technical data

Type of fluid to be used	Mineral-based hydraulic oil HLP HV (D IN 51524)
Minimum operating viscosity	10 mm <sup>2</sup> /s
Maximum operating viscosity	100 mm <sup>2</sup> /s
Maximum admissible viscosity at start-up	1500 mm <sup>2</sup> /s
Recommended viscosity	20 mm <sup>2</sup> /s - 100 mm <sup>2</sup> /s
Ambient temperature	-20 °C - 60°C
Fluid operating temperature	-15°C - 80°C
Recommended fluid operating temperature	30°C - 50°C
For temperatures above 120°C	Request FKM seals ( Viton)
Max. inlet fluid suction pressure (IN)	0.02-0.08 bars
Max. inlet fluid pressure (IN)	0.3 - 0.5 bars (for higher pressures consult the manufacturer)
Inlet fluid filtering (IN)	30 - 60 Microns
Outlet fluid filtering (OUT)	10 - 25 Microns
Max. inlet fluid speed (IN)	0.5 - 1.5 m/s
Max. outlet fluid speed (OUT)	3.0 - 5.5m/s
Use of water-glycol (HF-C)	max n. of revolutions 1100 rpm; max pressure 10 bars

### Flow rate tables

TYPE	cm <sup>3</sup> /rev	Flow rate /min	rpm														Flow rate /min		
			700	1000	1500	2000	2500	3000	3500	4000	4500	5000	5500	6000	7000	8000		9000	
XV 0P/0.17	0,16	Flow rate /min	0,106	0,152	0,228	0,304	0,380	0,456	0,532	0,608	0,684	0,760	0,836	0,912	1,064	1,216	1,368	Flow rate /min	
XV 0P/0.25	0,24		0,160	0,228	0,342	0,456	0,570	0,684	0,798	0,912	1,026	1,140	1,254	1,368	1,596	1,824	2,052		
XV 0P/0.45	0,45		0,299	0,428	0,641	0,855	1,069	1,283	1,496	1,710	1,924	2,138	2,351	2,565	2,993	3,420	3,848		
XV 0P/0.57	0,56		0,372	0,532	0,798	1,064	1,330	1,596	1,862	2,128	2,394	2,660	2,926	3,192	3,724	4,256	4,788		
XV 0P/0.76	0,75		0,499	0,713	1,069	1,425	1,781	2,138	2,494	2,850	3,206	3,563	3,919	4,275	4,988	5,700	6,413		
XV 0P/0.98	0,92		0,612	0,874	1,311	1,748	2,185	2,622	3,059	3,496	3,933	4,370	4,807	5,244					
XV 0P/1.27	1,26		0,838	1,197	1,796	2,394	2,993	3,591	4,190	4,788	5,387	5,985	6,584	7,182					
XV 0P/1.52	1,48		0,984	1,406	2,109	2,812	3,515	4,218	4,921	5,624	6,327	7,030	7,733	8,436					
XV 0P/2.30	2,28		1,516	2,166	3,249	4,332	5,415	6,498	7,581	8,664	9,747	10,830							

TYPE	cm <sup>3</sup> /rev	Flow rate /min	rpm											Flow rate /min	
			700	1000	1500	2000	2500	3000	3500	4000	4500	5000	5500		6000
XV 1P/0.9	0,91	Flow rate /min	0,630	0,900	1,350	1,800	2,250	2,700	3,150	3,600	4,050	4,500	4,950	5,400	Flow rate /min
XV 1P/1.2	1,17		0,840	1,200	1,800	2,400	3,000	3,600	4,200	4,800	5,400	6,000	6,600	7,200	
XV 1P/1.7	1,53		1,190	1,700	2,550	3,400	4,250	5,100	5,950	6,800	7,650	8,500	9,350	10,200	
XV 1P/2.2	2,08		1,540	2,200	3,300	4,400	5,500	6,600	7,700	8,800	9,900	11,000	12,100	13,200	
XV 1P/2.6	2,6		1,820	2,600	3,900	5,200	6,500	7,800	9,100	10,400	11,700	13,000	14,300	15,600	
XV 1P/3.2	3,12		2,240	3,200	4,800	6,400	8,000	9,600	11,200	12,800	14,400	16,000	17,600	19,200	
XV 1P/3.8	3,64		2,660	3,800	5,700	7,600	9,500	11,400	13,300	15,200	17,100	19,000	20,900	22,800	
XV 1P/4.3	4,16		3,010	4,300	6,450	8,600	10,750	12,900	15,050	17,200	19,350	21,500	23,650	25,800	
XV 1P/4.9	4,94		3,430	4,900	7,350	9,800	12,250	14,700	17,150	19,600	22,050	24,500	26,950	29,400	
XV 1P/5.9	5,85		4,130	5,900	8,850	11,800	14,750	17,700	20,650	23,600	26,550	29,500			
XV 1P/6.5	6,5		4,550	6,500	9,750	13,000	16,250	19,500	22,750	26,000	29,250	32,500			
XV 1P/7.8	7,54		5,460	7,800	11,700	15,600	19,500	23,400	27,300	31,200	35,100	39,000			
XV 1P/9.8	9,88	6,860	9,800	14,700	19,600	24,500	29,400	34,300	39,200						

## MULTIPLE PUMPS – SINGLE ELEMENTS

TYPE	cm3/rev	rpm							
		700	1000	1500	2000	2500	3000	3500	
XV 2P/4	4,2	2,800	4,000	6,000	8,000	10,000	12,000	14,000	
XV 2P/6	6	4,200	6,000	9,000	12,000	15,000	18,000	21,000	
XV 2P/9	8,4	6,300	9,000	13,500	18,000	22,500	27,000	31,500	
XV 2P/11	10,8	7,700	11,000	16,500	22,000	27,500	33,000	38,500	
XV 2P/14	14,4	9,800	14,000	21,000	28,000	35,000	42,000	29,000	
XV 2P/17	16,8	11,900	17,000	25,500	34,000	42,500	51,000	59,500	
XV 2P/19	19,2	13,300	19,000	28,500	38,000	47,500	57,000		
XV 2P/22	22,8	15,400	22,000	33,000	44,000	55,000	66,000		
XV 2P/26	26,2	18,200	26,000	39,000	52,000	65,000	78,000		
XV 2P/30	30	21,000	30,000	45,000	60,000	75,000			
XV 2P/34	34,2	23,800	34,000	51,000	68,000	85,000			
XV 2P/40	39,6	28,000	40,000	60,000	80,000				

TYPE	cm3/rev	rpm						
		700	1000	1500	2000	2300	2500	3000
XV 3P/15	14,89	9,90	14,15	21,22	28,29	32,54	35,37	42,44
XV 3P/18	17,37	11,55	16,51	24,76	33,01	37,96	41,26	49,52
XV 3P/21	21,10	14,03	20,04	30,06	40,08	46,10	50,11	60,13
XV 3P/27	26,97	17,94	25,61	38,43	51,24	58,93	64,05	76,86
XV 3P/32	32,27	21,46	30,65	45,98	61,31	70,50	76,63	91,96
XV 3P/38	38,47	25,98	36,55	54,82	73,09	84,06	91,37	
XV 3P/43	43,44	28,88	41,26	61,89	82,53	94,91	103,16	
XV 3P/47	47,16	31,59	44,80	67,20	89,60	103,04	112,00	
XV 3P/51	50,60	33,84	48,34	72,51	96,67	111,17		
XV 3P/54	54,60	36,31	51,87	77,81	103,75	119,31		
XV 3P/61	60,81	40,44	57,77	86,65	115,54	132,87		
XV 3P/64	64,53	42,91	61,31	91,96	122,61	141,00		
XV 3P/70	70,74	47,04	67,20	100,80	134,40	154,56		
XV 3P/74	74,46	49,52	70,74	106,11	141,47	162,70		
XV 3P/90	86,87	57,77	82,53	123,79	165,05	189,81		

## MULTIPLE PUMPS – SINGLE ELEMENTS

### XV-0P CHARACTERISTIC FLOW RATE CURVES

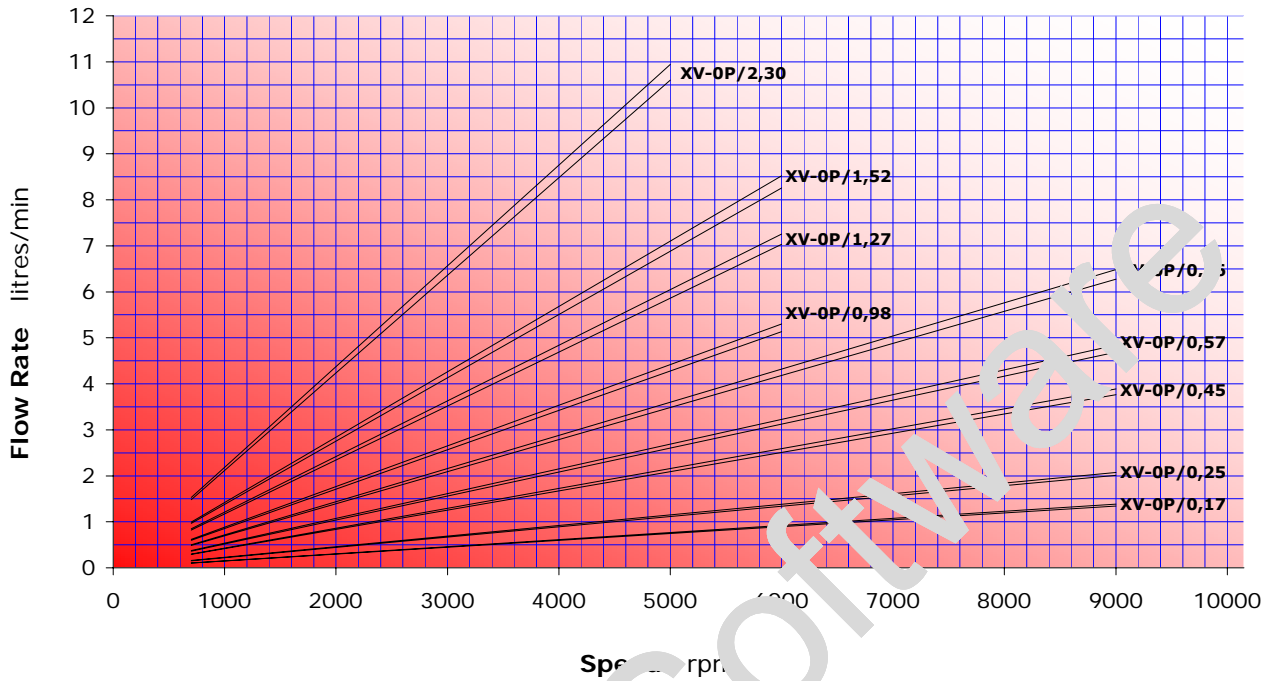

### XV-0P MOTOR TORQUE

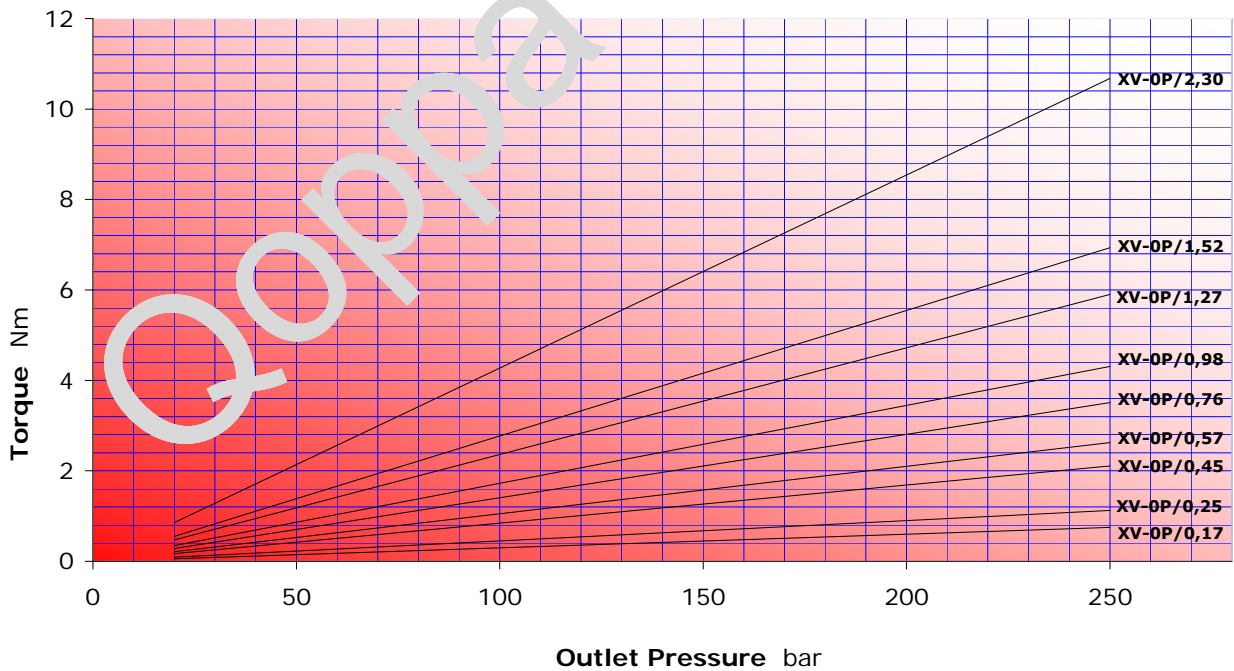

## MULTIPLE PUMPS – SINGLE ELEMENTS

### XV-1P CHARACTERISTIC FLOW RATE CURVES

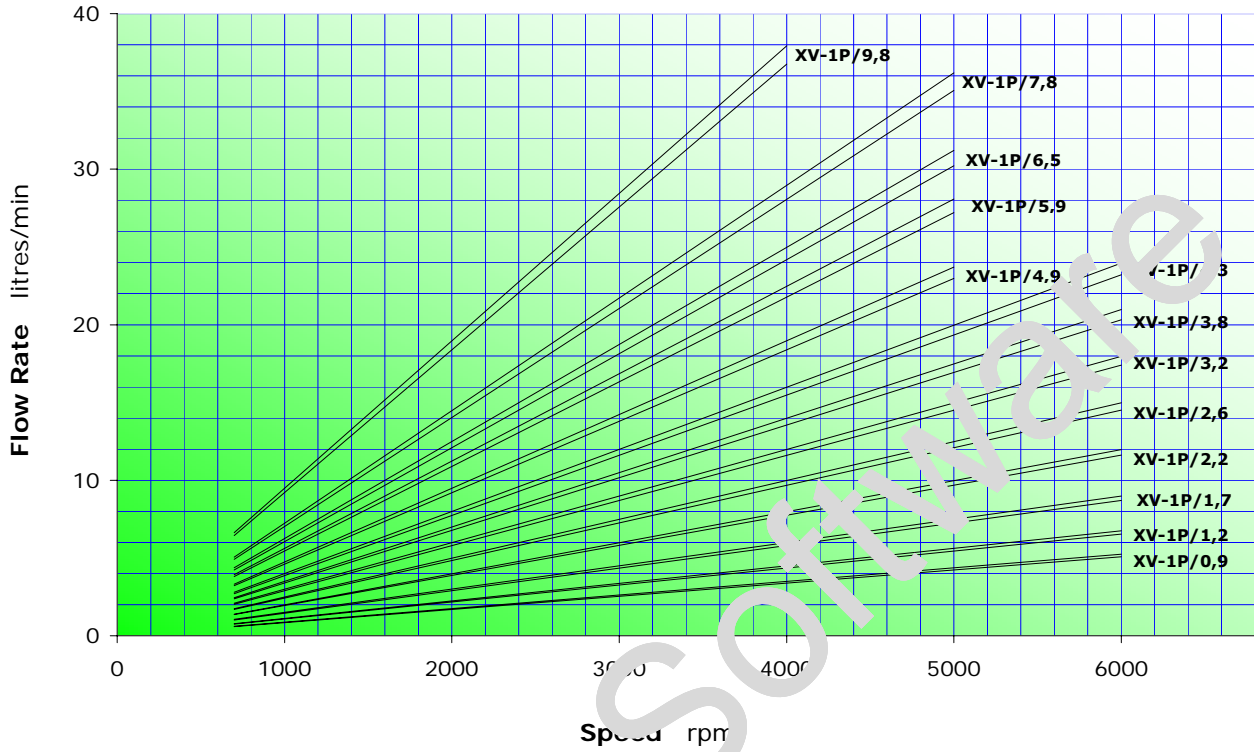

### XV-1P MOTOR TORQUE

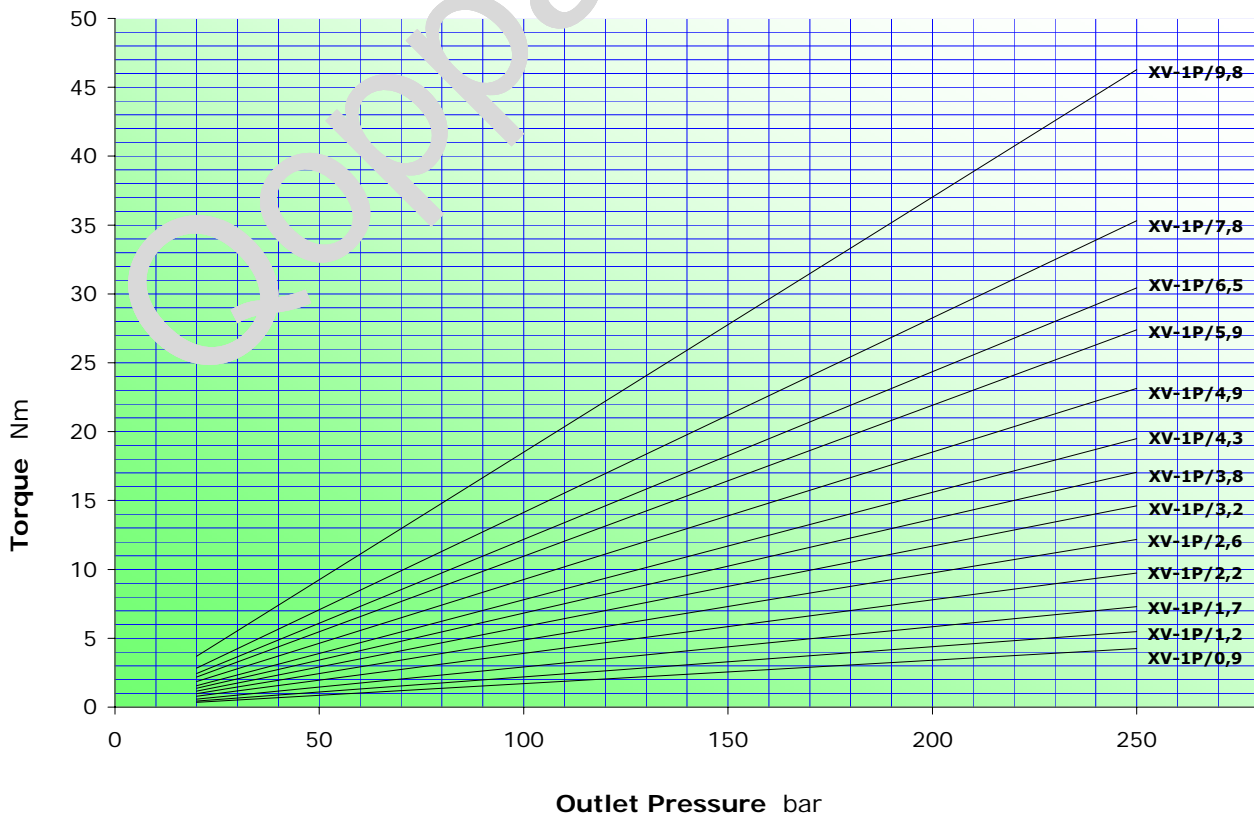

## MULTIPLE PUMPS – SINGLE ELEMENTS

### XV-2P CHARACTERISTIC FLOW RATE CURVES

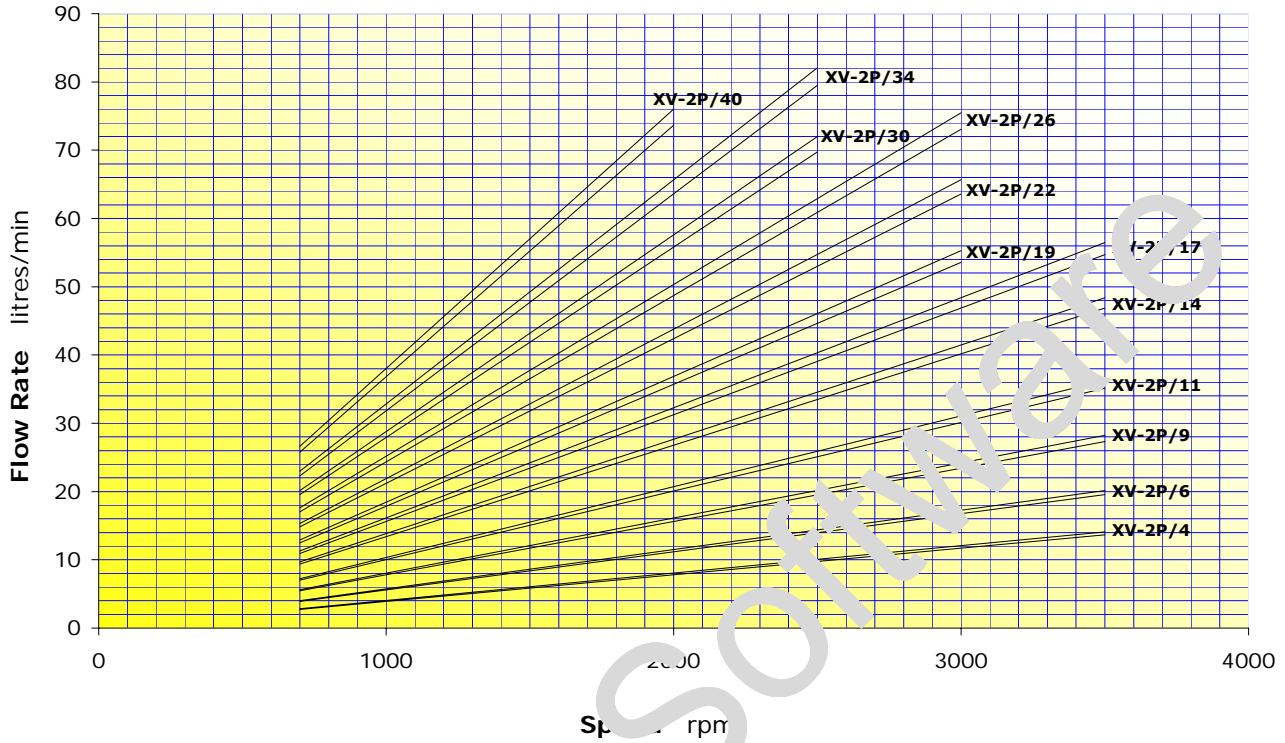

### XV-2P MOTOR TORQUE

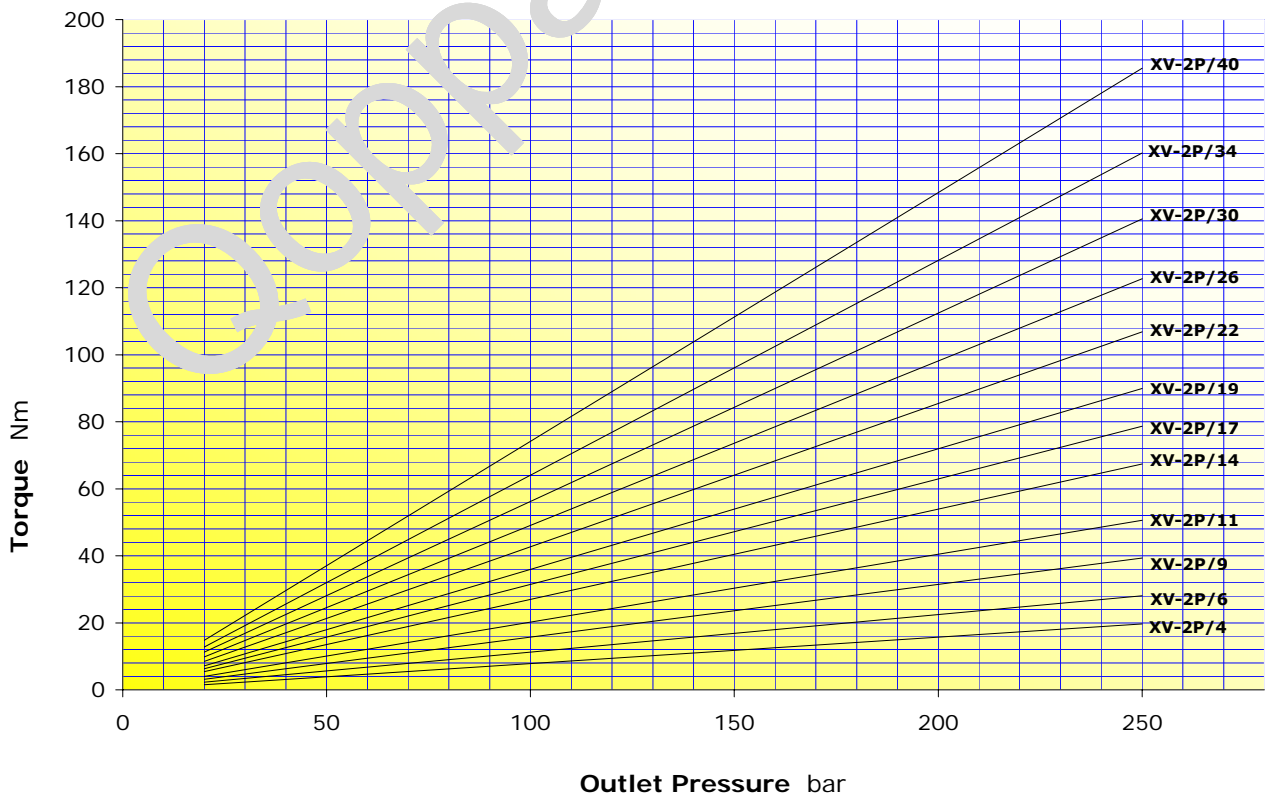



## MULTIPLE PUMPS – SINGLE ELEMENTS

### XV-3P CHARACTERISTIC FLOW RATE CURVES

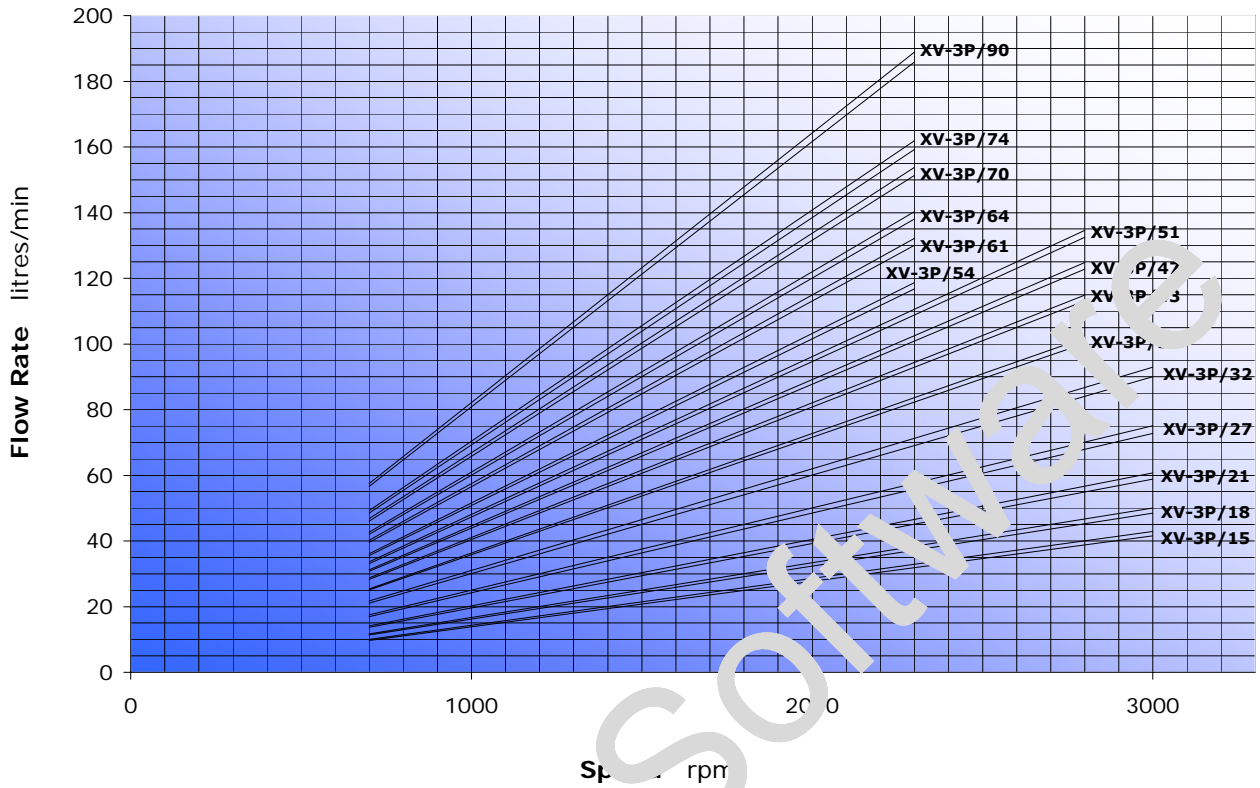

### XV-3P MOTOR TORQUE

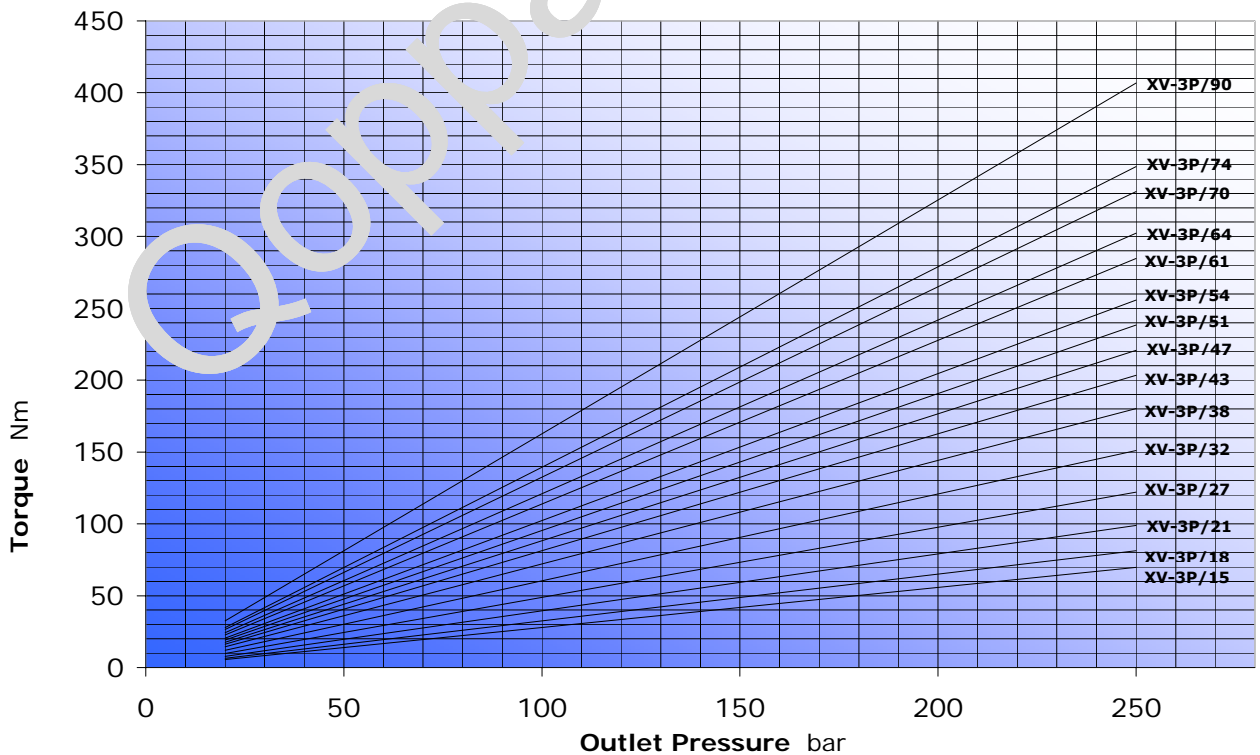

**MULTIPLE PUMPS – SINGLE ELEMENTS****Constructive features**

<b>PART</b>	<b>MATERIAL</b>	<b>MECHANICAL FEATURES</b>
<b>PUMP BODY</b>	Extruded alloy Series 7000, heat treated and anodised	$R_p = 345 \text{ N/mm}^2$ (Yield strength) $R_m = 382 \text{ N/mm}^2$ (Breaking strength)
<b>FLANGE AND COVER</b>	Die-cast aluminium alloy with excellent mechanical features, heat treated and anodised	$R_p = 310\div 350 \text{ N/mm}^2$ (Yield strength) $R_m = 350\div 400 \text{ N/mm}^2$ (Breaking strength)
<b>GEAR BUSH BEARINGS</b>	Special heat-treated tin alloy with excellent mechanical features and high anti-friction capacity. Self-lubricating bushes DU	$R_p = 350 \text{ N/mm}^2$ (Yield strength) $R_m = 390 \text{ N/mm}^2$ (Breaking strength)
<b>GEARS</b>	Steel UNI 7846	$R_p = 980 \text{ N/mm}^2$ (Yield strength) $R_m = 1270\div 1570 \text{ N/mm}^2$ (Breaking strength)
<b>SEALS</b>	A 727 Standard Acrylonitrile F 975 Viton FKM	70 Shore, thermal resistance 120°C 80 Shore, thermal resistance 200°C
<b>BACK-UP RINGS</b>	Virgin PTFE Tecnil Q3	

## MULTIPLE PUMPS – SINGLE ELEMENTS

### LINKING KIT

To assemble multiple pump starting from single element (driving, intermediate and final pump), dedicated linking kit are required. They can be chosen starting from the dimensional group of the elements to be assembled. Currently no linking kit are available for separated stage or common inlet solutions.

In the following pages you can find the available Kit, their content and how they should be applied.

#### Accoppiamento - Linking (Cod.: 8KITR001)

**OP + OP**

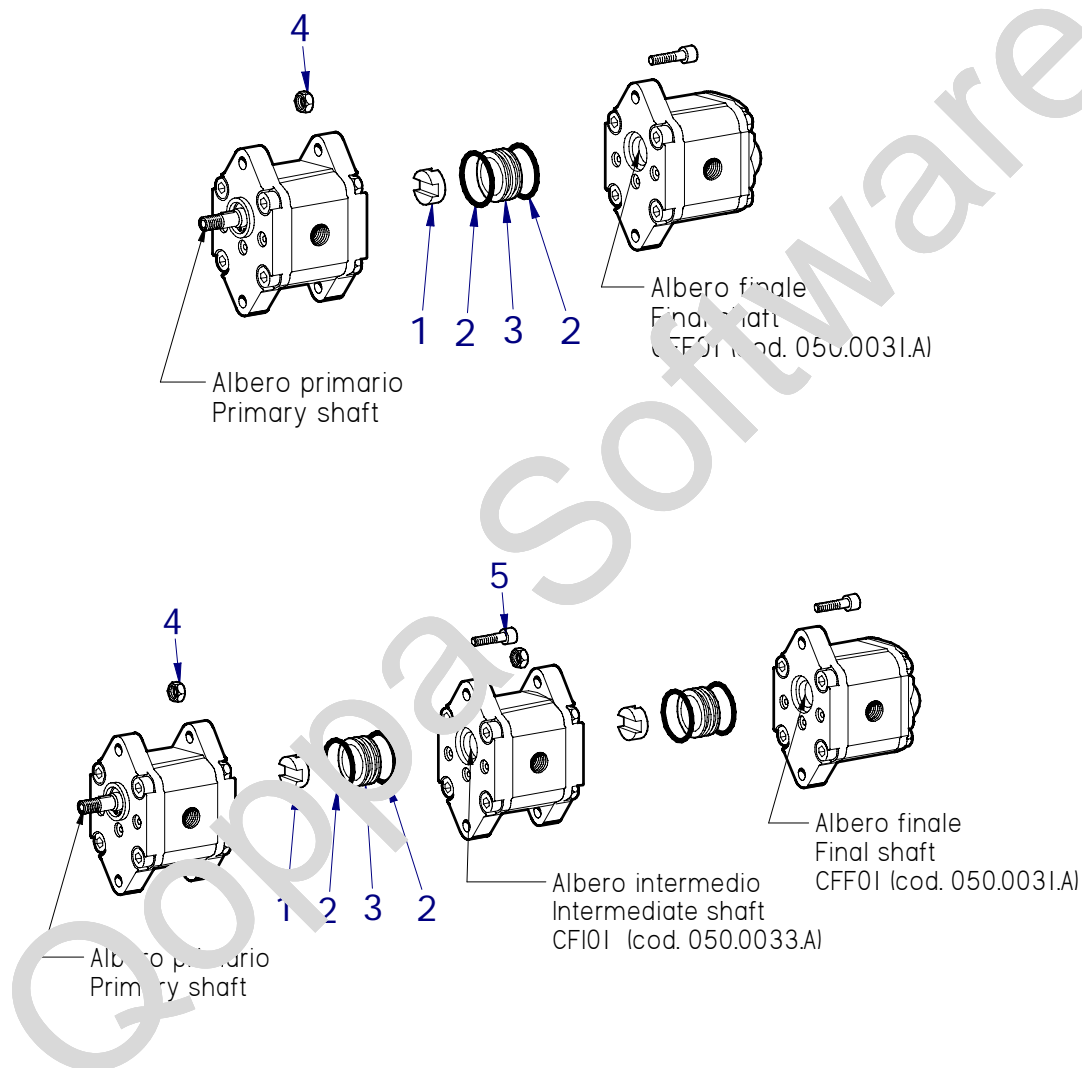

KIT ACCOPPIAMENTO WV OP+OP LINKING KIT WV OP+OP				Cod.: 8KITR001
Pos.	Code	Qt. à	Descrizione	Description
1	050.0070.A	1	Giunto a croce	Slider coupling
2	640.0025.A	2	OR 18,77 x 1,78	OR 18,77 x 1,78
3	050.0106.A	1	Anello di centraggio	Centering ring
4	540.0030.A	2	Dado M6 H=6	Nut M6 H=6
5	521.0006.AL025	2	Vite TCCE M6 x 25	Screw TCCE M6 x 25

**MULTIPLE PUMPS – SINGLE ELEMENTS**

Accoppiamento– Linking (Cod.: 8KITR002)

**1P + 1P**

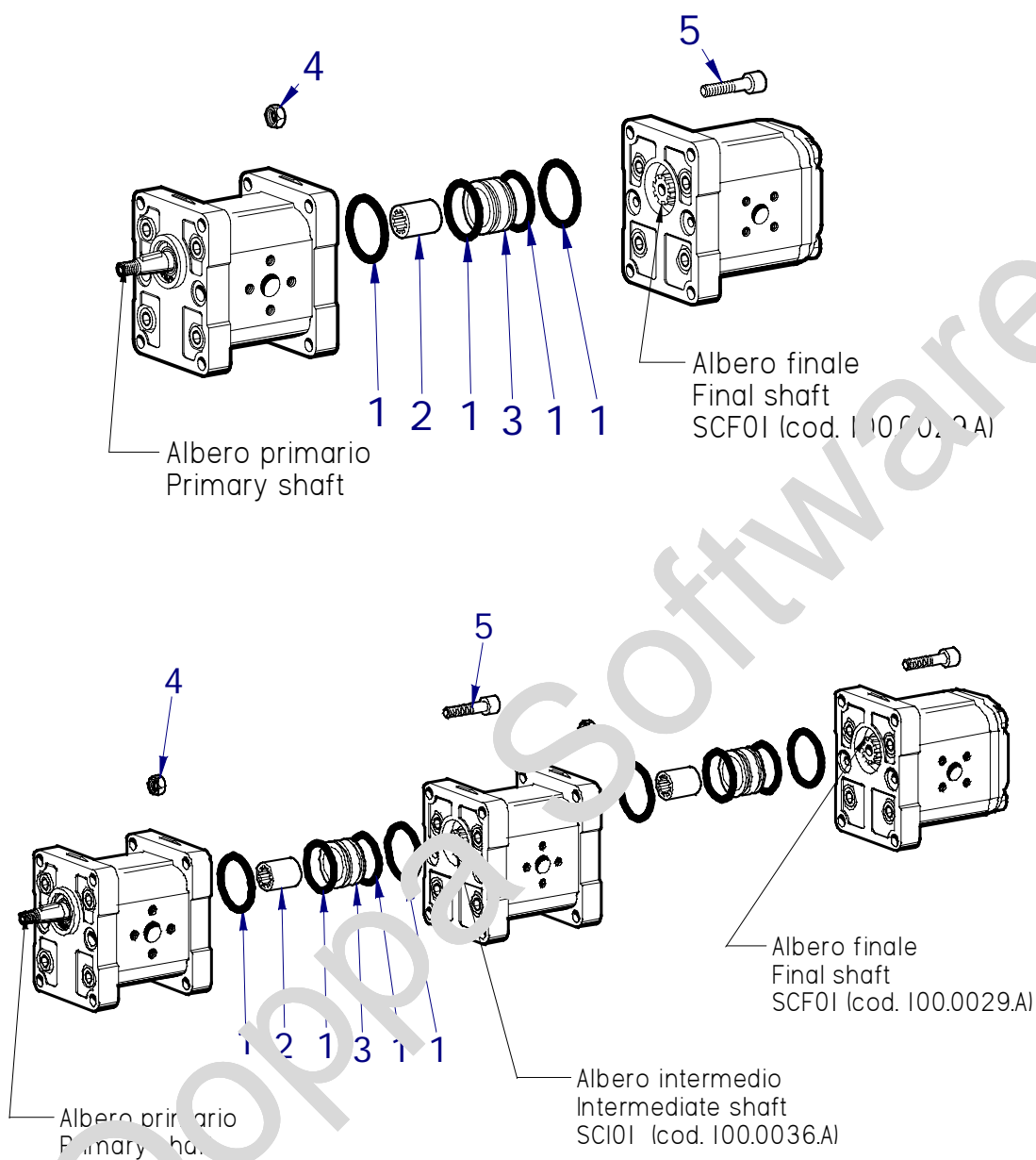

KIT ACCOPPIAMENTO XV 1P+1P LINKING KIT XV 1P+1P				Cod.: 8KITR002
Pos.	Code	Qt.à	Descrizione	Description
1	640.0030.A	4	OR 21.95 x1.78	OR 21.95 x1.78
2	100.0058.A	1	Manicotto scanalato	Grooved sleeve
3	100.0082.A	1	Anello di centraggio	Centering ring
4	540.0030.A	4	Dado M6 H=6	Nut M6 H=6
5	521.0006.AL035	4	Vite TCCE M6 x 35	Screw TCCE M6 x 35

## MULTIPLE PUMPS – SINGLE ELEMENTS

Accoppiamento– Linking (Cod.: 8KITR003 - 8KITR007) **1P + 0P**

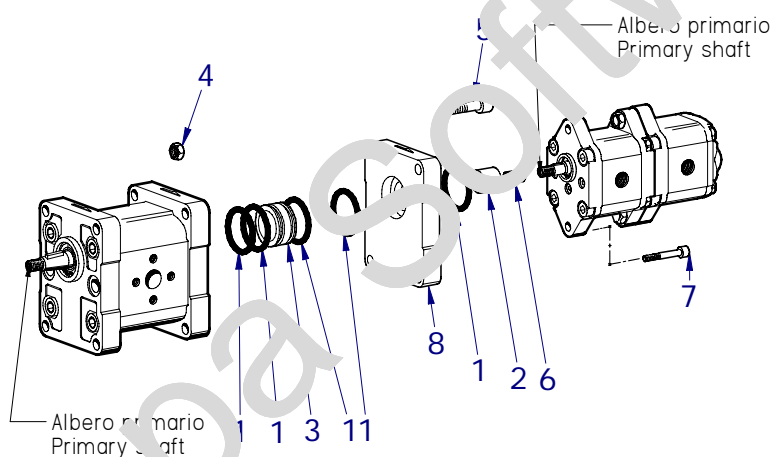
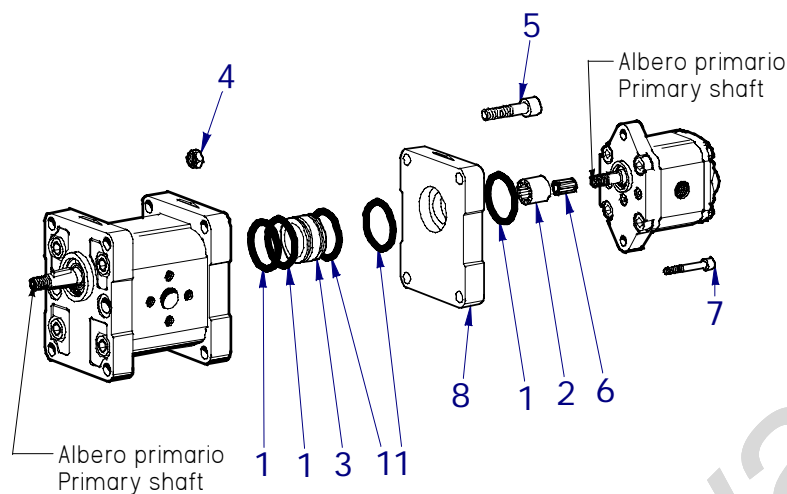

KIT ACCOPPIAMENTO XV 1P+0P LINKING KIT XV 1P+0P				Cod.: 8KITR003	
Pos.	Code	Qt.à	Descrizione	Description	
1	640.0030.A	5	OR 21.95x1.78	OR 21.95x1.78	
2	100.0021.A	1	Manicotto scanalato	Grooved sleeve	
3	100.0082.A	1	Anello di centraggio	Centering ring	
4	540.0030.A	4	Dado M6 H=6	Nut M6 H=6	
5	521.0006.AL035	4	Vite TCCE M6 x 35	Screw TCCE M6 x 35	
6	050.0040.A	1	Manicotto scanalato	Grooved sleeve	
7	521.0006.AL025	2	Vite TCCE M6 x 25	Screw TCCE M6 x 25	

KIT ACCOPPIAMENTO XV 1P+0P con flangia di supporto LINKING KIT XV 1P+0P with mounting flange				Cod.: 8KITR007	
Pos.	Code	Qt.à	Descrizione	Description	
	8KITR003	1	KIT 1P+0P	KIT 1P+0P	
8	100.0044.A	1	flangia di supporto 1P+0P	1P+0P mounting flange	

## MULTIPLE PUMPS – SINGLE ELEMENTS

Accoppiamento– Linking Cod.: (8KITR004)

**2P + 2P**

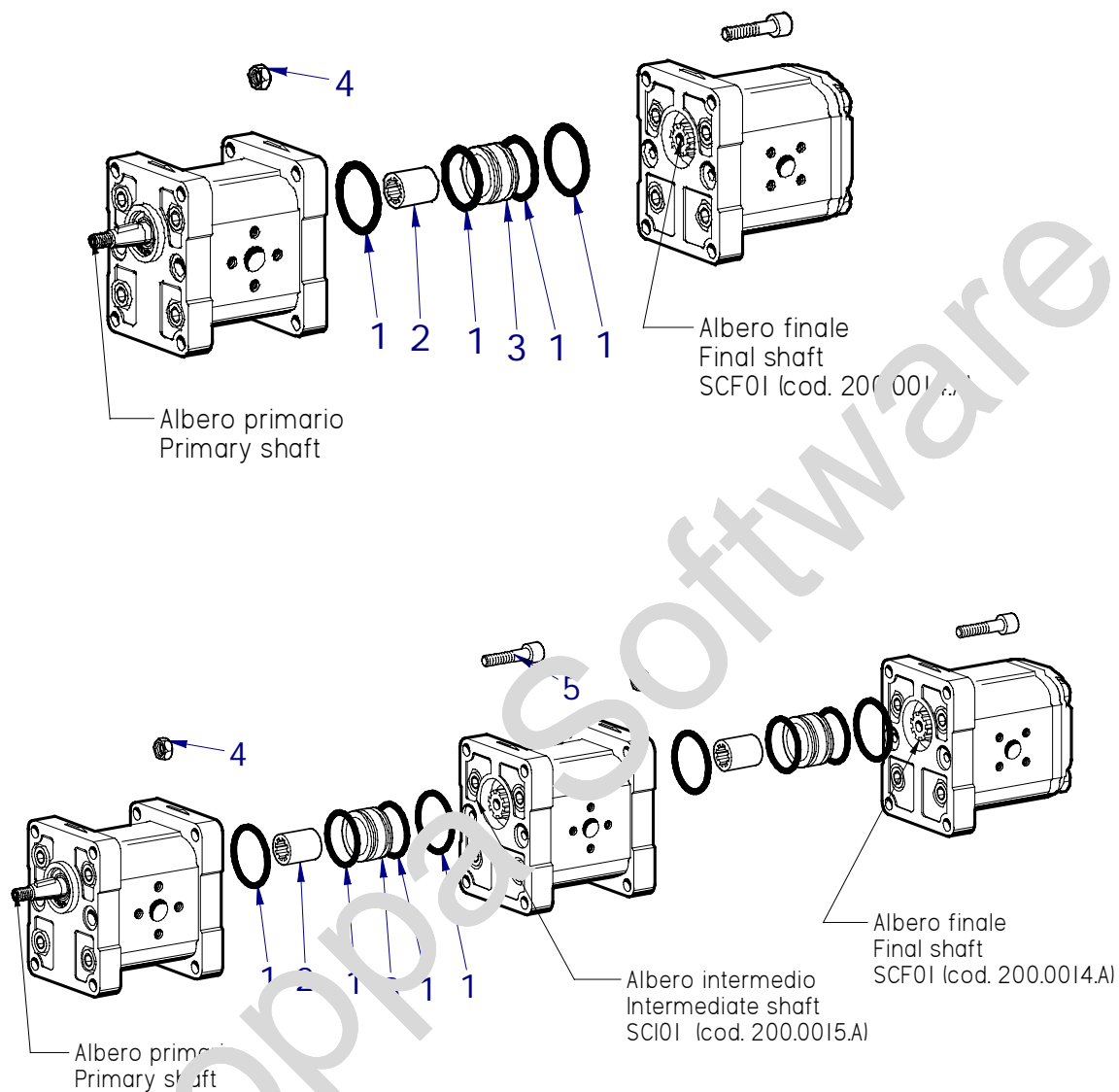

KIT ACCOPPIAMENTO XV 2P + 2P LINKING KIT XV 2P + 2P				Cod.: 8KITR004
Pos.	Code	Qt.à	Descrizione	Description
1	640.0045.A	4	OR 33.05x1.78	OR 33.05x1.78
2	200.0019.B	1	Manicotto scanalato	Grooved sleeve
3	200.0065.A	1	Anello di centraggio	Centering ring
4	540.0045.A	4	Dado M8 H=8	Nut M8 H=8
5	521.0008.AL35	4	Vite TCCE M8 x 35	Screw TCCE M8 x 35

## MULTIPLE PUMPS – SINGLE ELEMENTS

Accoppiamento – Linking (Cod.: 8KITR005)

**2P + 1P**

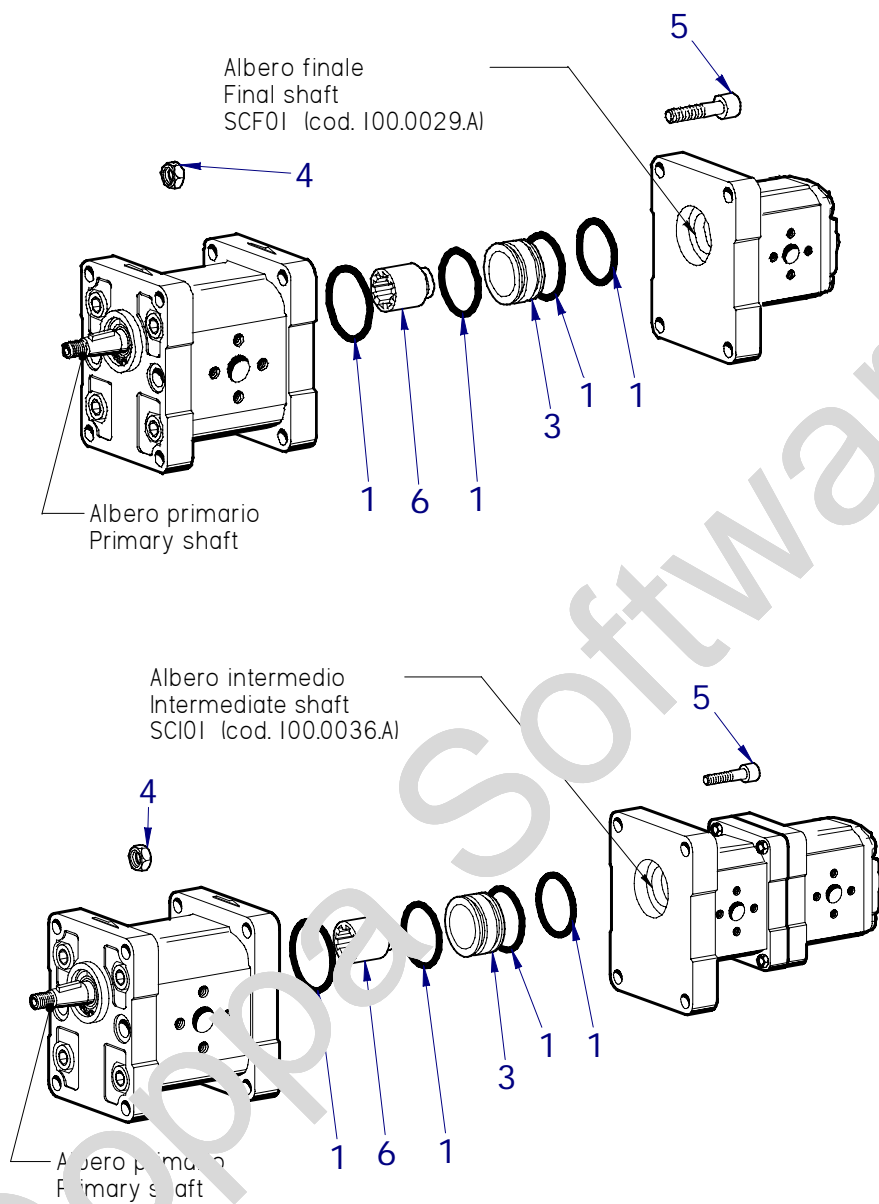

KIT ACCOPIAMENTO XV 2P + 1P LINKING KIT XV 2P + 1P				Cod.: 8KITR005
Pos.	Code	Qt.à	Descrizione	Description
1	640.0045.A	4	OR 33.05x1.78	OR 33.05x1.78
3	200.0065.A	1	Anello di centraggio	Centering ring
4	540.0045.A	4	Dado M8 H=8	Nut M8 H=8
5	521.0008.AL035	4	Vite TCCE M8 x 35	Screw TCCE M8 x 35
6	200.0046.A	1	Manicotto scanalato	Grooved sleeve

## MULTIPLE PUMPS – SINGLE ELEMENTS

Accoppiamento – Linking (Cod.: 8KITR006 - 8KITR008) **2P + 0P**

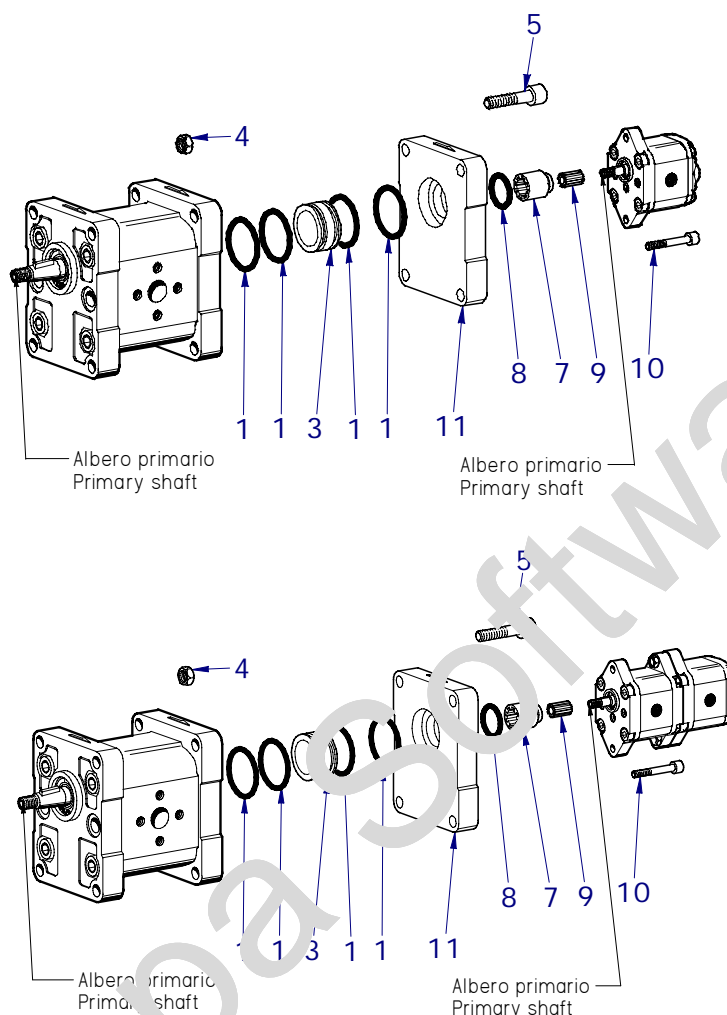

KIT ACCOPPIAMENTO XV 2P + 0P LINKING KIT XV 2P + 0P				Cod.: 8KITR006
Pos.	Code	Qt.à	Descrizione	Description
1	640.0045.A	4	OR 33.05x1.78	OR 33.05x1.78
3	200.0065.A	1	Anello di centraggio	Centering ring
4	640.0045.A	4	Dado M8 H=8	Nut M8 H=8
5	521.0008.AL040	4	Vite TCCE M8 x 40	Screw TCCE M8 x 40
7	200.0162.A	1	Manicotto scanalato	Grooved sleeve
8	640.0030.A	1	OR 21.95 x 1.78	OR 21.95 x 1.78
9	050.0040.A	1	Manicotto scanalato	Grooved sleeve
10	521.0006.AL025	2	Vite TCCE M6 x 25	Screw TCCE M6 x 25

KIT ACCOPPIAMENTO XV 2P+0P con flangia di supporto LINKING KIT XV 2P+ 0P with mounting flange				Cod.: 8KITR008
Pos.	Code	Qt.à	Descrizione	Description
	8KITR006	1	KIT 2P+0P	KIT 2P+0P
11	200.0170.A	1	flangia di supporto 2P+0P	2P+0P mounting flange



## MULTIPLE PUMPS – SINGLE ELEMENTS

### Accoppiamento – Linking (Cod: 8KITR013) **3P + 3P**

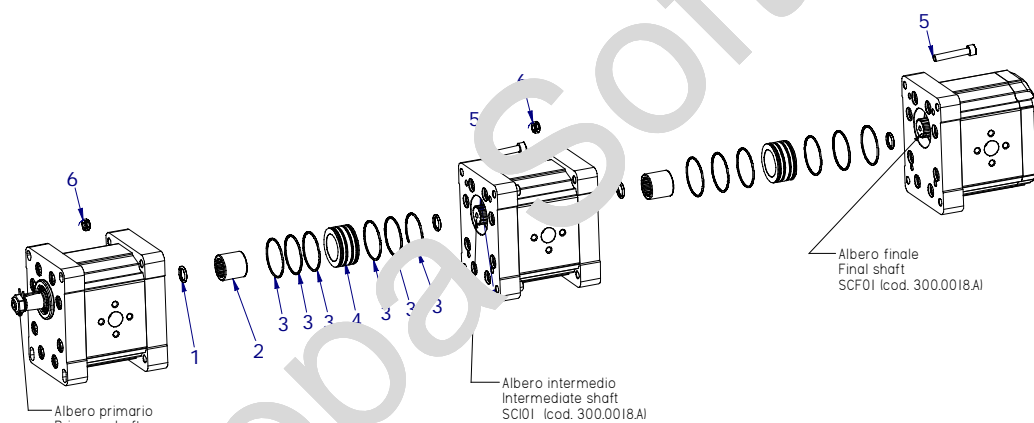
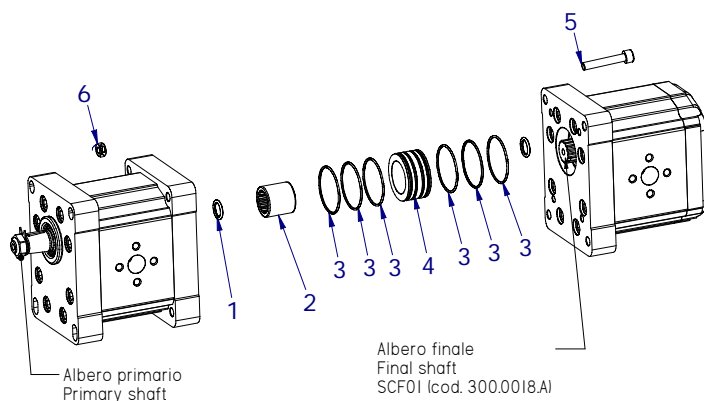

KIT ACCOPPIAMENTO XV 3P + 3P LINKING KIT XV 3P + 3P				Cod.: 8KITR013
Pos.	Code	Qt.à	Descrizione	Description
1	650.0015.A	2	OR 18.72 x 2.62	OR 18.72 x 2.62
2	300.0019.A	1	Manicotto scanalato	Grooved sleeve
3	640.0085.A	6	OR 47.35 x 1.78	OR 47.35 x 1.78
4	300.0012.A	1	Anello di centraggio	Centering ring
5	521.0008.AL055	4	Vite TCCE M8 x 55	Screw TCCE M8 x 55
6	540.0045.A	4	Dado M8 H=8	Nut M8 H=8

## MULTIPLE PUMPS – SINGLE ELEMENTS

Accoppiamento– Linking (Cod.: 8KITR012) **3P** + **2P**

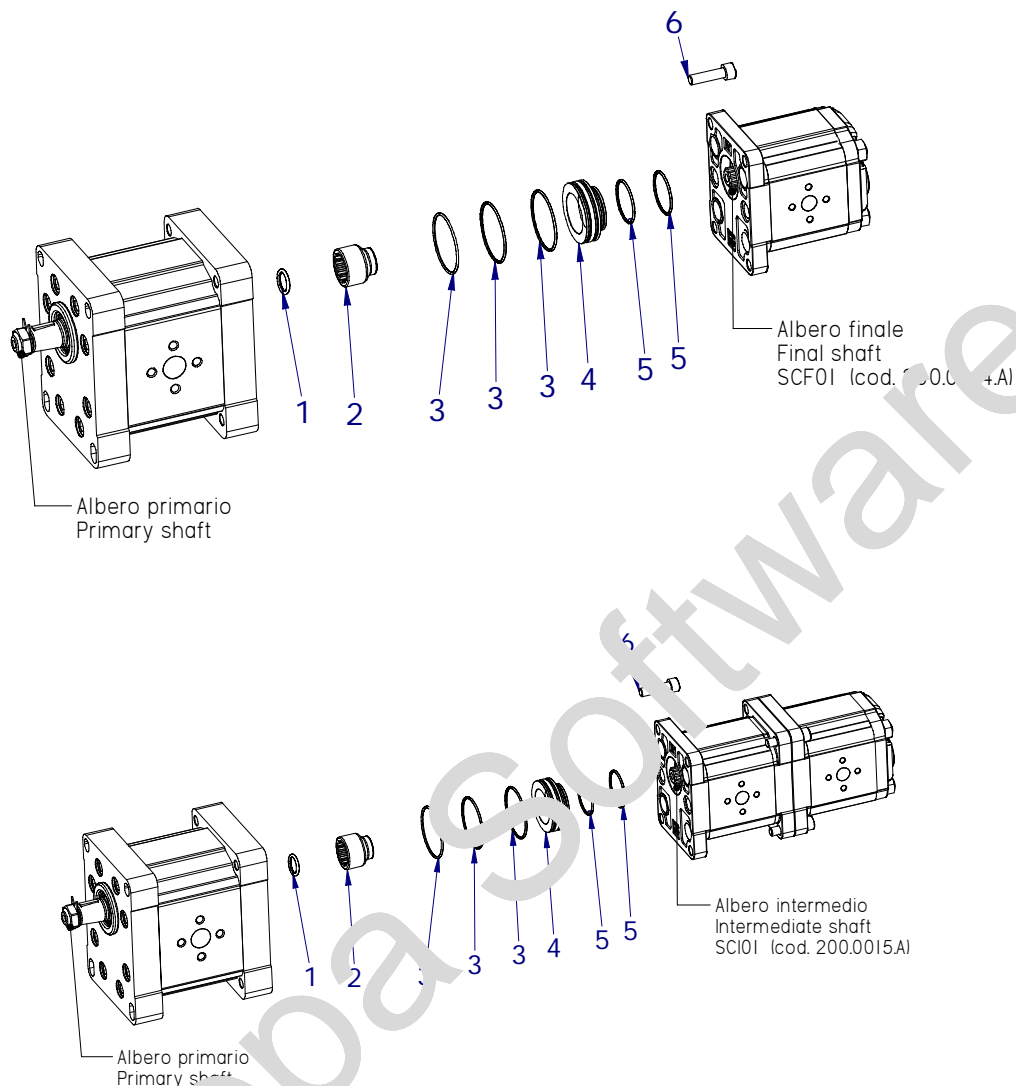

KIT ACCOPIAMENTO XV 3P + 2P LINKING KIT XV 3P + 2P				Cod.: 8KITR012
Pos.	Code	Qt.à	Descrizione	Description
1	650.0015.A	1	OR 18.72 x 2.62	OR 18.72 x 2.62
2	300.0021.A	1	Manicotto scanalato	Grooved sleeve
3	640.0085.A	3	OR 47.35 x 1.78	OR 47.35 x 1.78
4	300.0020.A	1	Anello di centraggio	Centering ring
5	640.0045.A	2	OR 33.05 x 1.78	OR 33.05 x 1.78
6	521.0008.AL25	4	Vite TCCE M8 x 25	Screw TCCE M8 x 25

## MULTIPLE PUMPS – SINGLE ELEMENTS

Accoppiamento – Linking (Cod.: 8KITR011)

**3P + 1P**

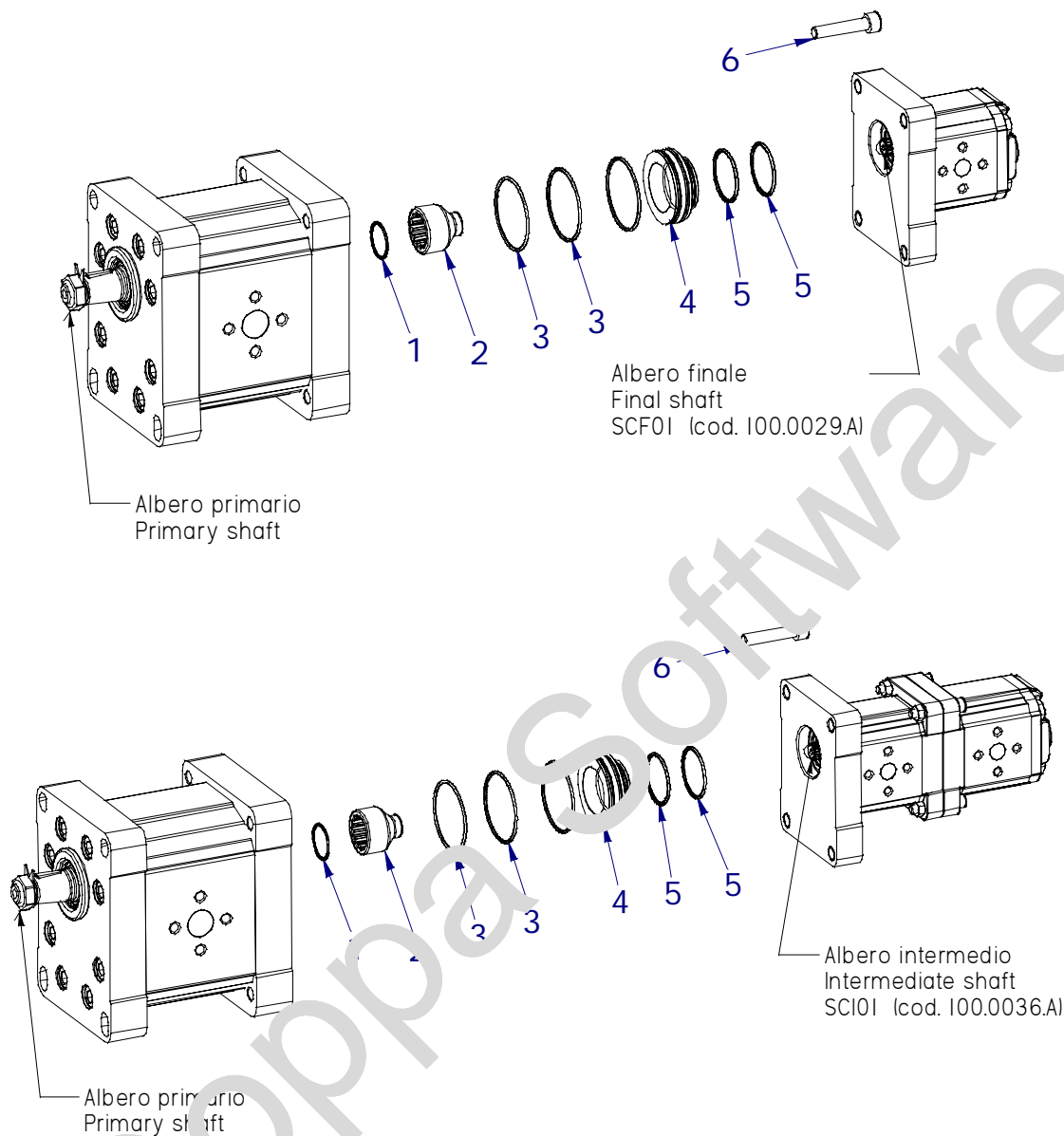

KIT ACCOPPIAMENTO XV 3P + 1P LINKING KIT XV 3P + 1P				Cod.: 8KITR011
Pos.	Code	Qt.à	Descrizione	Description
1	650.0015.A	2	OR 18.72 x 2.62	OR 18.72 x 2.62
2	300.0022.A	1	Manicotto scanalato	Grooved sleeve
3	640.0085.A	3	OR 47.35 x 1.78	OR 47.35 x 1.78
4	300.0020.A	1	Anello di centraggio	Centering ring
5	640.0045.A	2	OR 33.05 x 1.78	OR 33.05 x 1.78
6	521.0008.AL35	4	Vite TCCE M8 x 35	Screw TCCE M8 x 35

## MULTIPLE PUMPS – SINGLE ELEMENTS

Accoppiamento– Linking (Cod.: 8KITR009- 8KITR015) **3P** + **0P**

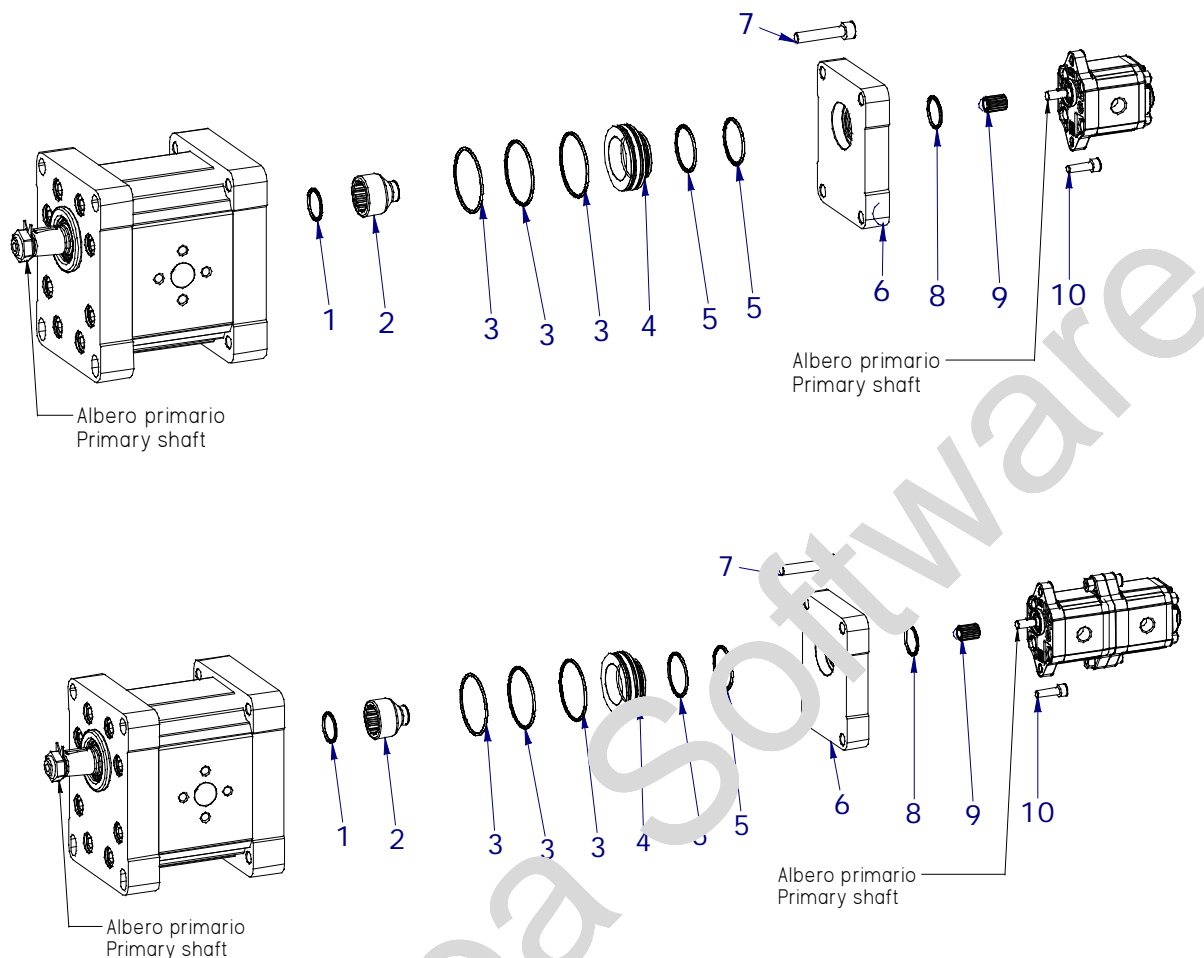

KIT ACCOPPIAMENTO XV 3P + 0P LINKING KIT XV 3P + 0P				Cod.: 8KITR009
Pos.	Code	Qt.à	Descrizione	Description
1	650.0015.A	2	OR 18.72 x 2.62	OR 18.72 x 2.62
2	300.0022.A	1	Manicotto scanalato	Grooved sleeve
3	600.0005.A	3	OR 47.35 x 1.78	OR 47.35 x 1.78
4	300.0020.A	1	Anello di centraggio	Centering ring
5	600.0045.A	2	OR 33.05 x 1.78	OR 33.05 x 1.78
7	521.0008.AL35	4	Vite TCCE M8 x 35	Screw TCCE M8 x 35
8	640.0030.A	1	OR 21.95 x 1.78	OR 21.95 x 1.78
9	050.0040.A	1	Manicotto scanalato	Grooved sleeve
10	521.0006.AL25	2	Vite TCCE M6 x 25	Screw TCCE M6 x 25

KIT ACCOPPIAMENTO XV3P+0P con flangia di supporto LINKING KIT XV 3P+ 0P with mounting flange				Cod.: 8KITR015
Pos.	Code	Qt.à	Descrizione	Description
	8KITR009	1	KIT 3P+0P	KIT 3P+0P
6	200.0170.A	1	flangia di supporto 2P+0P	2P+0P mounting flange